

X8i

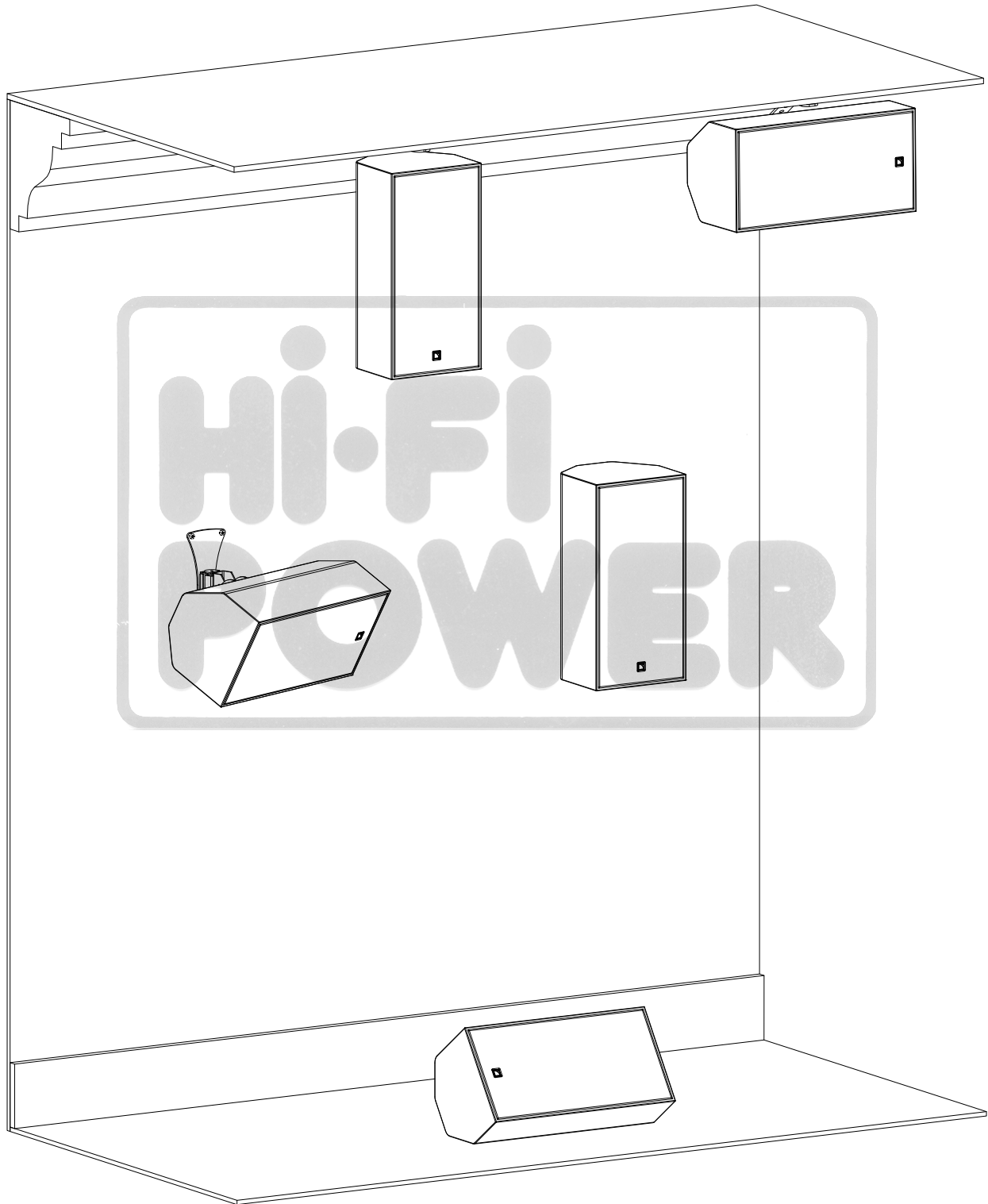

owner's manual (EN)

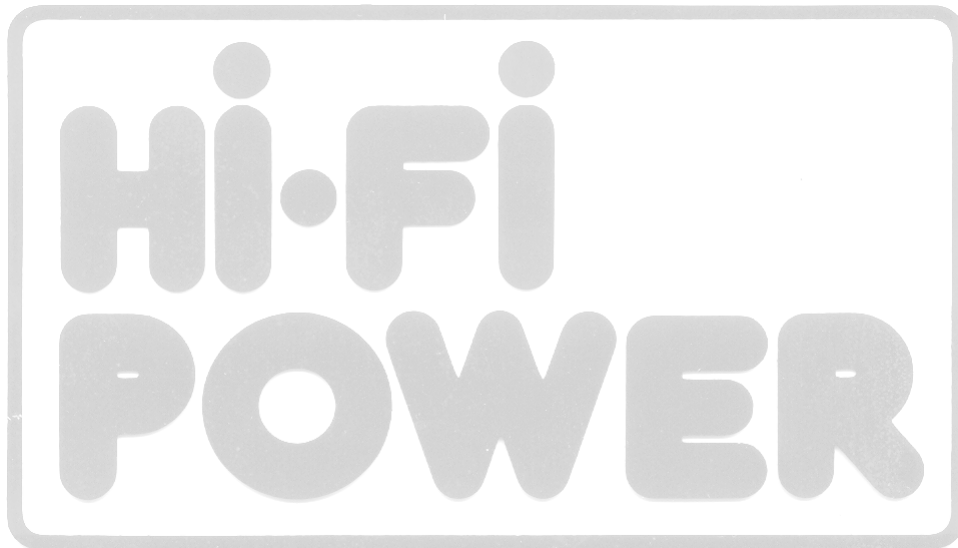



Document reference: X8i owner's manual (EN) version 2.0

Distribution date: August 29, 2024

© 2024 L-Acoustics. All rights reserved.

No part of this publication may be reproduced or transmitted in any form or by any means without the express written consent of the publisher.

Contents

Safety.....	6
Instructions.....	6
Introduction.....	8
X8i.....	8
How to use this manual.....	9
Revision history.....	10
System components.....	11
System component illustrations.....	12
Electro-acoustical description.....	14
Directivity.....	14
Preset description.....	15
Connectors.....	16
SPCON terminal block to speakON adapter.....	17
Rigging system description.....	18
X8i.....	18
Elements for wall-mounting.....	20
TILT-SUPPORT.....	20
X8i-onCW.....	21
WALL.....	22
WALLx2.....	23
Elements for ceiling-mounting or truss-mounting.....	24
VBAR.....	24
X8i-HBAR.....	26
CEILING-PENDANT.....	27
Elements for site or azimuth angle adjustment.....	28
TILT5 / TILT15 / TILT40.....	28
TILT.....	30
PAN.....	32
PANx2.....	33
Elements for ground-mounting.....	34
GROUND / GROUND35 / GROUND55.....	34
Elements for pole-mounting.....	35
POLE.....	35

Mechanical safety.....	36
Loudspeaker configurations.....	38
X8i point source.....	38
X8i point source with low-frequency element.....	38
X8i with SB10i(r).....	39
X8i with Syva Sub.....	41
X8i with KS21(i).....	42
X8i stage monitor.....	44
Low-latency preset.....	44
Paired X8i monitors with LFC.....	44
Rigging procedures.....	45
X8i mechanical configurations overview.....	45
Wall-mounting.....	48
Vertically.....	48
Horizontally.....	90
Ceiling-mounting or truss-mounting.....	129
Vertically.....	130
Horizontally.....	147
Downward-facing.....	155
Ground-mounting.....	162
Ground-mounting X8i horizontally with GROUND / GROUND55 / GROUND35.....	162
Pole-mounting.....	167
Pole-mounting X8i with POLE.....	167
Connection to LA amplified controllers.....	169
Cabling schemes for X8i.....	170
Cabling X8i.....	171
Cabling.....	172
Cabling with SPCON.....	175
Corrective maintenance.....	178
Introduction.....	178
Exploded views.....	179
Disassembly and Reassembly procedures.....	180
D/R - Grill.....	180
D/R - Coaxial loudspeaker.....	181
D/R - Diaphragm.....	182
Acoustical check.....	185
Specifications.....	189
X8i.....	189

X8i-onCW.....	191
WALL.....	192
PAN.....	193
WALLx2.....	194
PANx2.....	195
TILT.....	196
TILT5.....	197
TILT15.....	198
TILT40.....	199
GROUND.....	200
GROUND55.....	201
GROUND35.....	202
TILT-SUPPORT.....	203
X8i-HBAR.....	204
VBAR.....	205
CEILING-PENDANT.....	206
POLE.....	207
SPCON.....	208
APPENDIX A: Specifications for screws and anchors.....	209
APPENDIX B: Recommendation for speaker cables.....	210

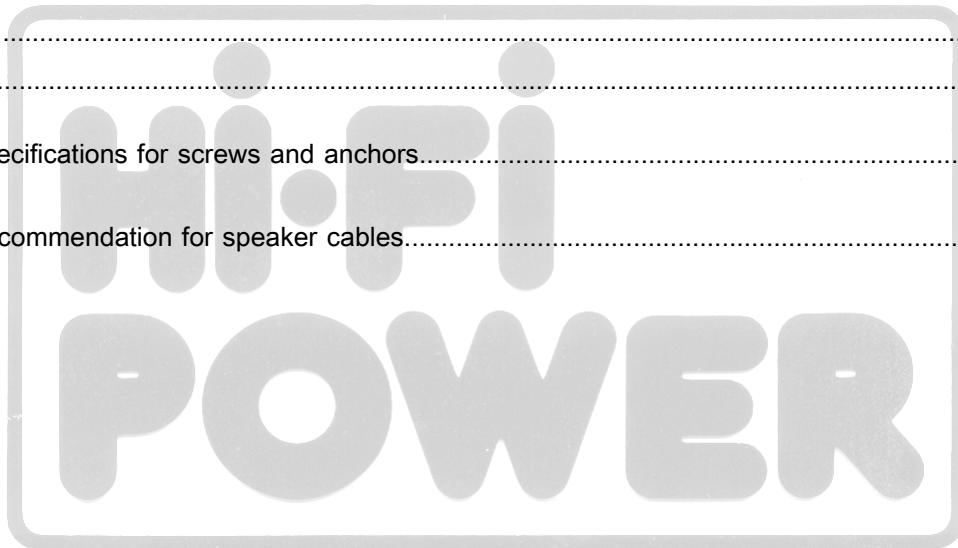

Safety

Instructions

- ! Inspect the system before any deployment.**
Perform safety related checks and inspections before any deployment.
- Perform preventive maintenance at least once a year.**
Refer to the preventive maintenance section for a list of actions and their periodicity.
Insufficient upkeep of the product can void the warranty.
- If any safety issue is detected during inspection, do not use the product before performing corrective maintenance.**
Check for issues. A rigging system part or fastener is missing or loose. A rigging system part exhibits: bends, breaks, broken parts, corrosion, cracks, cracks in welded joints, deformation, denting, wear, holes. A safety cue or label is missing.
- ! Never incorporate equipment or accessories not approved by L-Acoustics.**
- ! Read all the related PRODUCT INFORMATION documents shipped with the products before exploiting the system.**
- ! Do not store the product on an unstable cart, stand, tripod, bracket, or table.**
- ! Beware of sound levels.**
Do not stay within close proximity of loudspeakers in operation.
Loudspeaker systems are capable of producing very high sound pressure levels (SPL) which can instantaneously lead to permanent hearing damage to performers, production crew, and audience members. Hearing damage can also occur at moderate level with prolonged exposure to sound.
Check the applicable laws and regulations relating to maximum sound levels and exposure times.
- ! Risk of crushing injury**
Ensure that the wall or ceiling can support the load of the product.
It is recommended to mount only on solid structures. If mounting on a hollow structure (such as a wall cavity), place anchoring points on the framework (wall studs, ceiling joists), or reinforce the mounting area.
Select screws and anchors applicable to the wall or ceiling properties and to the load of the product. Prevent screws from loosening over time, using for example thread locker or lock washers.
- ! Risk of crushing injury**
When mounting the product on a ceiling using threaded rods, use lock nuts in addition to the mounting nuts to prevent the mounting nuts from loosening over time.
- ! Work with qualified personnel for rigging the system.**
Installation should only be carried out by qualified personnel that are familiar with the rigging techniques and safety recommendations outlined in this manual.
- Ensure personnel health and safety.**
During installation and set-up personnel must wear protective headgear and footwear at all times. Under no circumstances is personnel allowed to climb on a loudspeaker assembly.
- Respect the Working Load Limit (WLL) of third party equipment.**
L-Acoustics is not responsible for any rigging equipment and accessories provided by third party manufacturers. Verify that the Working Load Limit (WLL) of the suspension points, chain hoists and all additional hardware rigging accessories is respected.
- Respect the maximum configurations and the recommended safety precautions.**
For safety issue, respect the maximum configurations outlined in this manual. To check the conformity of any configuration in regards with the safety precautions recommended by L-Acoustics, model the system in Soundvision and refer to the warnings in Mechanical Data section.

Be cautious when flying a loudspeaker configuration.

Before installing/raising the product, check each individual element to make sure that it is securely fastened to the adjacent element. Always verify that no one is standing underneath the product when it is being installed/raised. Never leave the product unattended during the installation process.

As a general rule, L-Acoustics recommends the use of secondary safety at all times.

Be cautious when ground-stacking a loudspeaker array.

Do not stack the loudspeaker array on unstable ground or surface. If the array is stacked on a structure, platform, or stage, always check that the latter can support the total weight of the array.

As a general rule, L-Acoustics recommends the use of safety straps at all times.

Risk of falling objects

Verify that no unattached items remain on the product or assembly.

Risk of tipping

Remove all rigging accessories before transporting a product or an assembly.

Take into account the wind effects on dynamic load.

When a loudspeaker assembly is deployed in an open air environment, wind can produce dynamic stress to the rigging components and suspension points.

If the wind force exceeds 6 bft (Beaufort scale), lower down and/or secure the product or the assembly.

**Intended use**

This system is intended for use by trained personnel for professional applications.



As part of a continuous evolution of techniques and standards, L-Acoustics reserves the right to change the specifications of its products and the content of its documents without prior notice.

Check www.l-acoustics.com on a regular basis to download the latest document and software updates.



Long term exposure to extreme conditions may damage the product.

For more information, refer to the **Products weather protection** document, available on the website.



Read the maintenance section of this document before servicing the product.



Contact L-Acoustics for advanced maintenance.

Any unauthorized maintenance operation will void the product warranty.



This marking indicates that this product should not be disposed of with other household waste throughout the EU. To prevent possible harm to the environment or human health from uncontrolled waste disposal, recycle it responsibly to promote the sustainable reuse of material resources. To return your used device, please use the return and collection systems or contact the retailer where the product was purchased. They can take this product for environmentally safe recycling.



Introduction

X8i



X8i is a coaxial system designed for short throw installation applications that require discretion, elegance, and yet power. The slender and streamlined design of X8i facilitates its integration in high-end architectural settings where it provides clear, studio-like sound.

The passive loudspeaker features a 1.5" neodymium compression driver coaxially loaded by an 8" low frequency transducer in a bass-reflex cabinet. This coaxial arrangement produces a 90° axisymmetric directivity with a smooth tonal response free of secondary lobes over the entire frequency range.

X8i can be driven by two presets to adapt to the acoustic needs of projects and to subwoofer coupling configurations. For strong vocal reinforcement, or when used alongside a subwoofer, the [X8i] preset boasts 129 dB of max SPL, down to 67 Hz. For standalone applications and close proximity listening experience, the [X8i_40] preset delivers full range sound reproduction down to 43 Hz, and produces 123 dB of max SPL.

The combination of pristine yet powerful sound and elegant form makes X8i ideal for vocal or musical reinforcement in small theaters, live clubs, luxury and hospitality spaces, houses of worship, home & yacht, broadcast and recording studios.

How to use this manual

The X8i owner's manual is intended for all actors involved in the system design, implementation, preventive and corrective maintenance of the X8i system. It must be used as follows:

1. Read the technical description for an overview of all system elements, their features, and their compatibilities.
 - [Electro-acoustical description](#) (p.14)
 - [Rigging system description](#) (p.18)
2. Prepare the system configuration. Read the mechanical safety instructions and consider the available configurations, both mechanical and acoustical.
 - [Mechanical safety](#) (p.36)
 - [X8i mechanical configurations overview](#) (p.45)
 - [Loudspeaker configurations](#) (p.38)
3. Before rigging the system, perform mandatory inspections and functional checks.
4. To deploy the system, follow the step-by-step rigging instructions and refer to the cabling schemes.
 - [Rigging procedures](#) (p.45)
 - [Connection to LA amplified controllers](#) (p.169)

As part of a continuous evolution of techniques and standards, L-Acoustics reserves the right to change the specifications of its products and the content of its document without prior notice. Please check www.l-acoustics.com on a regular basis to download the latest document and software updates.





Contact information

For information on advanced corrective maintenance:

- contact your Certified Provider or your L-Acoustics representative
- for Certified Providers, contact the L-Acoustics customer service: customer.service@l-acoustics.com (EMEA/APAC), laus.service@l-acoustics.com (Americas).

Symbols

The following symbols are used in this document:

-  This symbol indicates a potential risk of harm to an individual or damage to the product. It can also notify the user about instructions that must be strictly followed to ensure safe installation or operation of the product.
-  This symbol indicates a potential risk of electrical injury. It can also notify the user about instructions that must be strictly followed to ensure safe installation or operation of the product.
-  This symbol notifies the user about instructions that must be strictly followed to ensure proper installation or operation of the product.
-  This symbol notifies the user about complementary information or optional instructions.

Revision history

version number	publication date	modification
1.0	Apr. 2024	Initial version.
2.0	Aug. 2024	<ul style="list-style-type: none">• Added new warning related to cable clip (X8i (p.18)).• Updated rigging procedures involving PAN accessory with TILT/TILTxx.• Updated Ceiling-mounting X8i vertically with VBAR and TILT5/TILT15/TILT40 (p.137).• Updated Flying X8i with X8i-HBAR (p.152).• Added Corrective maintenance (p.178).• Added corrections and improvements.

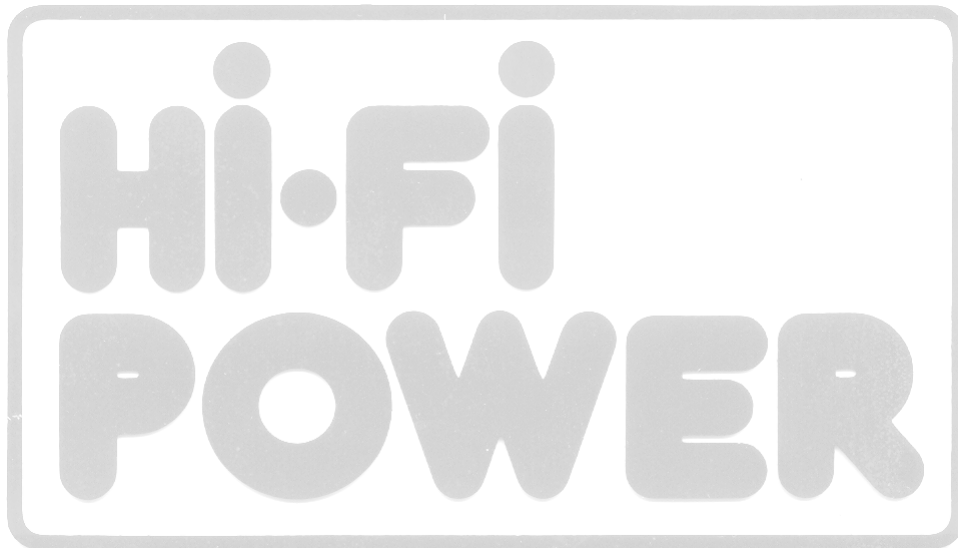

System components

Loudspeaker enclosures

X8i	2-way passive coaxial enclosure: 8" LF + 1.5" HF diaphragm (installation version)
SB10i	Ultra-compact subwoofer: 1 × 10" (installation version)
Syva Sub	Infra low frequency subwoofer: 1 × 12" LF
KS21	High power compact subwoofer: 1 × 21"



Refer to the Syva user documentation for information on using Syva Sub.

Powering and driving system

LA2Xi	Install-specific amplified controller 4 × 640 W / 4 ohms
LA4X	Amplified controller 4 × 1000 W / 8 ohms
LA7.16i	Install-specific amplified controller 16 × 1300 W / 8 ohms
LA12X	Amplified controller 4 × 2600 W / 4 ohms



Refer to the LA2Xi / LA4X / LA7.16i / LA12X owner's manual for operating instructions.

Cables

SPCON	2-point speakON adaptor (2.5 mm ² gauge) for terminal blocks
2 × 2.5 mm ² cable	Speaker cable with bare wire endings Adapt the cable length to the installation.
custom 2-point speakON cable	2-point speakON cable (2.5 mm ² gauge) to bare wire cable This cable needs to be custom made.



Information about the connection of the enclosures to the LA amplified controllers is given in this document.

Refer to the LA2Xi / LA4X / LA7.16i / LA12X owner's manual for detailed instructions about the whole cabling scheme, including modulation cables and network.

Rigging elements

X8i-onCW	On-wall or on-ceiling mounting accessory with silent blocks for X8i
WALLx2	Wall-mounting kit
PANx2	Adjustable pan accessory kit +/-45°
PAN	Adjustable pan accessory +/-45°
WALL	Wall-mounting accessory
TILT	Adjustable tilt accessory from 0° to 40°
TILT5	Fixed tilt accessory 5°
TILT15	Fixed tilt accessory 15°
TILT40	Fixed tilt accessory 40°
TILT-SUPPORT	Support plate for TILT/PAN/WALL accessories
GROUND	Ground-mounting accessory

GROUND55	Ground-mounting accessory for 55° site angle
GROUND35	Ground-mounting accessory for 35° site angle
X8i-HBAR	Rigging accessory for horizontally-oriented X8i
VBAR	Rigging accessory for vertically-oriented loudspeaker
CEILING-PENDANT	Rigging accessory for ceiling-hung pendant loudspeaker
POLE	Pole-mount adapter

Software applications

Soundvision	3D acoustical and mechanical modeling software
LA Network Manager	Software for remote control and monitoring of amplified controllers

i Refer to the Soundvision help.
i Refer to the LA Network Manager help.

System component illustrations

Cables

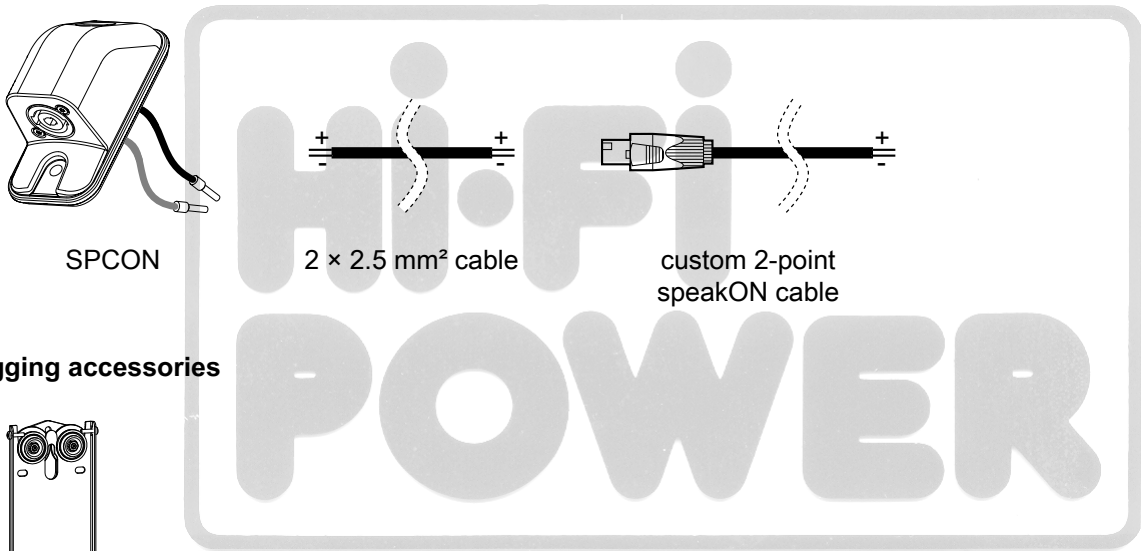

SPCON

2 × 2.5 mm² cable

custom 2-point speakON cable

Rigging accessories

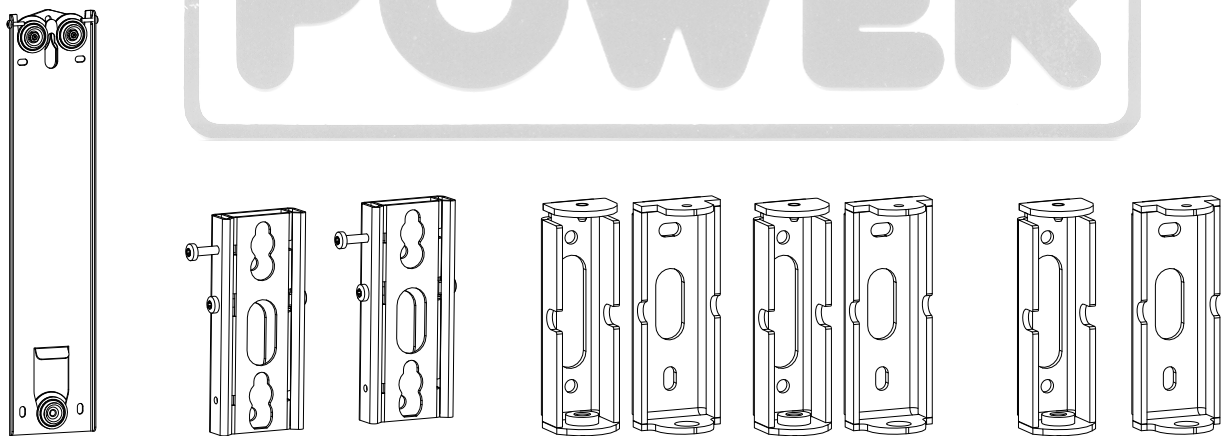

X8i-onCW

WALLx2

PANx2

PAN

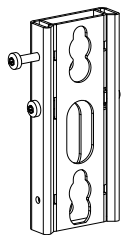

WALL

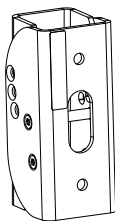

TILT

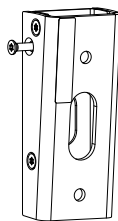

TILT5

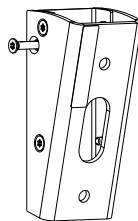

TILT15

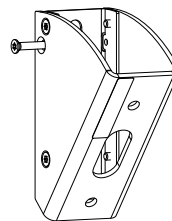

TILT40

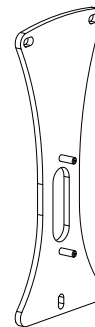

TILT-SUPPORT

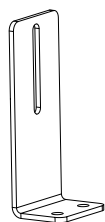

GROUND



GROUND55

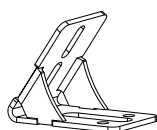

GROUND35

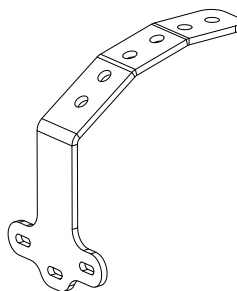

X8i-HBAR

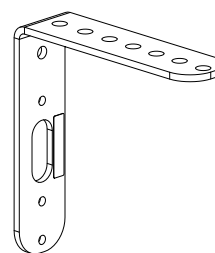

VBAR

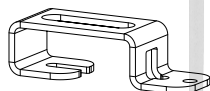

CEILING-PENDANT

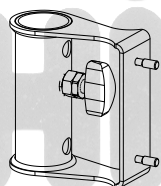

POLE

Software applications

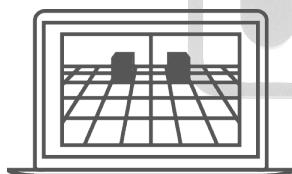

Soundvision



LA Network Manager

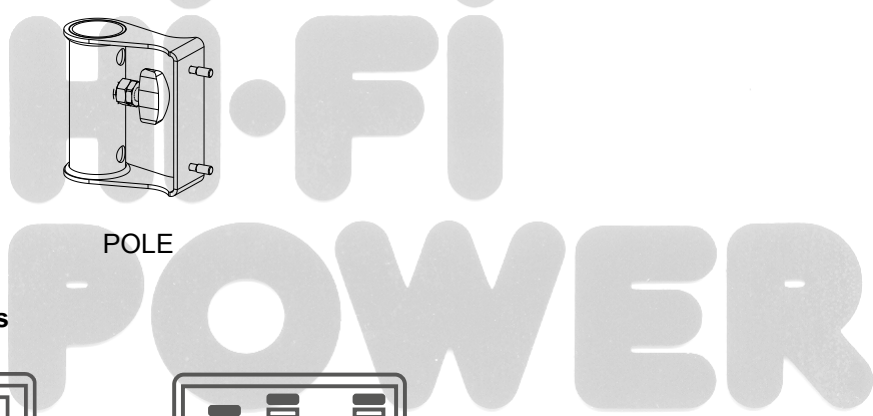

Electro-acoustical description

Directivity

X8i features a coaxial transducer arrangement that generates an axisymmetric directivity pattern of 90°.

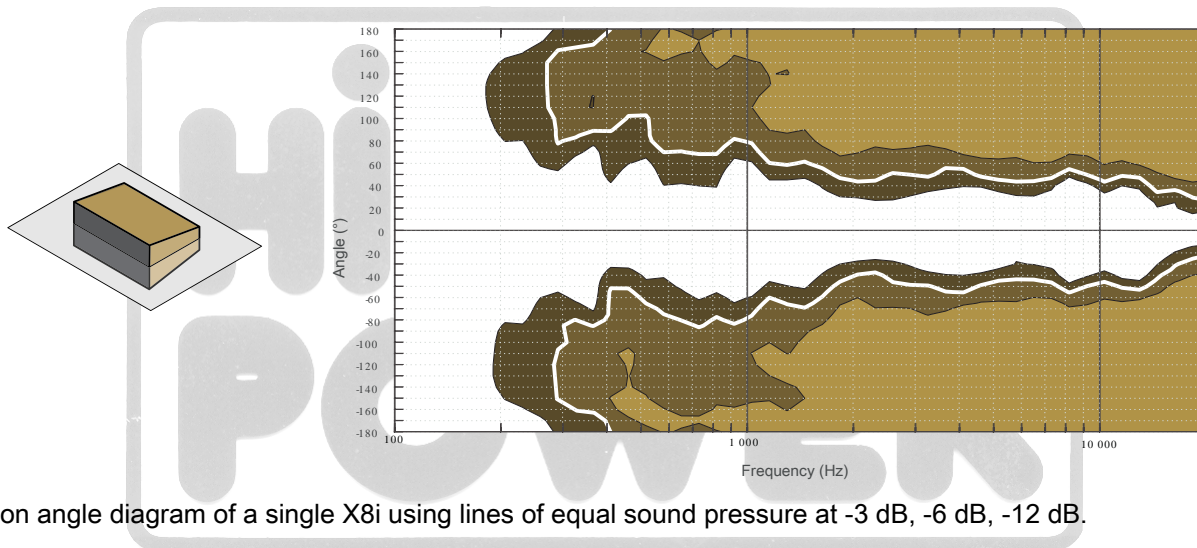
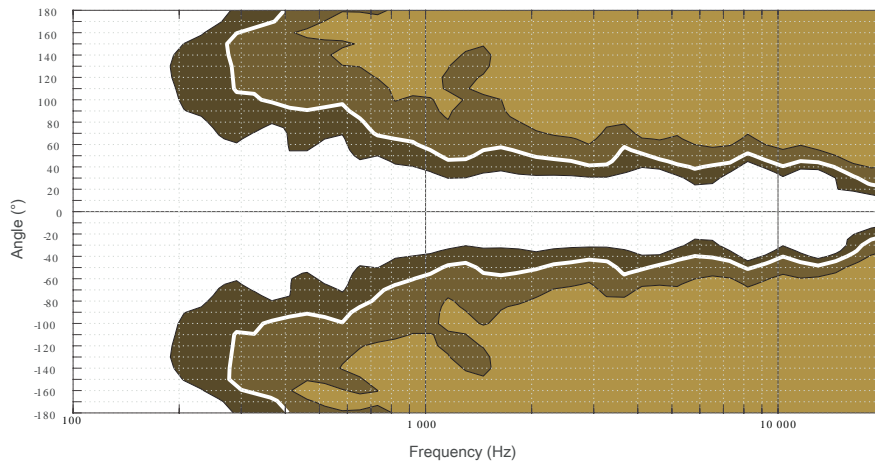
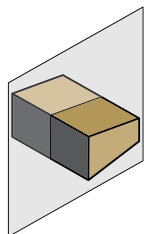

Dispersion angle diagram of a single X8i using lines of equal sound pressure at -3 dB, -6 dB, -12 dB.

Preset description

[X8i] [X8i_40] [X8i_MO]

outputs	channels	routing	gain	delay	polarity	mute
OUT 1	PA	IN A	0 dB	0 ms	+	ON
OUT 2	PA	IN A	0 dB	0 ms	+	ON
OUT 3	PA	IN B	0 dB	0 ms	+	ON
OUT 4	PA	IN B	0 dB	0 ms	+	ON

[KS21_100] [SB10_60] [SB10_100] [SYVA SUB_100]

outputs	channels	routing	gain	delay	polarity	mute
OUT 1	SB	IN A	0 dB	0 ms	+	ON
OUT 2	SB	IN A	0 dB	0 ms	+	ON
OUT 3	SB	IN A	0 dB	0 ms	+	ON
OUT 4	SB	IN A	0 dB	0 ms	+	ON

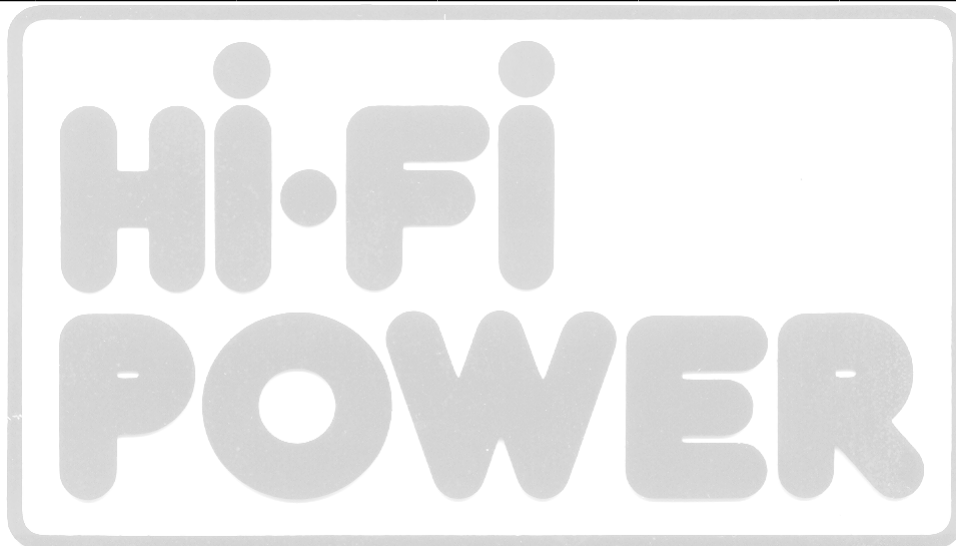

Connectors

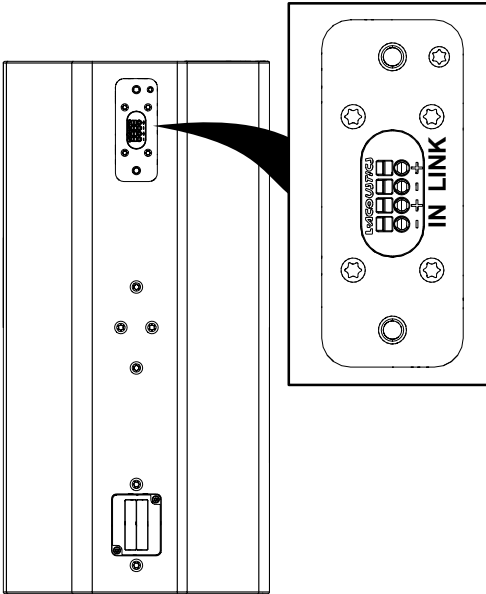

X8i

4-point terminal block with push-in connection

Internal pinout for L-Acoustics 2-way passive enclosures

Terminal block points	IN +	IN -
Transducer connectors	+	-

SPCON terminal block to speakON adapter

SPCON is a 2-point speakON to bare wire adaptor for X8i. The cables have a gauge of 2.5 mm² and the ends are equipped with ferrules. SPCON replaces the connector sealing plate.



Risk of electric shock

When SPCON is connected to an amplified controller, the bare wires carry electrical voltage.

Always mount SPCON to the enclosure **before** connecting the speaker cable to SPCON.

Always disconnect the speaker cable from SPCON **before** removing SPCON from the enclosure.

If the speaker cable cannot be disconnected, unplug the amplified controller from the mains.

SPCON is **not compatible** with the following rigging accessories:

- X8i-onCW
- WALLx2
- PANx2
- GROUND55
- GROUND35
- GROUND

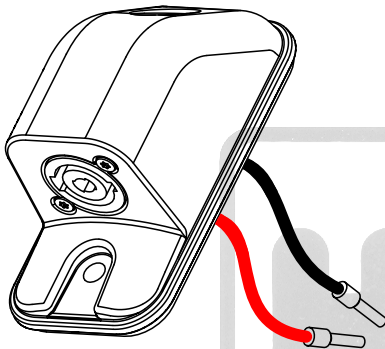

SPCON

2-point speakON

hi-fi
POWER

Rigging system description

X8i

X8i is a loudspeaker enclosure dedicated for installation projects. X8i can be mounted on a wall, on a ceiling, flown, or secured to the ground with dedicated rigging accessories, using the inserts at the back.

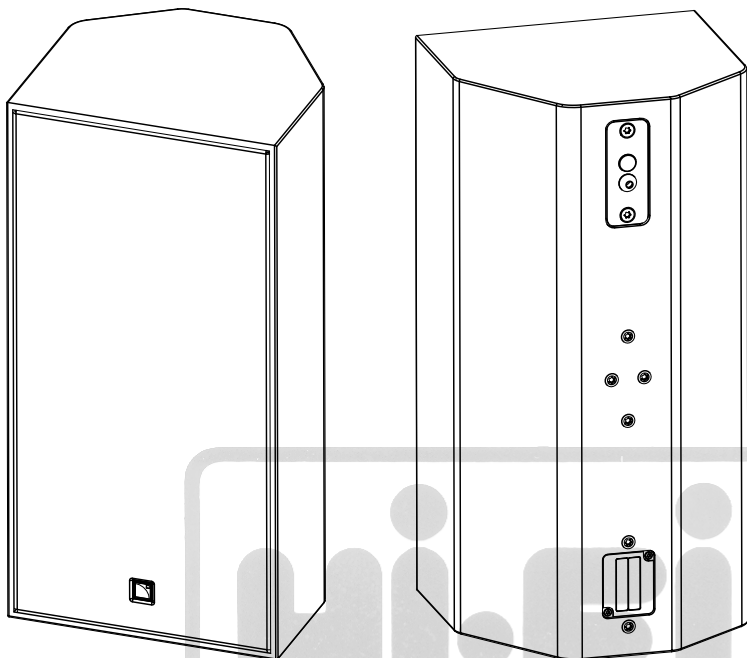

! Secondary safety for flown, wall-mounted, or ceiling-mounted enclosures

Use one insert at the back of the enclosure to implement a secondary safety.

! Risk of acoustic leaks

Always put the placeholder screws back in place when the inserts are not in use.

The logo on the grill can be rotated to adapt to every position.

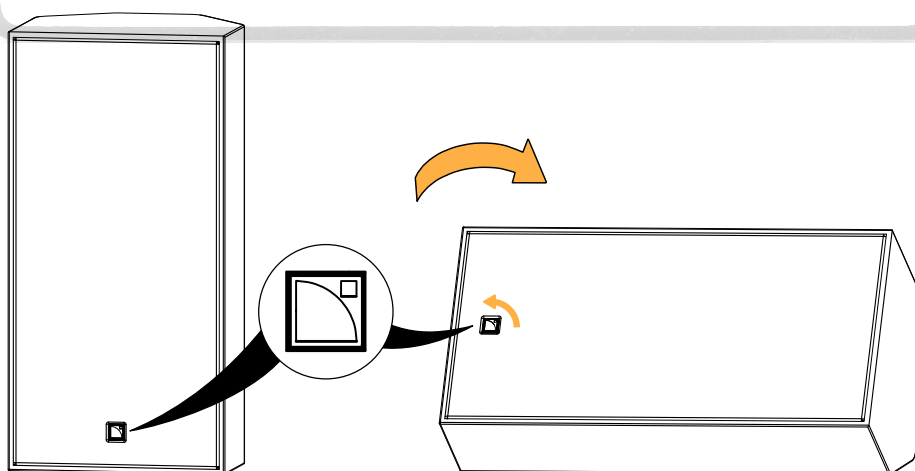

! Weather resistance

X8i reaches IP55 protection level when it is in the vertical position, with the connector at the top.

When on the ground, the shape of the cabinet provides three possible monitor angles: 0°, 35°, or 55°. Ground-mounting accessories can be used for more stability, see [GROUND / GROUND35 / GROUND55](#) (p.34).

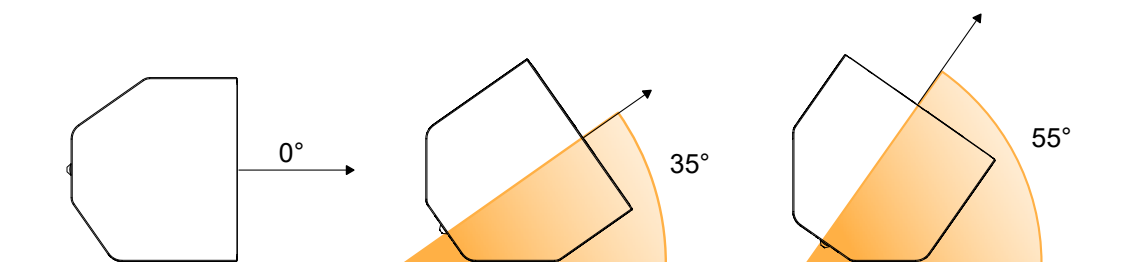

X8i includes a cable clip to run the speaker cable along the cabinet. Mount the cable clip on any available insert in the middle of the enclosure with the provided M6×20 Torx screw.

! Do not mount the cable clip on a rigging accessory.

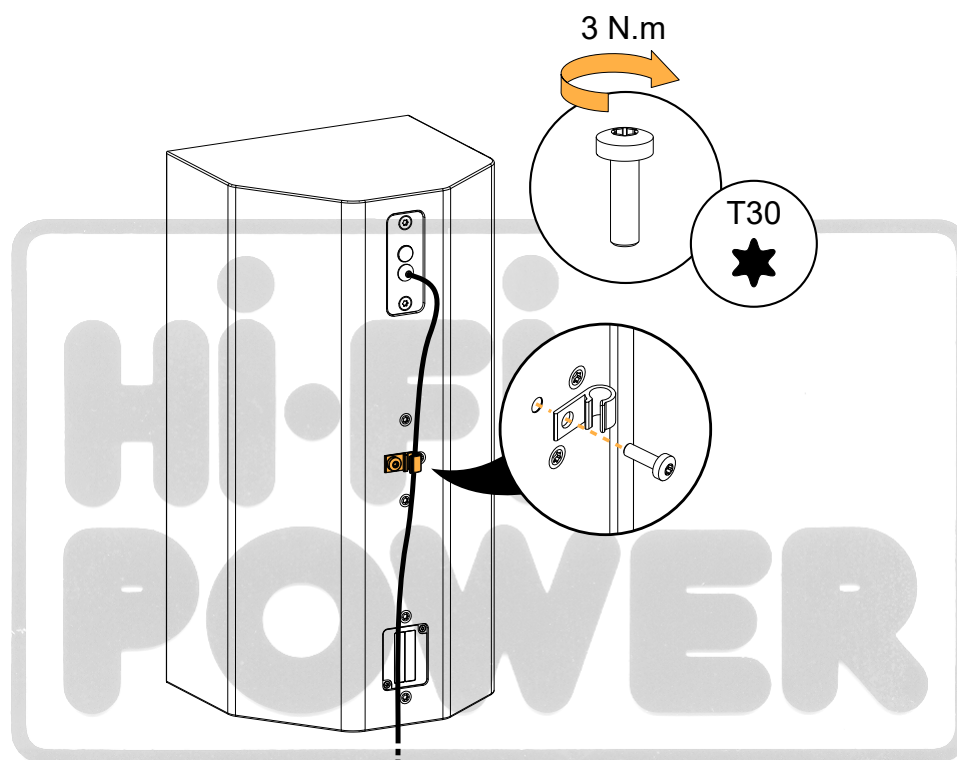

Elements for wall-mounting



Risk of crushing injury

Ensure that the wall or ceiling can support the load of the product.

It is recommended to mount only on solid structures. If mounting on a hollow structure (such as a wall cavity), place anchoring points on the framework (wall studs, ceiling joists), or reinforce the mounting area.

Select screws and anchors applicable to the wall or ceiling properties and to the load of the product. Prevent screws from loosening over time, using for example thread locker or lock washers.

Refer to [APPENDIX A: Specifications for screws and anchors](#) (p.209).

TILT-SUPPORT

TILT-SUPPORT is a support plate for individual X8i wall-mounting accessories. TILT-SUPPORT must be used to ensure the safety of the assembly with WALL, PAN, TILT5, TILT15, TILT40, or TILT.

TILT-SUPPORT is composed of:

- a main part with two M5 self-clinching studs
- fasteners for assembly

TILT-SUPPORT features three Ø 6.4 mm / 0.25 in slotted holes for vertical and horizontal adjustment during installation.

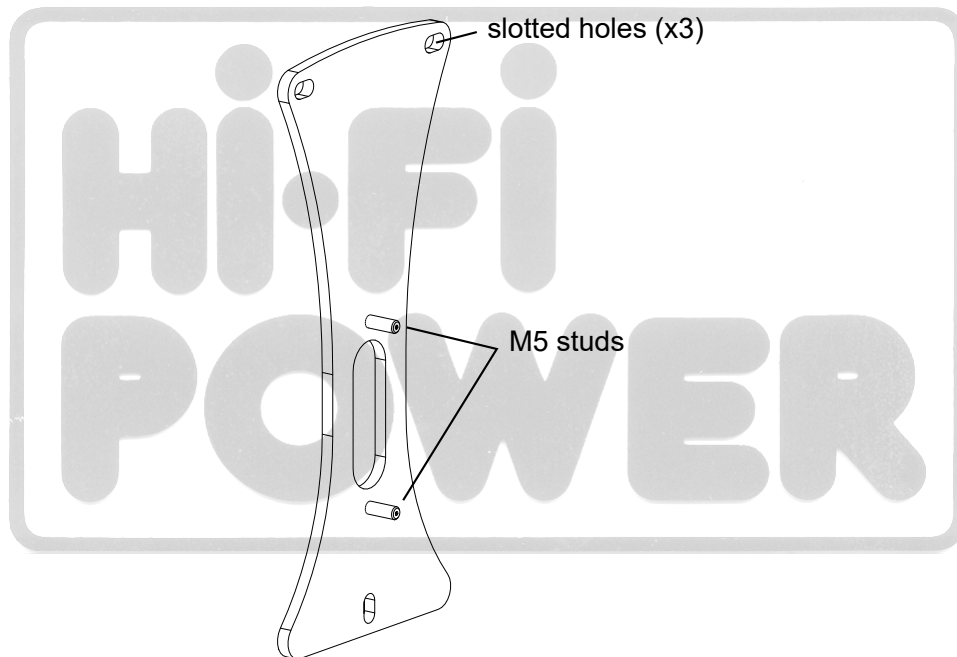

TILT-SUPPORT fasteners



x2



x2

M5 hex locknut

thick plain washer Ø
5 mm

X8i-onCW

X8i-onCW is a rigging interface with silent blocks for mounting one X8i on a wall or on a ceiling. X8i-onCW is composed of:

- one surface-mounting plate
- three silent blocks:
 - one enclosure-mounting plate with two silent blocks
 - one individual silent block
- fasteners for assembly and safety

The silent blocks isolate the enclosure from the wall to reduce the transmission of vibrations and improve sound quality.

X8i-onCW features four \varnothing 6.4 mm / 0.25 in slotted holes for vertical and horizontal adjustment during installation. Four flat M6 washers are provided for depth adjustment on uneven surfaces.

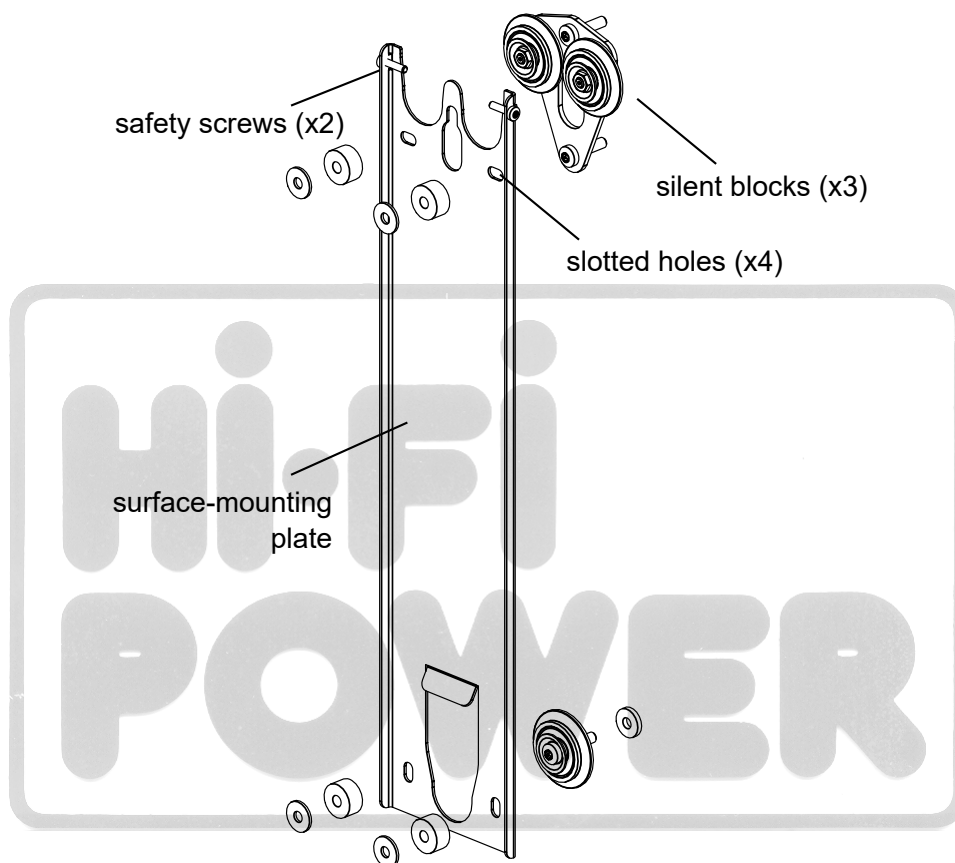

X8i-onCW screws and fasteners

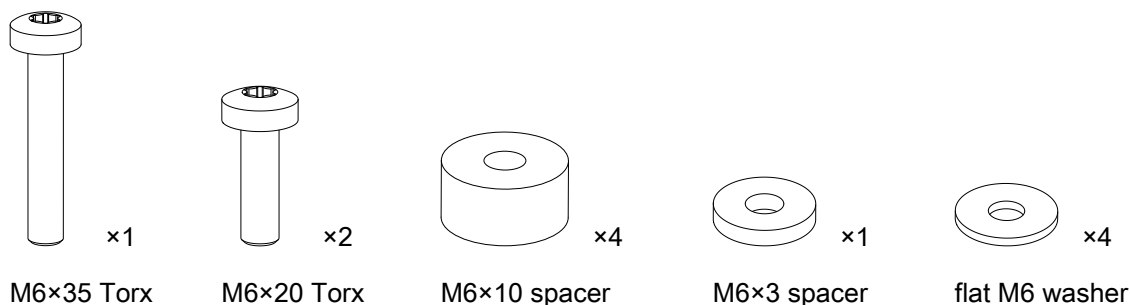

WALL

WALL is a rigging interface for mounting one X8i horizontally on a wall. It must be used in combination with [TILT-SUPPORT](#) (p.20). WALL is composed of:

- a main part for mounting on X8i
- a rectangular washer
- a wall-mounting plate
- fasteners for assembly and safety

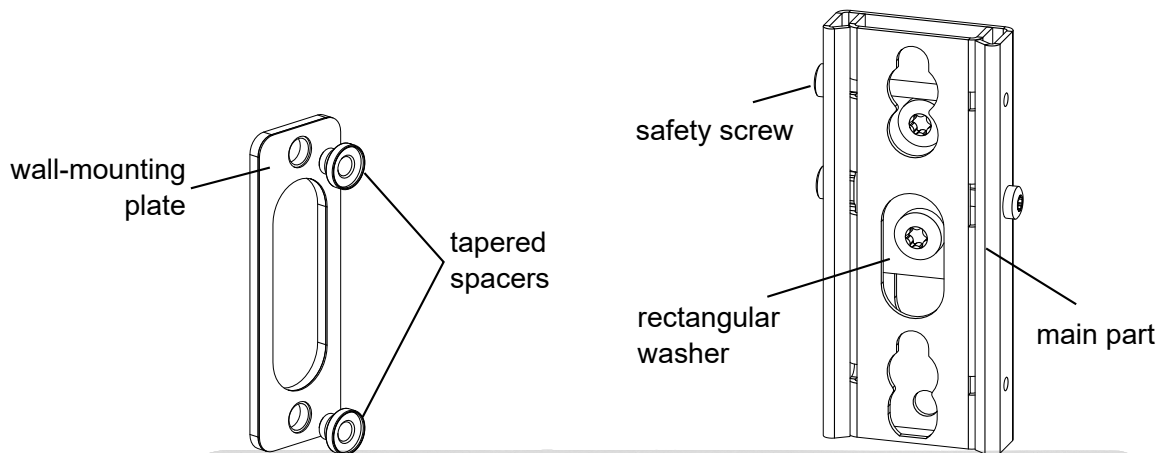

i To mount X8i vertically on a wall, use [WALLx2](#) (p.23) instead.

WALL screws and fasteners



WALLx2

WALLx2 is a rigging interface for mounting one X8i vertically on a wall. WALLx2 is composed of two WALL (p.22), without rectangular washers:

- two main parts for mounting on X8i
- two wall-mounting plates
- fasteners for assembly and safety

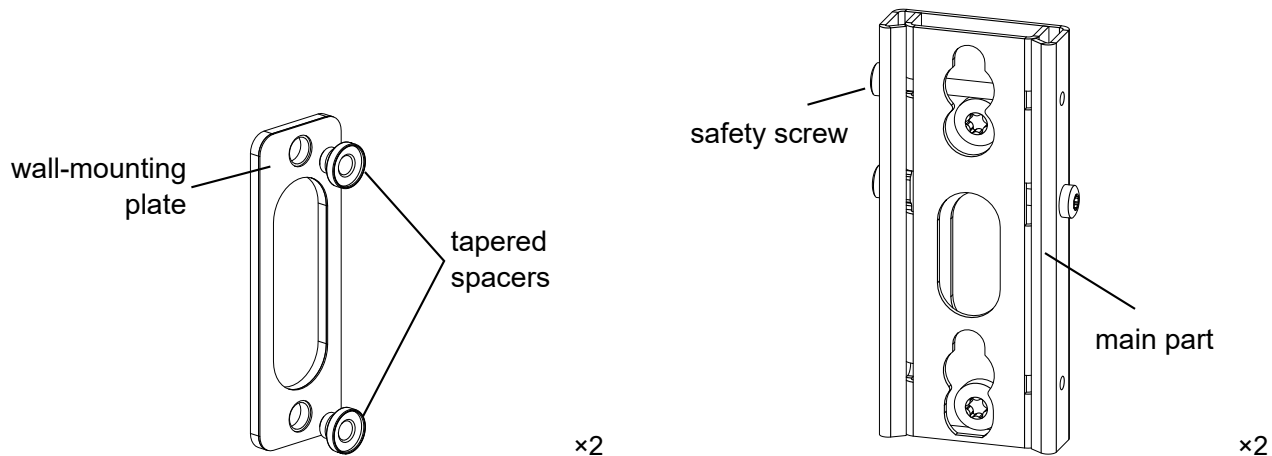

WALLx2 screws and fasteners

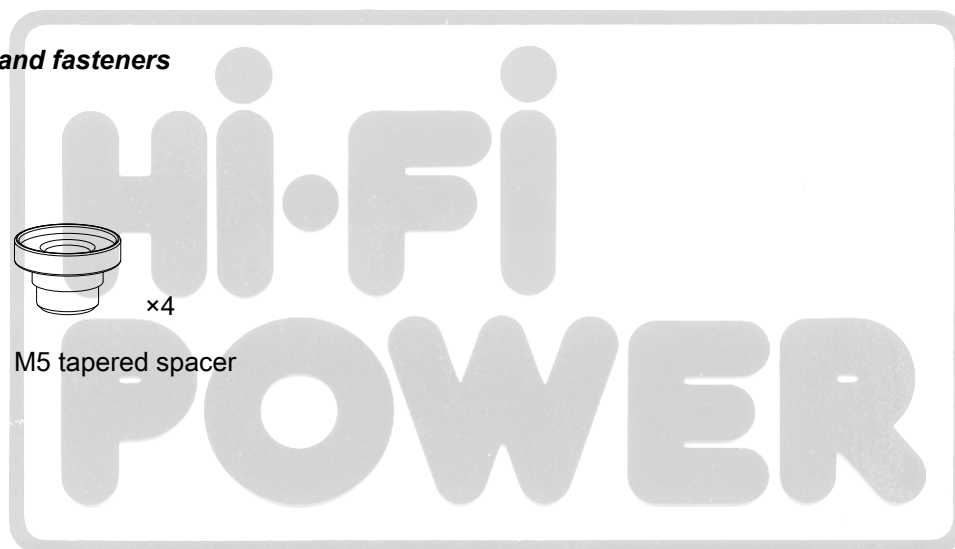
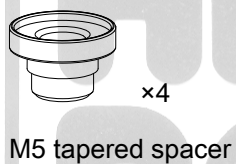
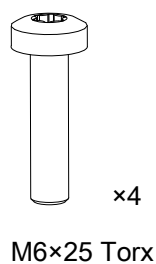

Elements for ceiling-mounting or truss-mounting



Risk of crushing injury

Ensure that the wall or ceiling can support the load of the product.

It is recommended to mount only on solid structures. If mounting on a hollow structure (such as a wall cavity), place anchoring points on the framework (wall studs, ceiling joists), or reinforce the mounting area.

Select screws and anchors applicable to the wall or ceiling properties and to the load of the product. Prevent screws from loosening over time, using for example thread locker or lock washers.

Refer to [APPENDIX A: Specifications for screws and anchors](#) (p.209).

VBAR

VBAR is a rigging bracket for mounting X8i vertically on the ceiling, or for flying X8i with a truss or a threaded rod in a suspended ceiling.

VBAR can be combined with TILT, TILT5, TILT15, or TILT40 to adjust the site angle when mounting X8i on the ceiling.

VBAR has seven \varnothing 10.4 mm / 0.41 in possible pickup points for site angle setting in flown configuration. When mounting on the ceiling, drive two screws in holes 1 and 7.



Ceiling-mounting holes

When ceiling-mounting with VBAR, always use holes 1 and 7 (at both ends) to ensure optimal support.

A \varnothing 9 mm / 0.35 in hole is available at the top of VBAR to run the speaker cable above X8i.

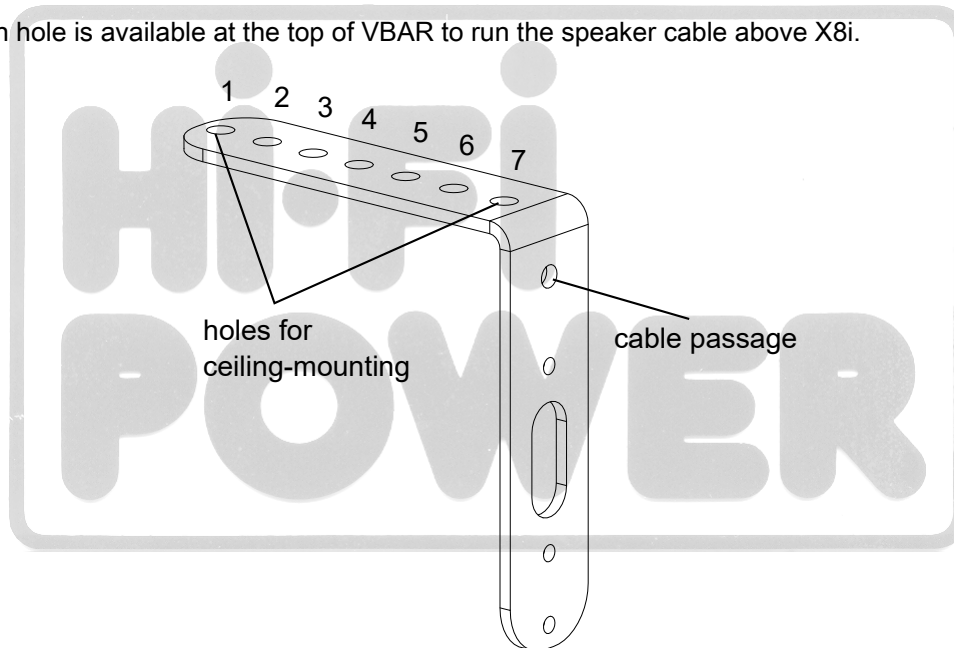

VBAR screws and fasteners

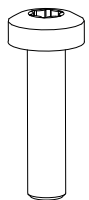

x2

M6×25 Torx



x2

flat washer \varnothing 6 mm



x2

M6 hex lock nut

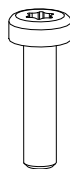

x2

M5×20 Torx



x2

thick plain washer \varnothing 5 mm



x2

M5 hex locknut

X8i site angles when flown or truss-mounted with VBAR

hole N°	angle
1	9°
2	5°
3	0°
4	-4°
5	-9°
6	-13°
7	-17°

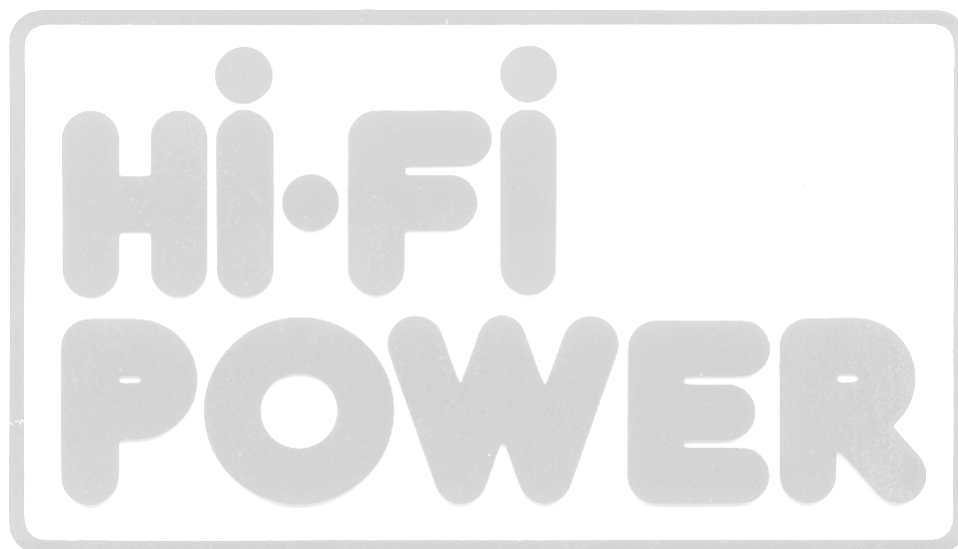

X8i-HBAR

X8i-HBAR is a rigging bracket for mounting X8i horizontally on the ceiling, or for flying X8i with a truss or a threaded rod in a suspended ceiling.

X8i-HBAR has six $\varnothing 10.3$ mm / 0.40 in possible pickup points for site angle setting in flown configuration. When mounting on the ceiling, use one pair of adjacent, coplanar holes depending on the chosen site angle.

X8i-HBAR can be mounted on a horizontal X8i turned either way:

- with the connector plate on the right-hand side:

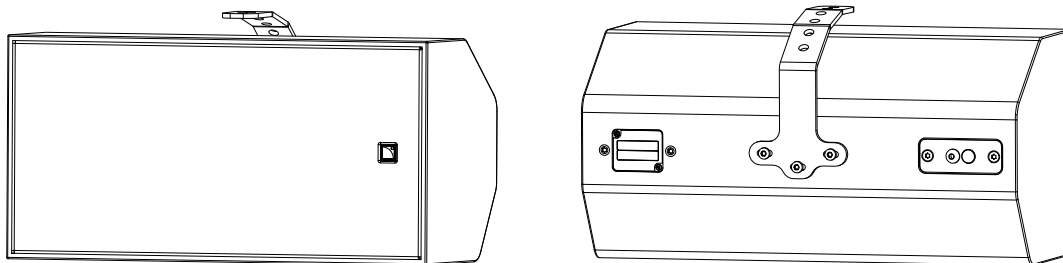

- with the connector plate on the left-hand side:

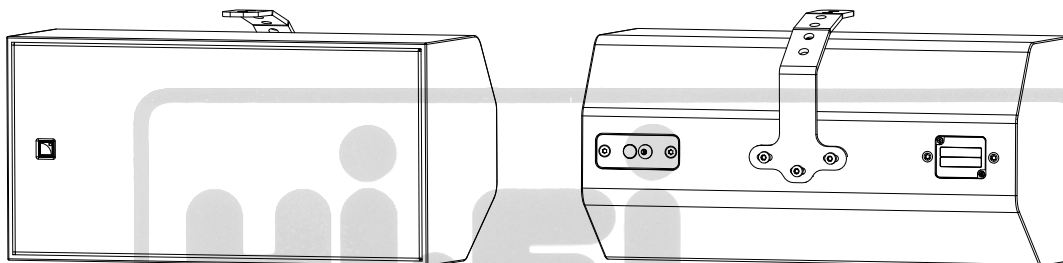

X8i-HBAR has three slotted holes for mounting on X8i to adjust the roll angle.

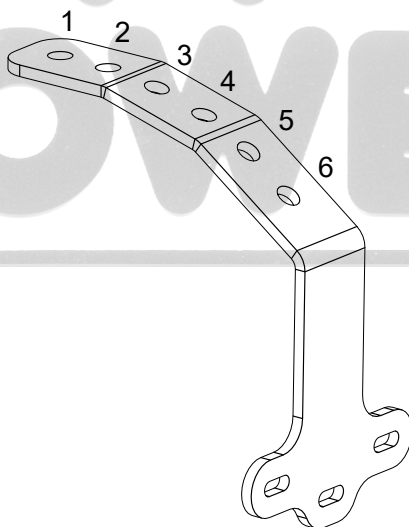

X8i-HBAR screws

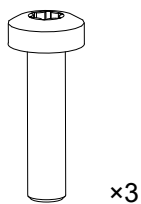

M6x25 Torx

X8i site angles when flown or truss-mounted with X8i-HBAR

hole N°	angle
1	9°
2	1°
3	-10°
4	-20°
5	-30°
6	-40°

X8i site angles when ceiling-mounted with X8i-HBAR

holes N°	angle
1 + 2	0°
3 + 4	-14°
5 + 6	-35°

CEILING-PENDANT

CEILING-PENDANT is a rigging accessory for flying X8i in downward-facing position with a truss or a threaded rod in a suspended ceiling.

The slotted hole at the top has a diameter of \varnothing 12 mm / 0.47 in.

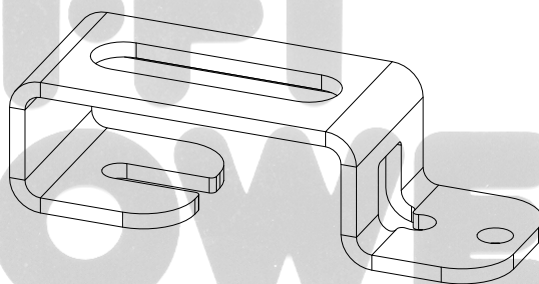
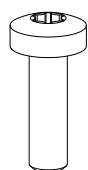
**CEILING-PENDANT screws**

x2

M6×20 Torx

Elements for site or azimuth angle adjustment

Risk of crushing injury

Ensure that the wall or ceiling can support the load of the product.

It is recommended to mount only on solid structures. If mounting on a hollow structure (such as a wall cavity), place anchoring points on the framework (wall studs, ceiling joists), or reinforce the mounting area.

Select screws and anchors applicable to the wall or ceiling properties and to the load of the product. Prevent screws from loosening over time, using for example thread locker or lock washers.

Refer to [APPENDIX A: Specifications for screws and anchors](#) (p.209).

TILT5 / TILT15 / TILT40

TILT5, TILT15, and TILT40 are rigging interfaces for mounting one X8i vertically or horizontally with a fixed site angle of 5°, 15°, or 40° respectively. They must be used in combination with [TILT-SUPPORT](#) (p.20) or [VBAR](#) (p.24). Optionally, TILT5, TILT15, or TILT40 can be combined with [PAN](#) (p.32) to mount X8i with site and azimuth angle.

TILT5, TILT15, and TILT40 are composed of:

- a main part for mounting on X8i
- a wall-mounting plate
- a rectangular washer for horizontal configurations
- fasteners for assembly and safety

Risk of falling objects

Do not use TILT, TILT5, TILT15, or TILT40 upside-down. These rigging accessories are designed for negative site angles only.

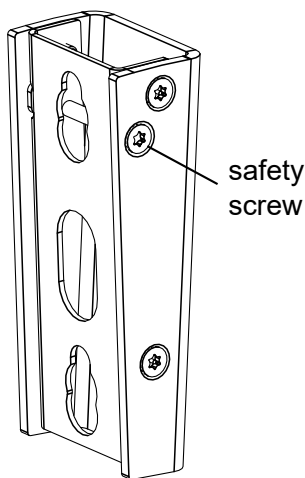
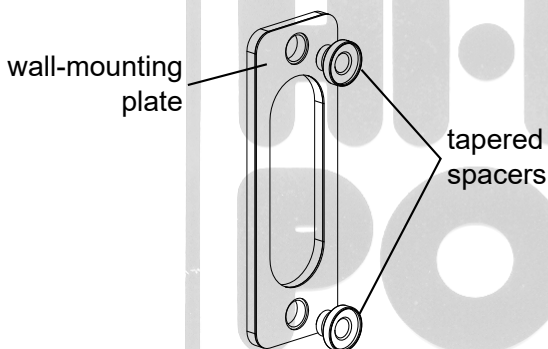

TILT5

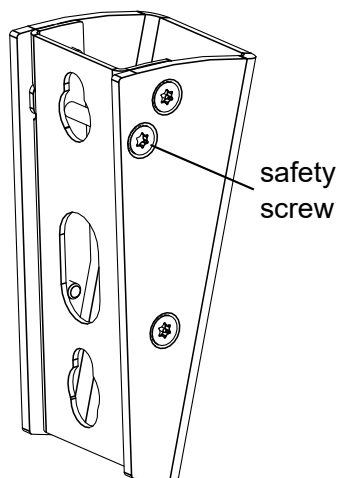

TILT15

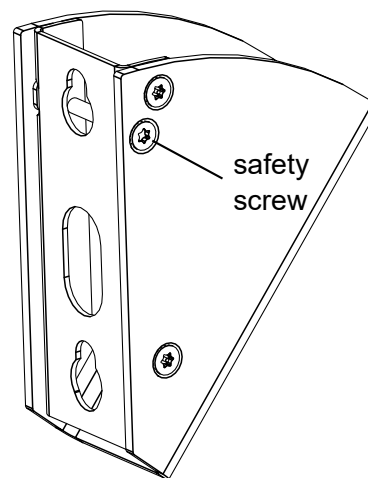

TILT40

TILT5 / TILT15 / TILT40 screws and fasteners

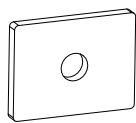

x1

rectangular washer

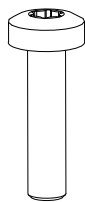

x2

M6x25 Torx



x2

M5 tapered spacer

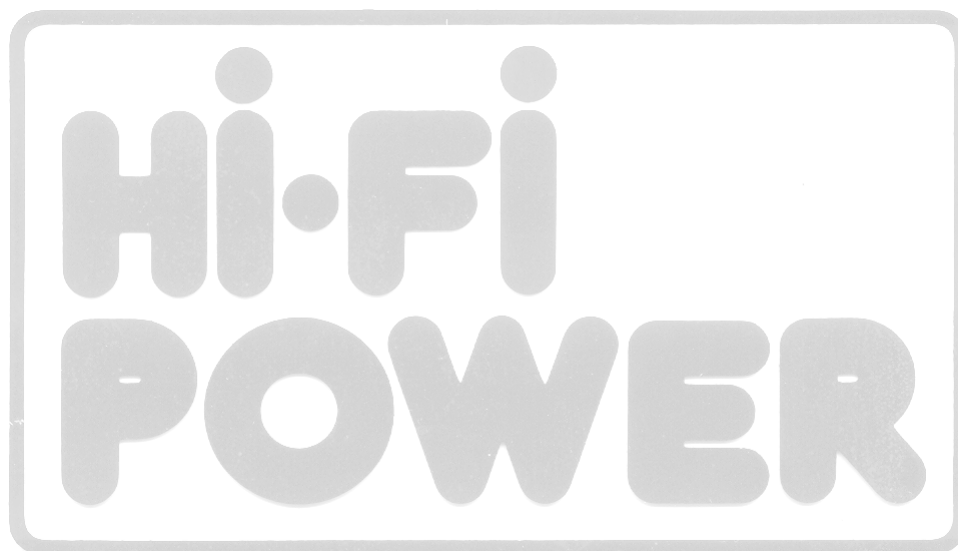

TILT

TILT is a rigging interface for mounting X8i vertically or horizontally with an adjustable site angle. It must be used in combination with **TILT-SUPPORT** (p.20) or **VBAR** (p.24). Optionally, TILT can be combined with **PAN** (p.32) to mount X8i with site and azimuth angle.

TILT is composed of:

- a main part for mounting on X8i
- a wall-mounting part
- a rectangular washer for horizontal configurations
- fasteners for assembly and safety

⚠ Risk of falling objects
Do not use TILT, TILT5, TILT15, or TILT40 upside-down. These rigging accessories are designed for negative site angles only.

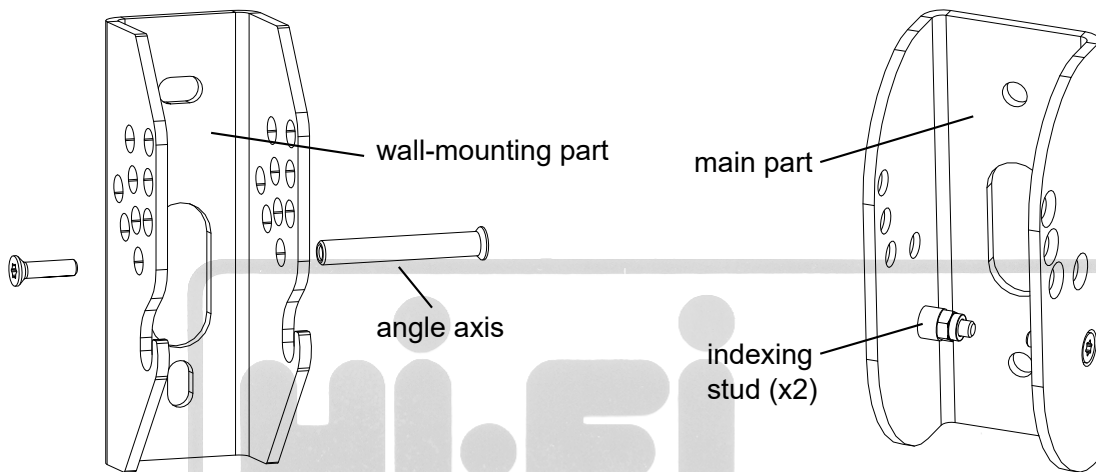

TILT screws and fasteners

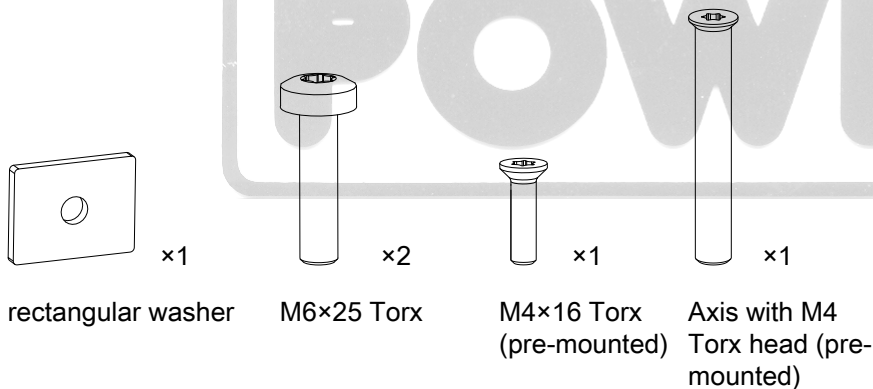

The enclosure site angle can be adjusted from 0° to -40° in 5° steps.

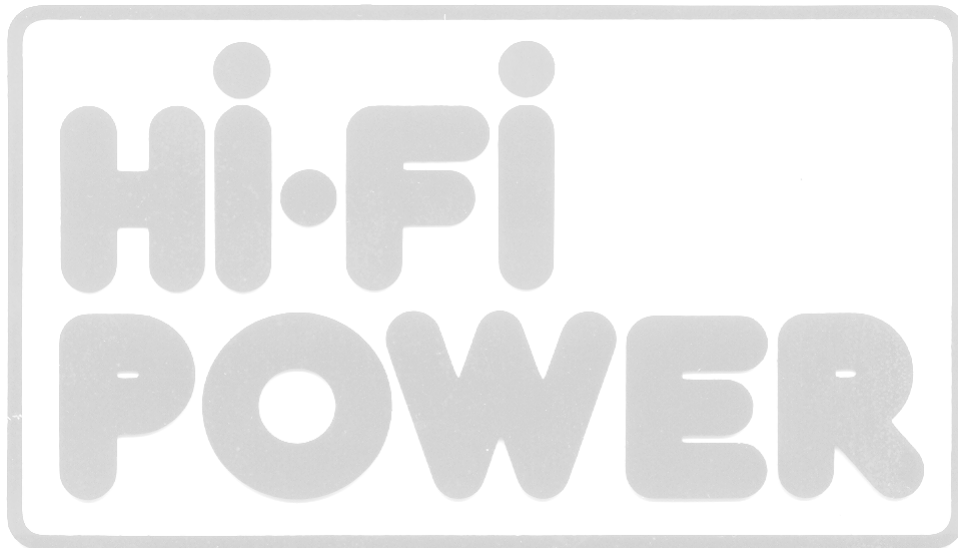
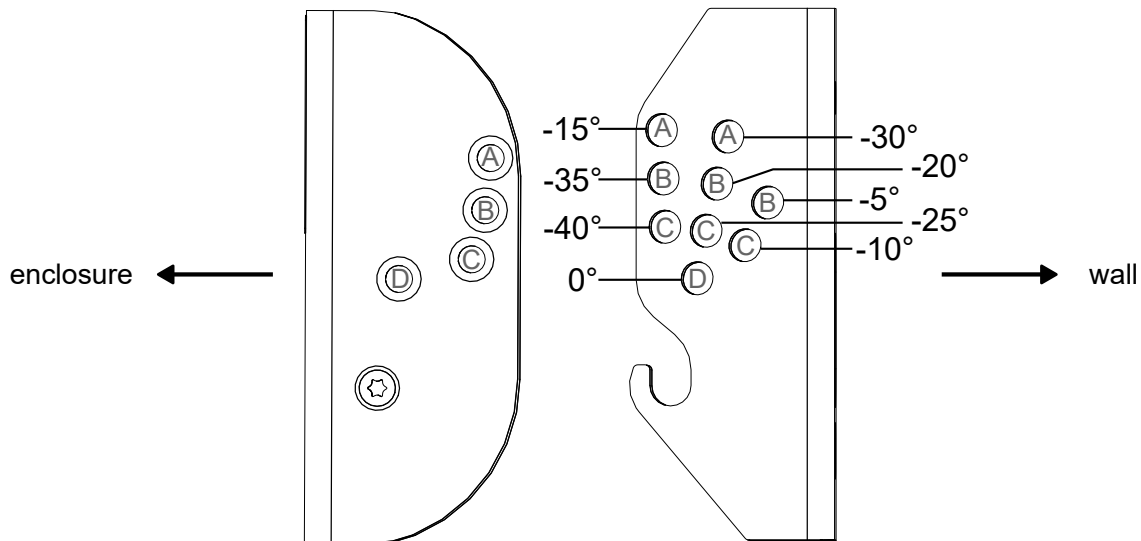

PAN

PAN is a rigging interface for mounting one X8i horizontally on a wall with adjustable azimuth angle. It must be used in combination with [TILT-SUPPORT](#) (p.20).

PAN can be combined with TILT, TILT5, TILT15, or TILT40 to mount X8i horizontally or vertically with site and azimuth angle.

The azimuth angle can be set between -45° and 45°.

PAN is composed of:

- a main part for mounting on X8i
- a wall-mounting part
- a rectangular washer for horizontal configurations
- fasteners for assembly and safety



Risk of falling objects

Do not use PAN or PANx2 upside-down.

Do not swap the wall-mounting part(s) and the enclosure-mounting part(s).

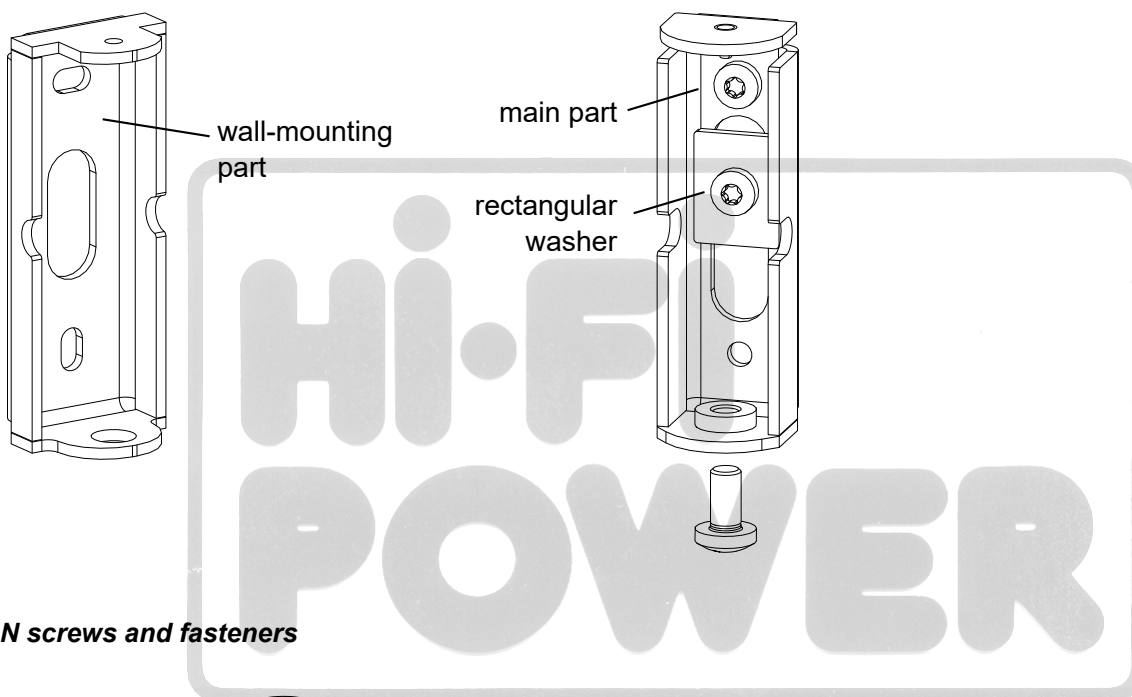

PAN screws and fasteners

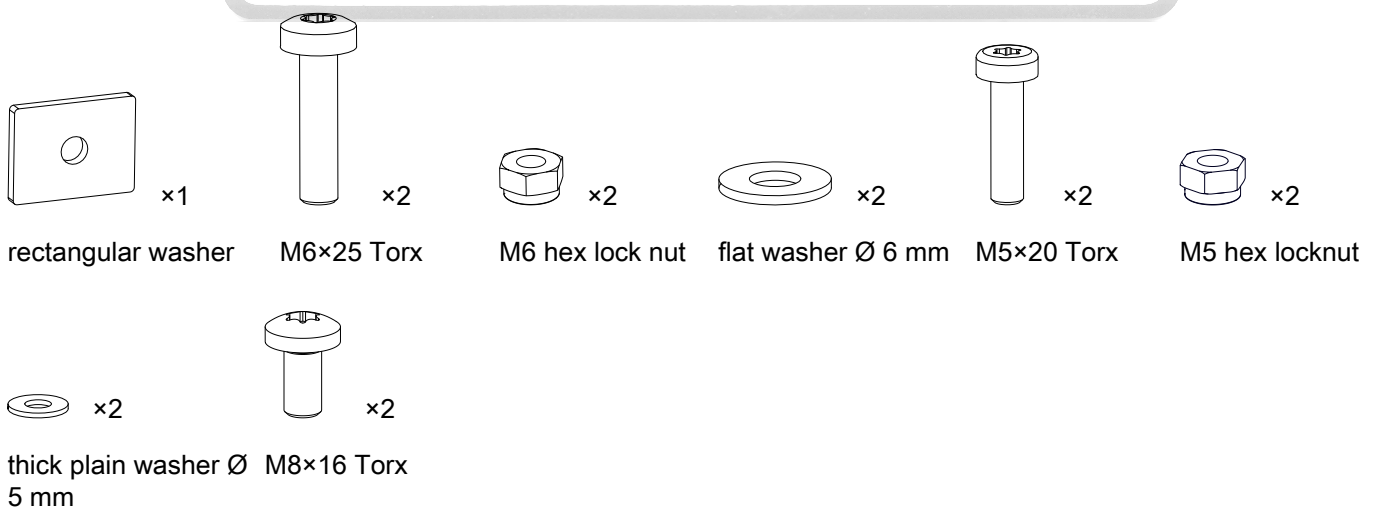

To mount X8i vertically on a wall with adjustable azimuth angle and without site angle setting, use [PANx2](#) (p.33) instead.

PANx2

PANx2 is a rigging interface for mounting one X8i vertically on a wall with adjustable azimuth angle. It is composed of two PAN (p.32), without the fasteners for combinations with TILT accessories or horizontal configurations:

- two main parts for mounting on X8i
- two wall-mounting parts
- fasteners for assembly and safety

The azimuth angle can be set between -45° and 45°.



Risk of falling objects

Do not use PAN or PANx2 upside-down.

Do not swap the wall-mounting part(s) and the enclosure-mounting part(s).

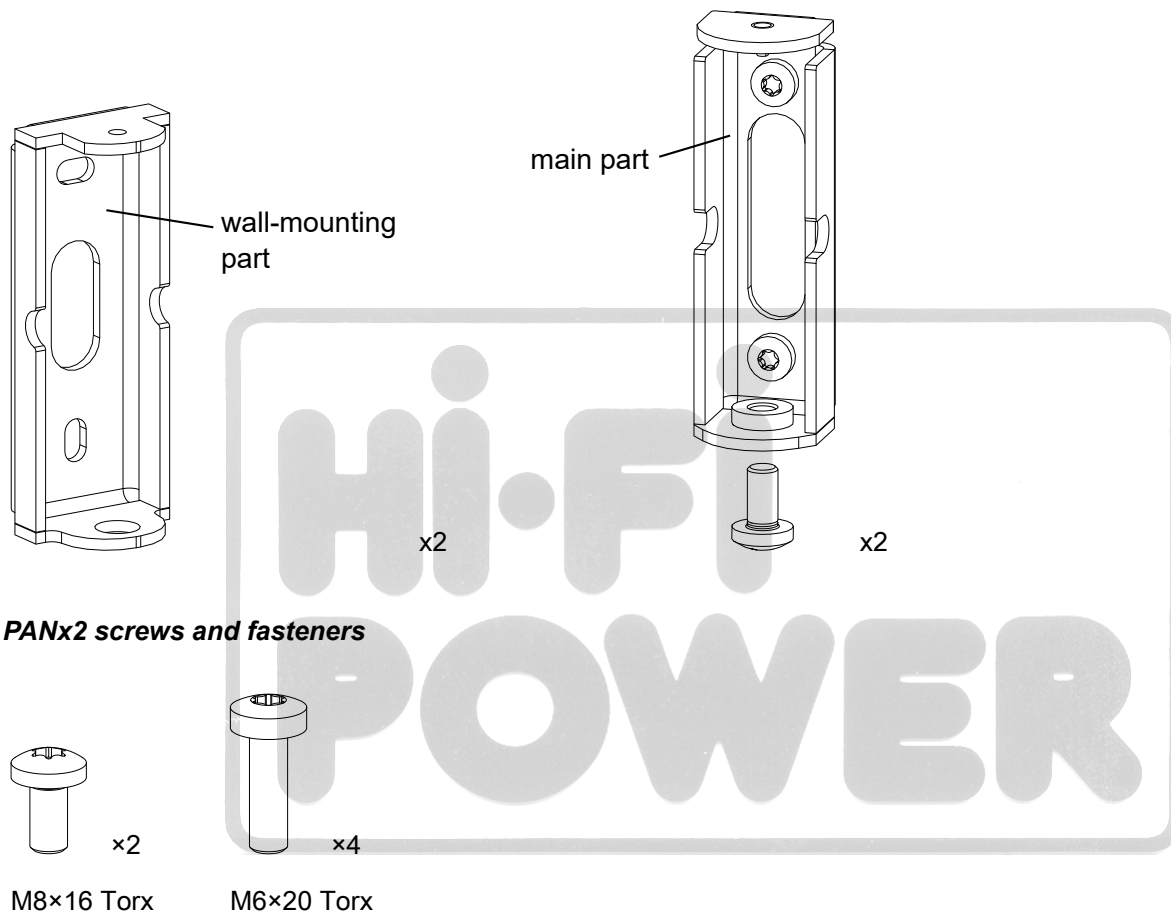

Elements for ground-mounting

GROUND / GROUND35 / GROUND55

GROUND, GROUND35, and GROUND55 are accessories for securing X8i to the ground with a site angle of 0°, 35°, or 55° respectively.

Two \varnothing 6.4 mm / 0.25 in holes are available for ground-mounting the enclosure.

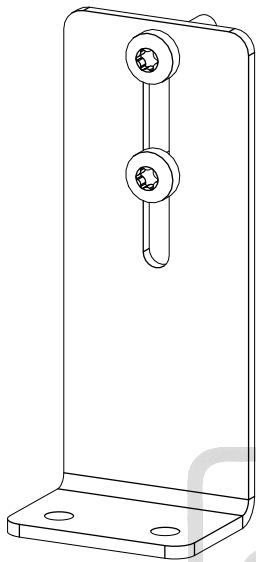

GROUND

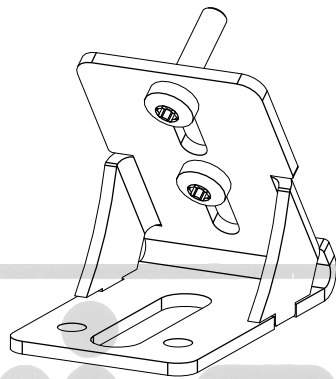

GROUND35

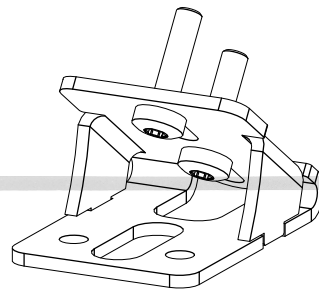

GROUND55

GROUND / GROUND35 / GROUND55 screws and fasteners

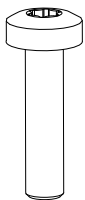

x2

M6x25 Torx

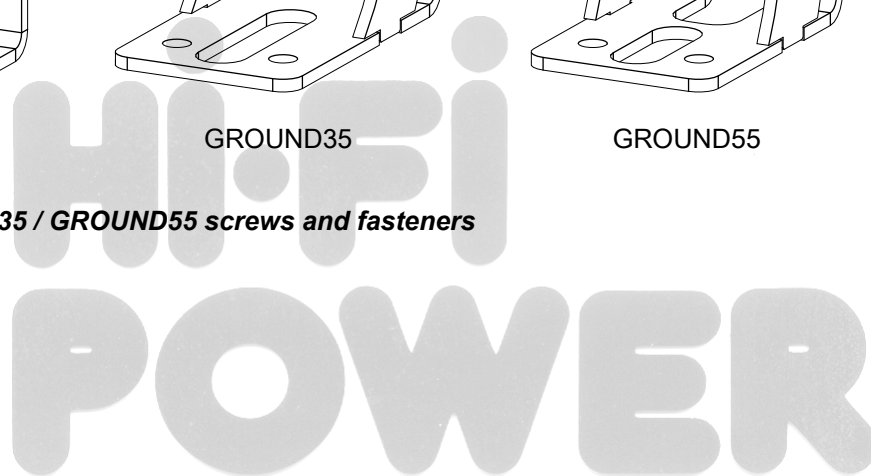

Elements for pole-mounting

POLE

POLE is a rigging accessory for mounting X8i on a \varnothing 35 mm (1-3/8") pole.

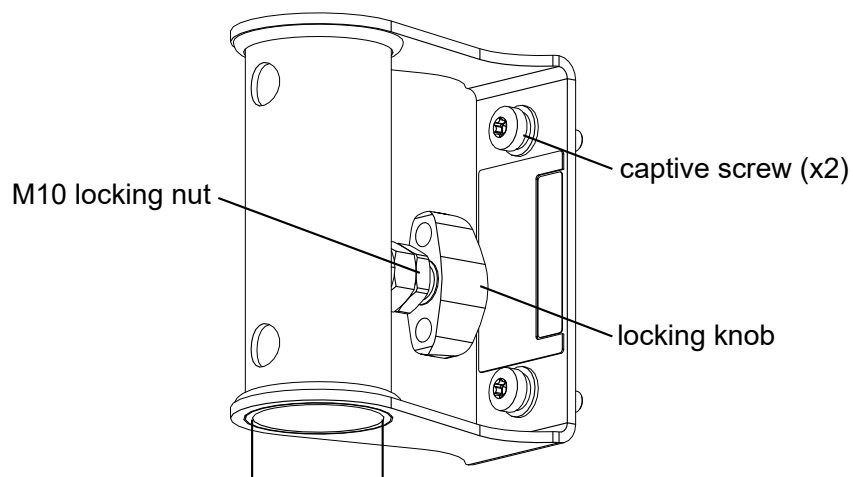

\varnothing 35 mm / 1-3/8"
pole-mount
adapter

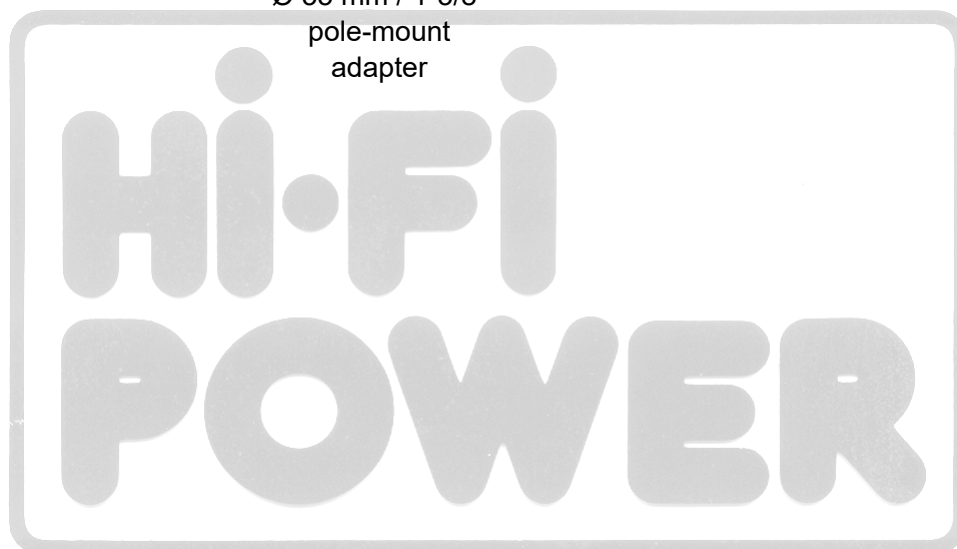





Mechanical safety

Flown configurations

The X8i rigging system complies with EN 62368-1: 2014 Audio/video, information and communication technology equipment — Part 1: Safety requirements.

The deployments described in this manual achieve a safety factor of 5.

-  **Safe/maximum limit: 1**
All the mechanical configurations described in this manual are destined to mount a single X8i.
-  **Risk of injury or product damage**
This manual describes all allowed mechanical configurations with X8i and its accessories.
Do not attempt to use these products outside of their intended use.
-  **Mechanical configurations overview**
For a detailed list of X8i mechanical configurations, refer to [X8i mechanical configurations overview](#) (p.45).
-  In this table, TILTxx designates the fixed angle accessories TILT5, TILT15, and TILT40.

X8i

configuration		deployment parameters			
		site angle			adjustable azimuth angle
mode	orientation	0° angle	adjustable angle	fixed angle	
wall-mounted	vertical	<ul style="list-style-type: none"> X8i-onCW* WALLx2 	TILT-SUPPORT + TILT	TILT-SUPPORT + TILTxx	<ul style="list-style-type: none"> PANx2 With site angle setting: TILT-SUPPORT + PAN + TILT / TILTxx
	horizontal	TILT-SUPPORT + WALL	TILT-SUPPORT + TILT	TILT-SUPPORT + TILTxx	<ul style="list-style-type: none"> TILT-SUPPORT + PAN With site angle setting: TILT-SUPPORT + PAN + TILT / TILTxx
ceiling-mounted	vertical	VBAR	VBAR + TILT	VBAR + TILTxx	–
	horizontal	X8i-HBAR		X8i-onCW*	–
truss-mounted / suspended by a threaded rod	vertical	VBAR		CEILING-PENDANT	–
	horizontal	X8i-HBAR			–

* with silent blocks

Other configurations

X8i

configuration		deployment parameters	
		site angle	
mode	orientation	0° angle	fixed angle
grounded	vertical	no rigging accessory	–
	horizontal	GROUND	GROUND55 (55°) / GROUND35 (35°)
pole-mounted	vertical	POLE	–

Assessing mechanical safety



Mechanical safety of the rigging system

Before any installation, always model the system in Soundvision and check the **Mechanical Data** section for any stress warning or stability warning.

In order to assess the actual safety of any array configuration before implementation, refer to the following warnings:



Rated working load limit (WLL) is not enough

The rated WLL is an indication of the element resistance to tensile stress. For complex mechanical systems such as loudspeaker arrays, WLLs cannot be used per se to determine the maximum number of enclosures within an array or to assess the safety of a specific array configuration.

Mechanical modeling with Soundvision

The working load applied to each linking point, along with the corresponding safety factor, will depend on numerous variables linked to the composition of the array (type and number of enclosures, splay angles) and the implementation of the flying or stacking structure (number and location of flying points, site angle). This cannot be determined without the complex mechanical modeling and calculation offered by Soundvision.

Assessing the safety with Soundvision

The overall safety factor of a specific mechanical configuration always corresponds to the lowest safety factor among all the linking points. Always model the system configuration with the Soundvision software and check the **Mechanical Data** section to identify the weakest link and its corresponding working load. By default, a stress warning will appear when the mechanical safety goes beyond the recommended safety level.

Safety of ground-stacked arrays in Soundvision

For ground-stacked arrays, a distinct stability warning is implemented in Soundvision. It indicates a tipping hazard when the array is not secured to the ground, stage or platform. It is the user's responsibility to secure the array and to ignore the warning.

Additional safety for flown arrays

When flying an array, use available holes to implement a secondary safety.

Considerations must be given to unusual conditions

Soundvision calculations are based on usual environmental conditions. A higher safety factor is recommended with factors such as extreme high or low temperatures, strong wind, prolonged exposition to salt water, etc. Always consult a rigging specialist to adopt safety practices adapted to such a situation.

Loudspeaker configurations

X8i point source

Deployed as a standalone point source, an X8i system operates over the nominal bandwidth of the X8i enclosure for short throw applications.

Two factory presets are available:

- The [X8i_40] preset extends the bandwidth in the low end, for full-range sound reproduction.
- The [X8i] preset offers a higher SPL output for vocal reinforcement or to be combined with a low-frequency element.

The X8i enclosure is driven by the LA2Xi / LA4X / LA7.16i / LA12X amplified controllers.



Reduced maximum SPL or drive capacity with LA2Xi: refer to the **LA2Xi owner's manual**.

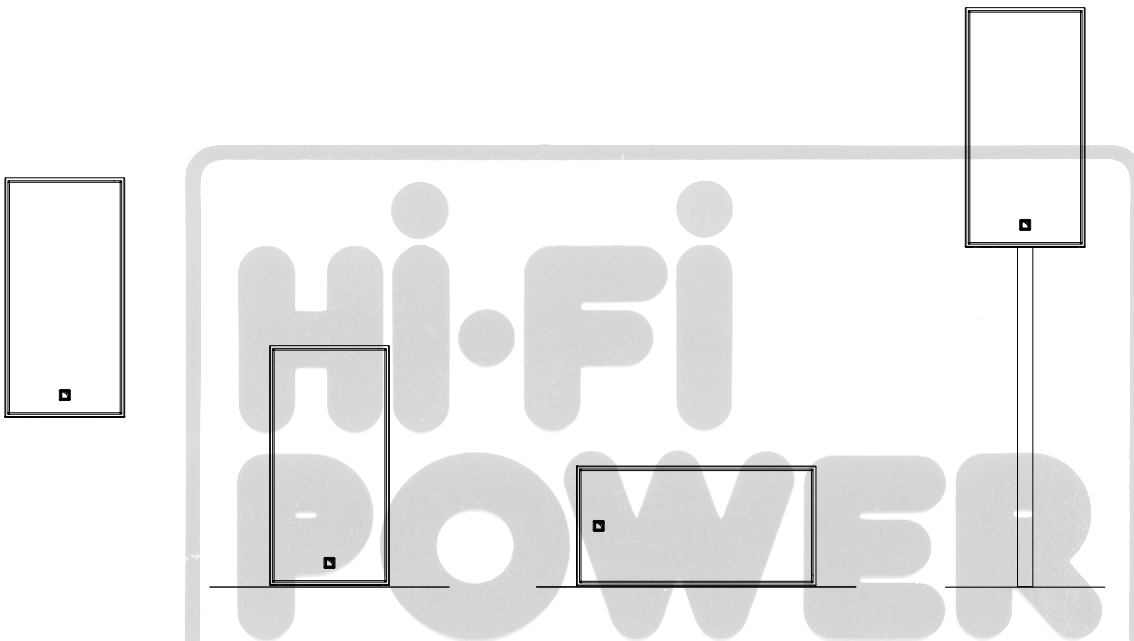

Preset	[X8i_40]	[X8i]
Usable bandwidth (-10 dB)	43 Hz - 20 kHz	67 Hz - 20 kHz
Maximum SPL	123 dB	129 dB

X8i point source with low-frequency element

Deployed as a point source with SB10i(r), Syva Sub, or KS21(i) subwoofers, X8i system is extended in the low end and the LF contour is reinforced.



Gain structure

X8i and SB10i(r) provide 4 dB of headroom.

Syva Sub and KS21(i) provide 8 dB of headroom.

Refer to the **Preset Guide** for more information.

configuration	subwoofer upper frequency limit	presets		
		SB10i(r)	Syva Sub	KS21(i)
coupled	100 Hz	[SB10_100]	[SYVA SUB_100]	[KS21_100]
separated	60 Hz	[SB10_60]	–	[KS21_60]

X8i, SB10i(r), Syva Sub, and KS21(i) are driven by LA2Xi / LA4X / LA7.16i / LA12X.

i Reduced maximum SPL or drive capacity with LA2Xi: refer to the **LA2Xi owner's manual**.

X8i with SB10i(r)

Coupled

With SB10i(r) and the [SB10_100] preset, the bandwidth of the X8i system is extended down to 27 Hz and the system contour is reinforced.

The [X8i] preset is recommended for X8i in this configuration.

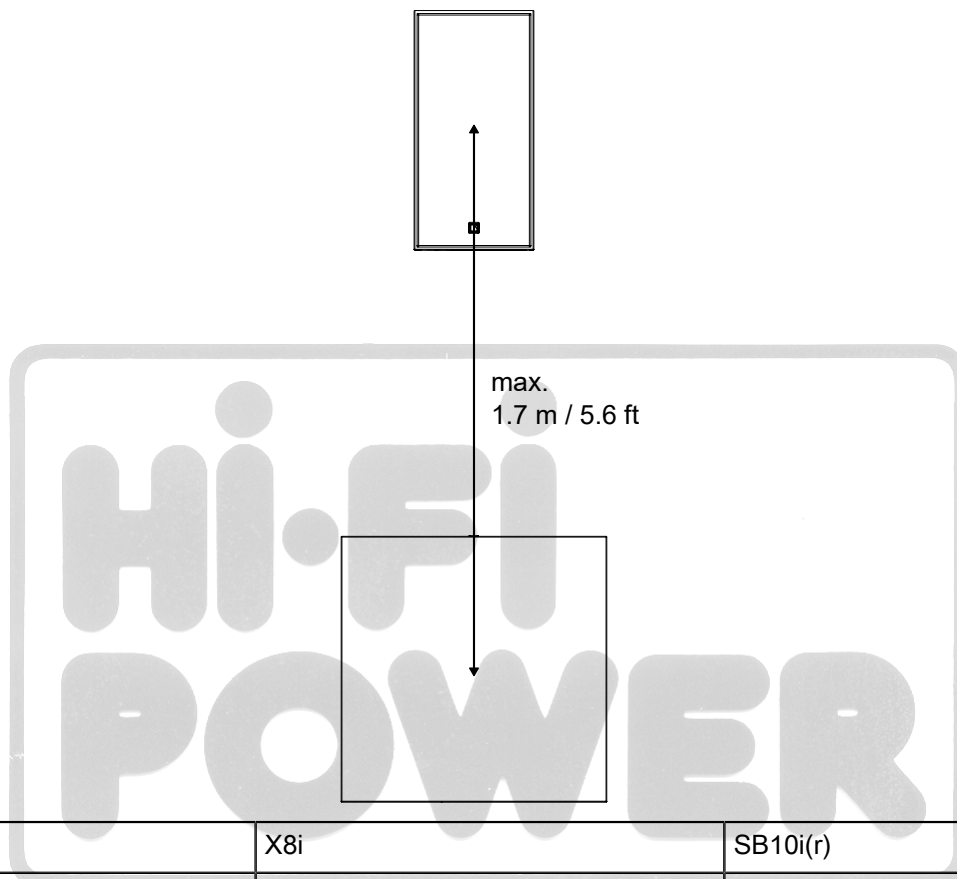

Enclosure	X8i	SB10i(r)
Preset	[X8i]	[SB10_100]
Recommended ratio	1 X8i : 1 SB10i(r)	
Usable bandwidth (-10 dB)	27 Hz - 20 kHz	
System contour (peak low-end SPL)	+6 dB at 1 kHz with [X8i]	

i Contour value takes into account the effect of the wall and floor on the contour.

! **Delay values**
Do not forget to add the pre-alignment and geometric delays depending on the configuration.

Pre-alignment delays

presets	pre-alignment delay values and polarity settings	
[X8i] + [SB10_100]	X8i = 0 ms <input type="checkbox"/>	SB10i = 0.5 ms <input type="checkbox"/>

Separated

With SB10i(r) and the [SB10_60] preset, the bandwidth of the X8i is extended down to 25 Hz and the system contour is reinforced.

The [X8i_40] preset is recommended for X8i in this configuration.

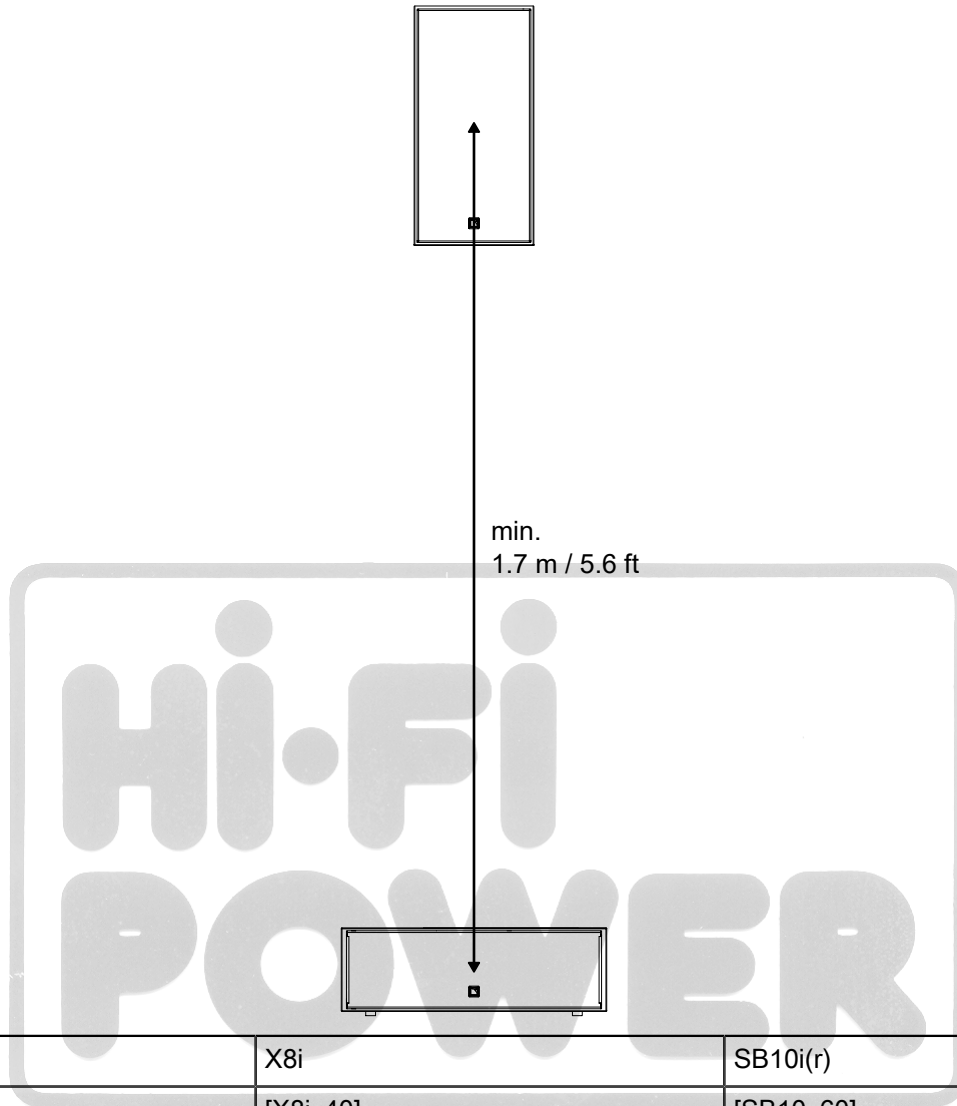

Enclosure	X8i	SB10i(r)
Preset	[X8i_40]	[SB10_60]
Recommended ratio	1 X8i : 1 SB10i(r)	
Usable bandwidth (-10 dB)	25 Hz - 20 kHz	
System contour (peak low-end SPL)	+8 dB at 1 kHz with [X8i_40]	



Contour value takes into account the effect of the wall and floor on the contour.



Delay values

Do not forget to add the pre-alignment and geometric delays depending on the configuration.

Pre-alignment delays

presets	pre-alignment delay values and polarity settings	
[X8i_40] + [SB10_60]	X8i = 0 ms <input style="float: right;" type="button" value="+"/>	SB10i = 3 ms <input style="float: right;" type="button" value="+"/>

X8i with Syva Sub

Coupled

With Syva Sub and the [SYVA SUB_100] preset, the bandwidth of the X8i system is extended down to 27 Hz and the system contour is reinforced.

The [X8i] preset is recommended for X8i in this configuration.

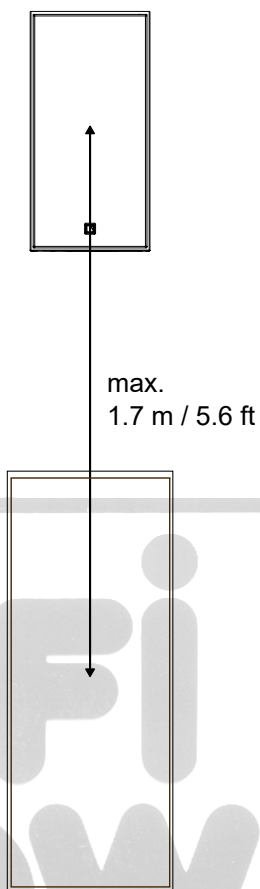

Enclosure	X8i	Syva Sub
Preset	[X8i]	[SYVA SUB_100]
Recommended ratio	1 X8i : 1 Syva Sub	
Usable bandwidth (-10 dB)	27 Hz - 20 kHz	
System contour (peak low-end SPL)	+6 dB at 1 kHz with [X8i]	

i Contour value takes into account the effect of the wall and floor on the contour.

! **Delay values**
Do not forget to add the pre-alignment and geometric delays depending on the configuration.

Pre-alignment delays

presets	pre-alignment delay values and polarity settings	
[X8i] + [SYVA SUB_100]	X8i = 0 ms <input style="background-color: #cccccc;" type="button" value="+"/>	Syva Sub = 0 ms <input style="background-color: #cc0000;" type="button" value="-"/>

X8i with KS21(i)

Coupled

With KS21(i) and the [KS21_100] preset, the bandwidth of the X8i system is extended down to 31 Hz and the system contour is reinforced.

The [X8i] preset is recommended for X8i in this configuration.

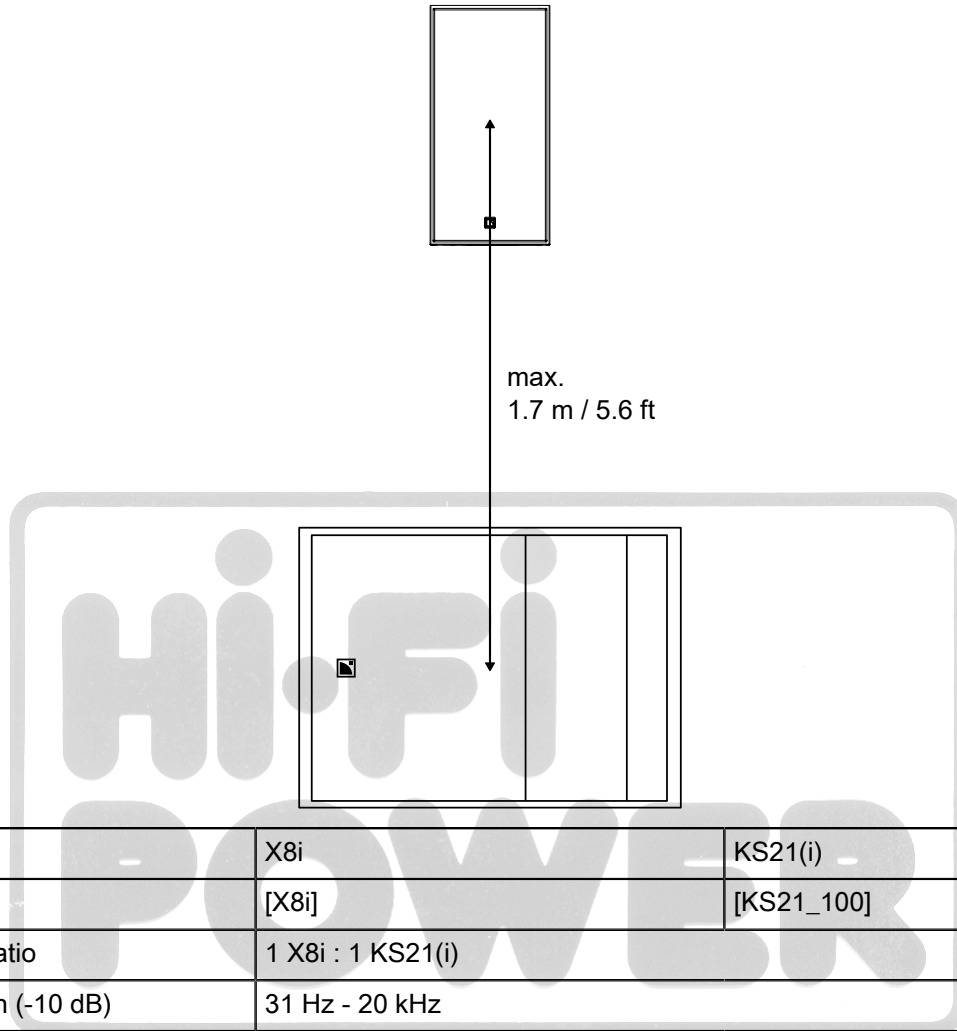

Enclosure	X8i	KS21(i)
Preset	[X8i]	[KS21_100]
Recommended ratio	1 X8i : 1 KS21(i)	
Usable bandwidth (-10 dB)	31 Hz - 20 kHz	
System contour (peak low-end SPL)	+15 dB at 1 kHz with [X8i]	



Contour value takes into account the effect of the wall and floor on the contour.



Do not forget to add the geometric delays depending on the configuration.



No pre-alignment delay values are required for this configuration.

Separated

With KS21(i) and the [KS21_60] preset, the bandwidth of the X8i is extended down to 29 Hz and the system contour is reinforced.

The [X8i_40] preset is recommended for X8i in this configuration.

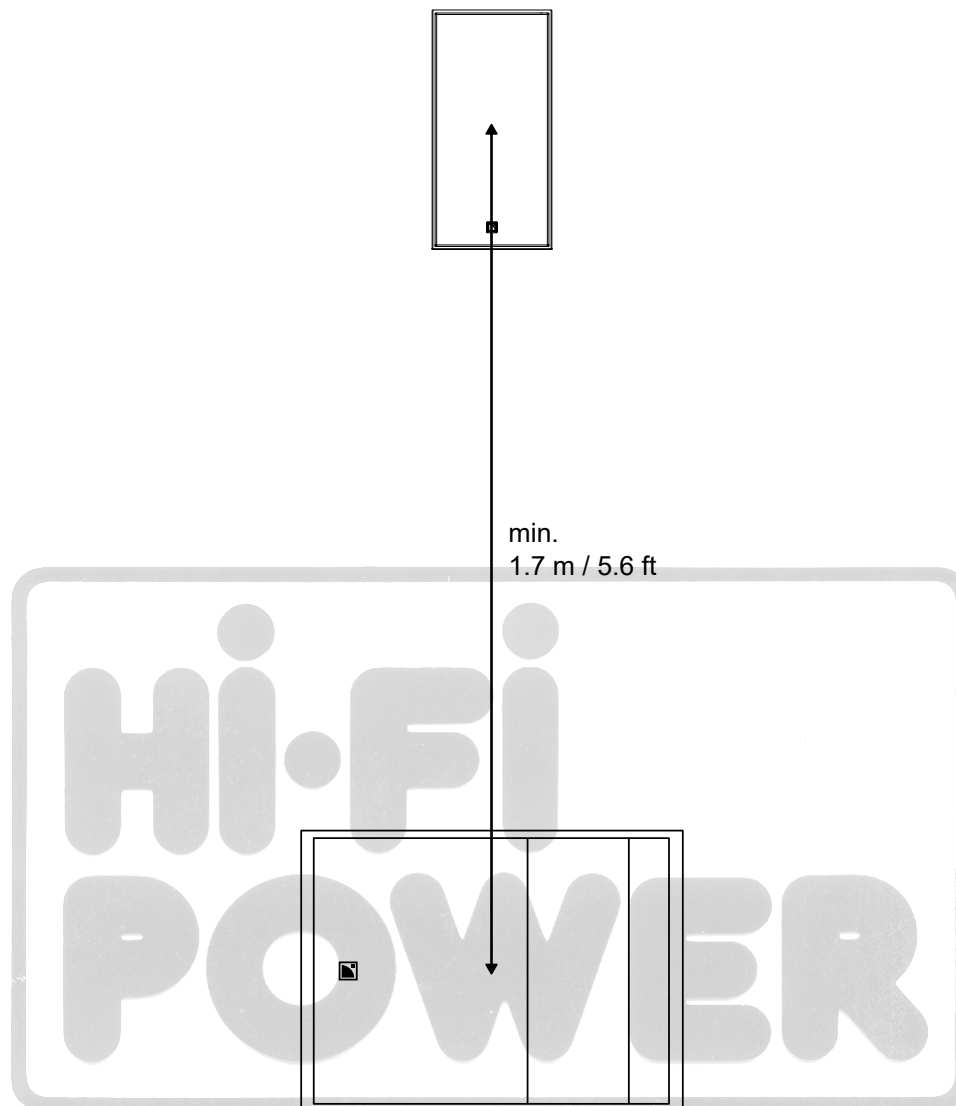

Enclosure	X8i	KS21(i)
Preset	[X8i_40]	[KS21_60]
Recommended ratio	1 X8i : 1 KS21(i)	
Usable bandwidth (-10 dB)	29 Hz - 20 kHz	
System contour (peak low-end SPL)	+20 dB at 1 kHz with [X8i_40]	

i Contour value takes into account the effect of the wall and floor on the contour.

! **Delay values**
Do not forget to add the pre-alignment and geometric delays depending on the configuration.

Pre-alignment delays

presets	pre-alignment delay values and polarity settings	
[X8i_40] + [KS21_60]	X8i = 4.8 ms <input type="checkbox"/>	KS21 = 0 ms <input type="checkbox"/>

X8i stage monitor

Deployed as a stage monitor, an X8i system operates over the nominal bandwidth of the X8i enclosure.

The [X8i_MO] preset delivers a reference frequency response in stage monitoring applications.

The X8i enclosure is driven by the LA2Xi / LA4X / LA7.16i / LA12X amplified controllers.



Preset	[X8i_MO]
Usable bandwidth (-10 dB)	59 Hz - 20 kHz

Low-latency preset

A low-latency preset is available for the X8i enclosure used as a monitor ([X8i_MO]). It reduces latency from 3.84 ms down to 1.18 ms (LA7.16i) and 0.84 ms (LA2Xi / LA4X / LA12X).

To combine the monitor with a subwoofer:

- on 4-channel amplified controllers, create a custom low-latency preset
- on 16-channel amplified controllers, select the low-latency (*_MO) preset for the subwoofer

Refer to the **LA Network Manager Help** for more information.

Paired X8i monitors with LFC

The Low Frequency Contour (LFC) tool implemented in LA Network Manager can compensate for coupling effects between closely operating monitors. LFC allows to adjust the frequency response curve to obtain the desired low frequency contour.

For paired X8i monitors, enter the following parameters to obtain the reference response curve of a single enclosure:

LF Contour		N/A
FREQ/RATIO	180	
GAIN	-3.0	

For more information about LFC, refer to the **LA Network Manager Help** (section: Group Control Panel) and to the **Array Morphing** white paper, available on www.l-acoustics.com.

Rigging procedures



X8i mechanical configurations overview

Use the following tables to choose the appropriate mechanical configuration based on the deployment parameters. Each configuration links to the corresponding procedure.

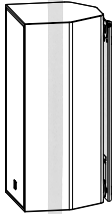
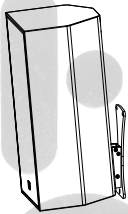
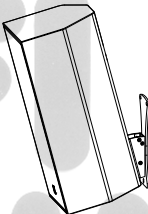
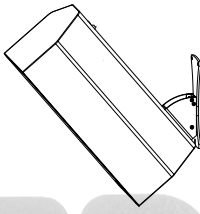

⚠ Risk of injury or product damage
 This manual describes all allowed mechanical configurations with X8i and its accessories.
 Do not attempt to use these products outside of their intended use.

i Deployment parameter definitions
Site angle ("tilt"): Physical deployment parameter that refers to the position of the source as the elevation angle in the vertical dimension.
Azimuth angle ("pan"): Physical deployment parameter that refers to the position of the source as the off-axis angle in the horizontal dimension.

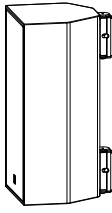
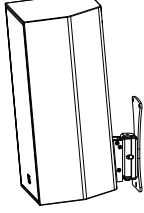
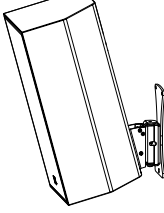
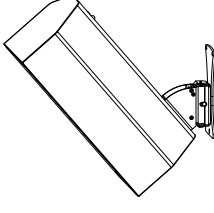
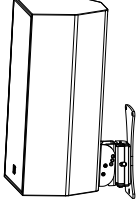

X8i wall-mounted vertically

with pan?	site angle				
	0°	-5°	-15°	-40°	0° to -40°
no	X8i-onCW (p.49) 	TILT-SUPPORT + TILT5 (p.59) 	TILT-SUPPORT + TILT15 (p.59) 	TILT-SUPPORT + TILT40 (p.59) 	TILT-SUPPORT + TILT (p.65) 
	WALLx2 (p.54) 				
yes	PANx2 (p.71) 	TILT-SUPPORT + PAN + TILT5 (p.76) 	TILT-SUPPORT + PAN + TILT15 (p.76) 	TILT-SUPPORT + PAN + TILT40 (p.76) 	TILT-SUPPORT + PAN + TILT (p.83) 

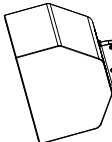
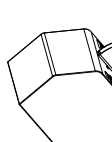
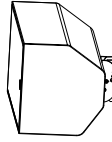
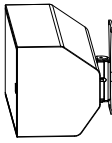
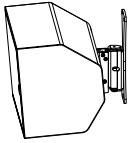
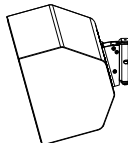
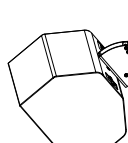
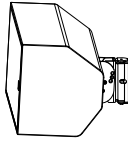
X8i wall-mounted horizontally

with pan?	site angle				
	0°	-5°	-15°	-40°	0° to -40°
no	<p>TILT-SUPPORT + WALL (p.91)</p> 	<p>TILT-SUPPORT + TILT5 (p.96)</p> 	<p>TILT-SUPPORT + TILT15 (p.96)</p> 	<p>TILT-SUPPORT + TILT40 (p.96)</p> 	<p>TILT-SUPPORT + TILT (p.101)</p> 
yes	<p>TILT-SUPPORT + PAN (p.108)</p> 	<p>TILT-SUPPORT + PAN + TILT5 (p.113)</p> 	<p>TILT-SUPPORT + PAN + TILT15 (p.113)</p> 	<p>TILT-SUPPORT + PAN + TILT40 (p.113)</p> 	<p>TILT-SUPPORT + PAN + TILT (p.121)</p> 

X8i ceiling-mounted vertically

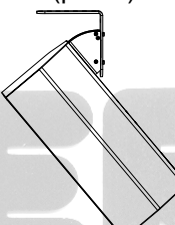
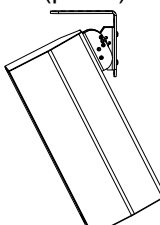
site angle				
0°	-5°	-15°	-40°	0° to -40°
<p>VBAR (p.130)</p> 	<p>VBAR + TILT5 (p.137)</p> 	<p>VBAR + TILT15 (p.137)</p> 	<p>VBAR + TILT40 (p.137)</p> 	<p>VBAR + TILT (p.142)</p> 

X8i ceiling-mounted horizontally

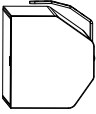
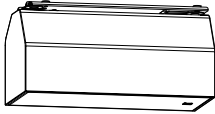
site angle	
0° to -35°	90° (downward-facing)
<p>X8i-HBAR (p.147)</p> 	<p>X8i-onCW (p.155)</p> 

X8i truss-mounted or suspended by a threaded rod

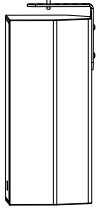
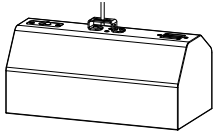
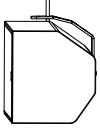
orientation	site angle	
	9° to -17°	90° (downward-facing)
Vertical	<p>VBAR (p.130)</p> 	<p>CEILING-PENDANT (p.160)</p> 
Horizontal	9° to -40°	
	<p>X8i-HBAR (p.147)</p> 	

X8i ground-stacked

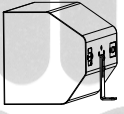
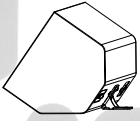
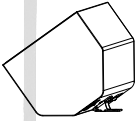
orientation	site angle		
	0°	35°	55°
Vertical	no rigging accessory	—	—
Horizontal	<p>GROUND (p.162)</p> 	<p>GROUND35 (p.162)</p> 	<p>GROUND55 (p.162)</p> 

X8i pole-mounted

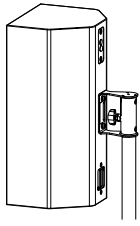

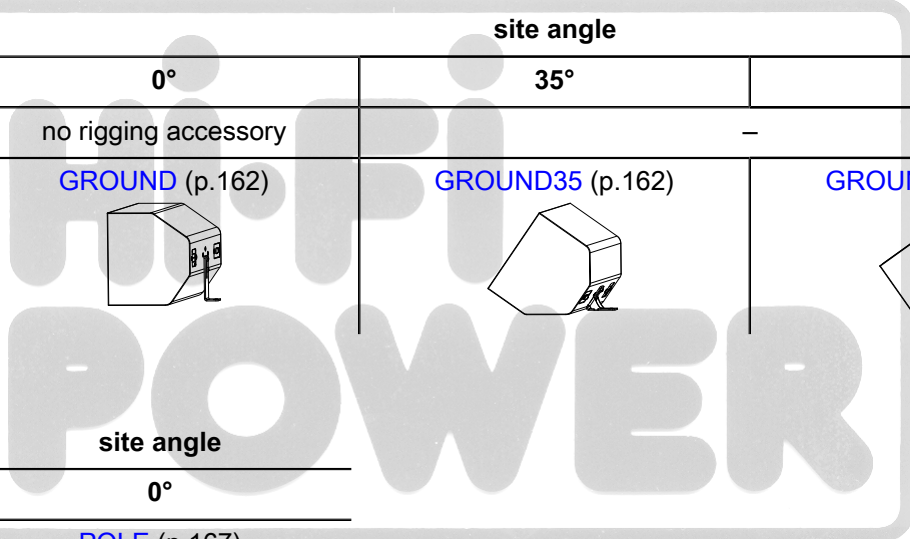

orientation	site angle
	0°
Vertical	<p>POLE (p.167)</p> 

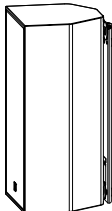
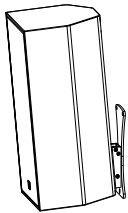
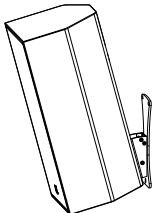
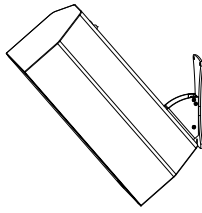

Wall-mounting

Wall-mounting X8i vertically

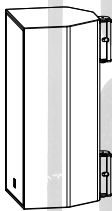
Overview

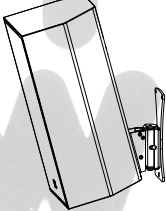
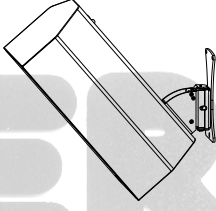
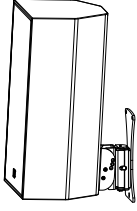
with pan?	site angle				
	0°	-5°	-15°	-40°	0° to -40°
no	<p>X8i-onCW (p.49)</p> 	<p>TILT-SUPPORT + TILT5 (p.59)</p> 	<p>TILT-SUPPORT + TILT15 (p.59)</p> 	<p>TILT-SUPPORT + TILT40 (p.59)</p> 	<p>TILT-SUPPORT + TILT (p.65)</p> 
	<p>WALLx2 (p.54)</p> 				
yes	<p>PANx2 (p.71)</p> 	<p>TILT-SUPPORT + PAN + TILT5 (p.76)</p> 	<p>TILT-SUPPORT + PAN + TILT15 (p.76)</p> 	<p>TILT-SUPPORT + PAN + TILT40 (p.76)</p> 	<p>TILT-SUPPORT + PAN + TILT (p.83)</p> 

Wall-mounting X8i vertically with X8i-onCW

Type of deployment	wall-mounting
Rigging accessories	X8i-onCW
Additional material	4 compatible screws and anchors
Tools	torque screwdriver
	T20 Torx bit
	T30 Torx bit
Min. number of operators	1

! **Secondary safety for flown, wall-mounted, or ceiling-mounted enclosures**
Use one insert at the back of the enclosure to implement a secondary safety.

! **Risk of crushing injury**
Ensure that the wall or ceiling can support the load of the product.
It is recommended to mount only on solid structures. If mounting on a hollow structure (such as a wall cavity), place anchoring points on the framework (wall studs, ceiling joists), or reinforce the mounting area.
Select screws and anchors applicable to the wall or ceiling properties and to the load of the product. Prevent screws from loosening over time, using for example thread locker or lock washers.

Specifications for screws and anchors

deployment	accessory	ultimate tensile load per screw (daN)	ultimate shear load per screw (daN)	screws quantity	mounting hole size	specific constraints
wall-mounting	X8i-onCW	6	5	4	Ø 6.4 mm / 0.25 in (slotted)	total thickness with spacers: 13.10 mm / 0.51 in

! SPCON cannot be used in this configuration.

Screws and fasteners

from X8i-onCW

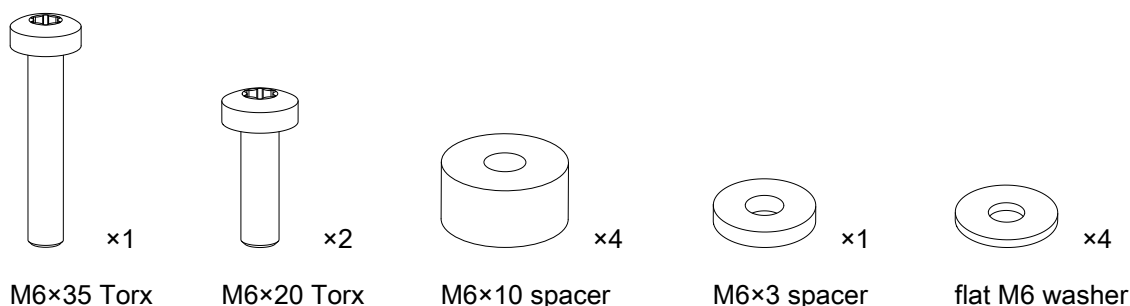

Assembly

About this task

! For this configuration, the speaker cable must be run inside the wall or ceiling.

Prerequisite

Place X8i on its front face on a clean flat surface.

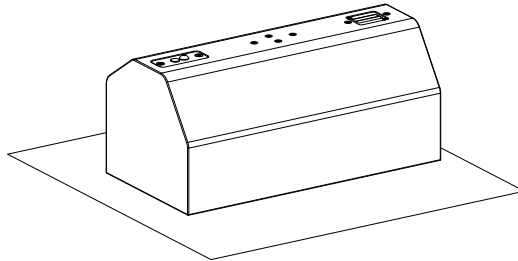

Make sure that the X8i-onCW safety screws are present and loosened.

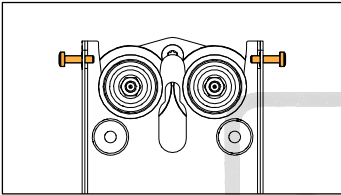

Procedure

! Make sure to leave enough space between the walls and the sides of the rigging element to access the screw(s) when the enclosure is mounted.

1. Drill holes in the wall for the anchors and for the cable exit(s).

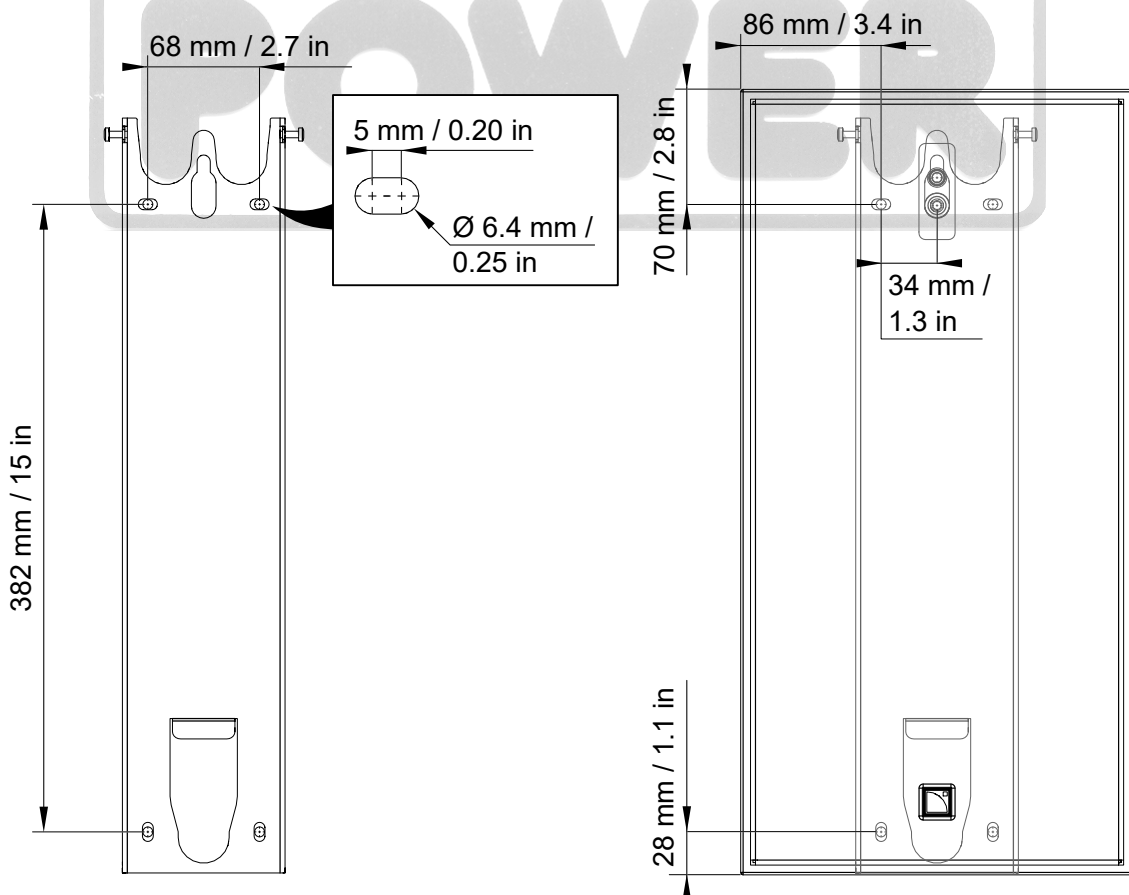

2. Run the speaker cable inside the wall or ceiling.
3. Secure the surface-mounting plate to the wall, using the four M6×10 spacers.

If the surface is uneven, adjust with the flat M6 washers.

Run the cable through the top hole of the surface-mounting plate.

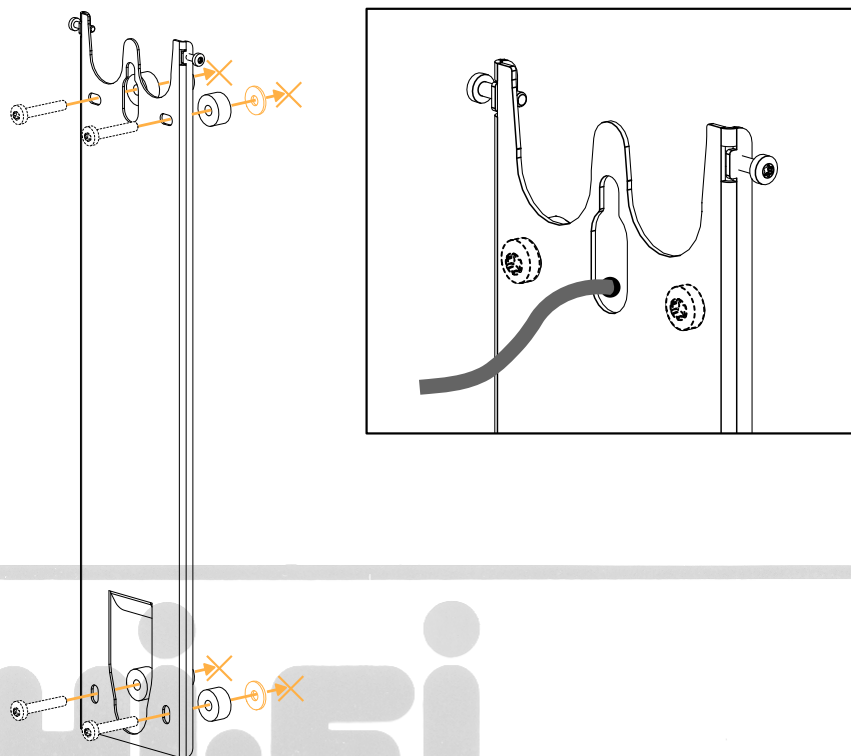

4. Secure the two top silent blocks to X8i:
 - a) Remove the connector sealing plate (if present) or the placeholder screws.
 - b) Run the cable through the enclosure-mounting plate and through the connector sealing plate.
 - c) Connect the cable to the X8i terminal block. Refer to [Cabling X8i](#) (p.171).
 - d) Secure the enclosure-mounting plate and the connector sealing plate to X8i.

Use the two M6×20 Torx screws.

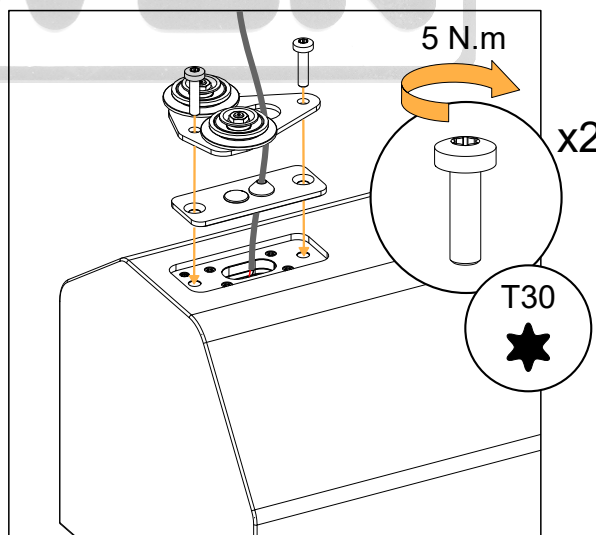
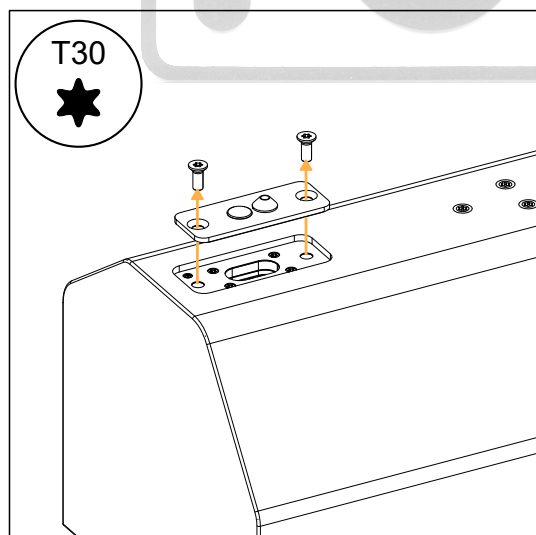

5. Secure the bottom silent block to X8i:

- a) Remove the placeholder screw at the bottom of X8i.
- b) Secure the silent block and the M6×3 spacer at the bottom of the enclosure.

Use the M6×30 Torx screw.

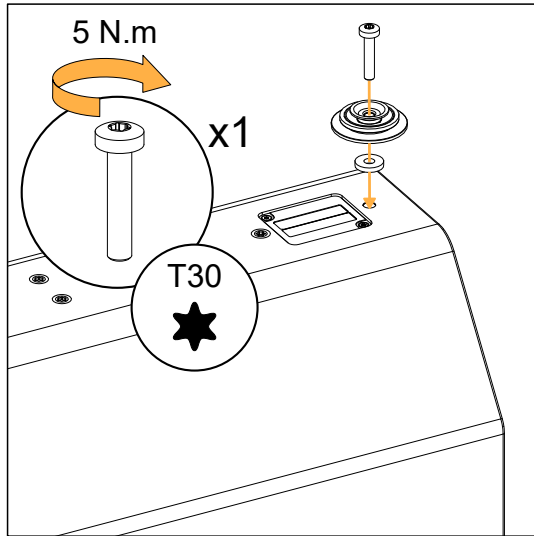
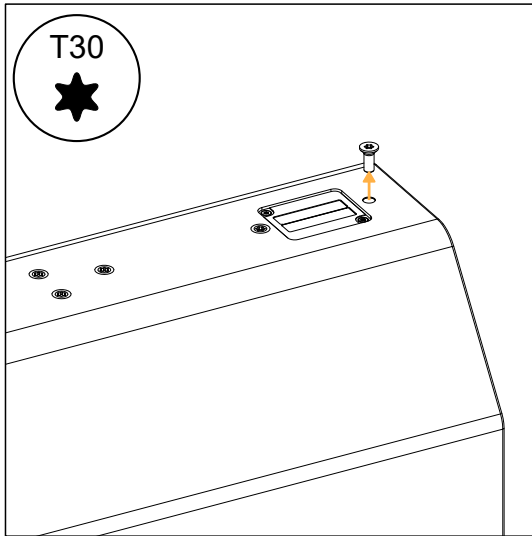

Risk of crushing injury

This step requires two operators.

6. Mount X8i on the wall:

- a) Align the silent blocks with the surface-mounting plate cutouts.
- b) Push the assembly towards the bottom of X8i.

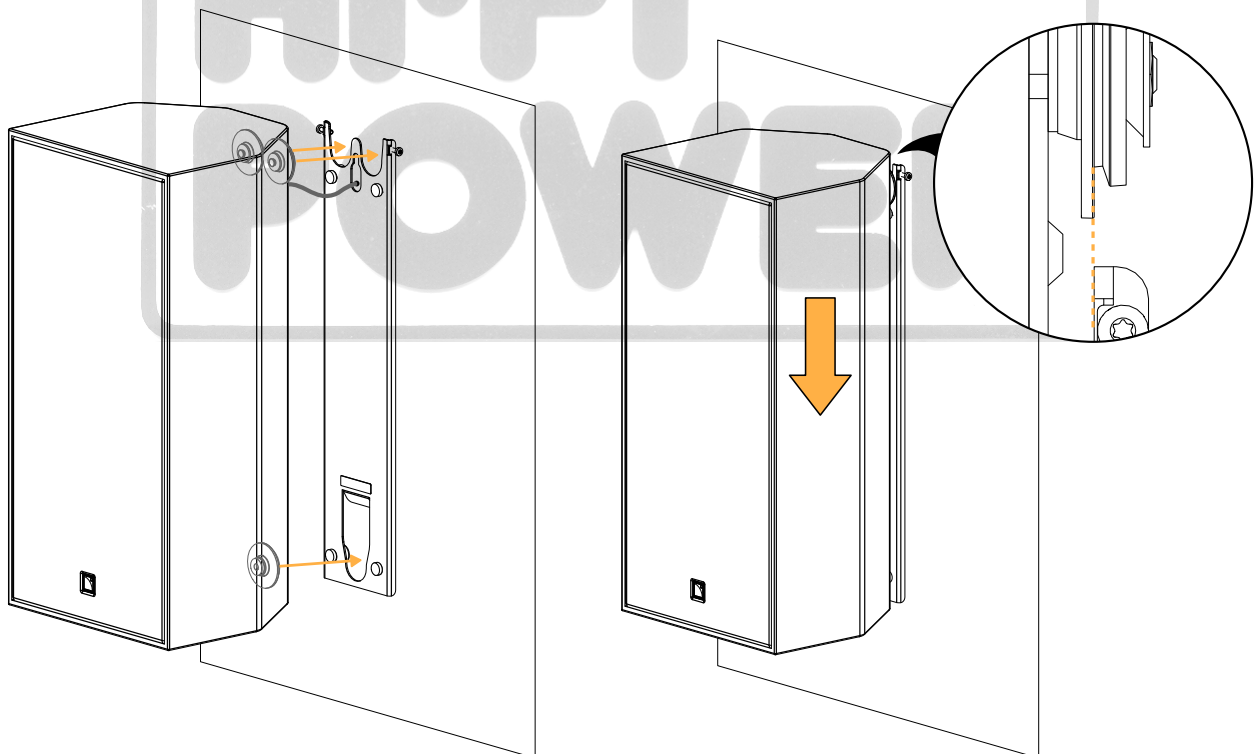

7. Tighten the safety screws on both sides and make sure the assembly is stable.

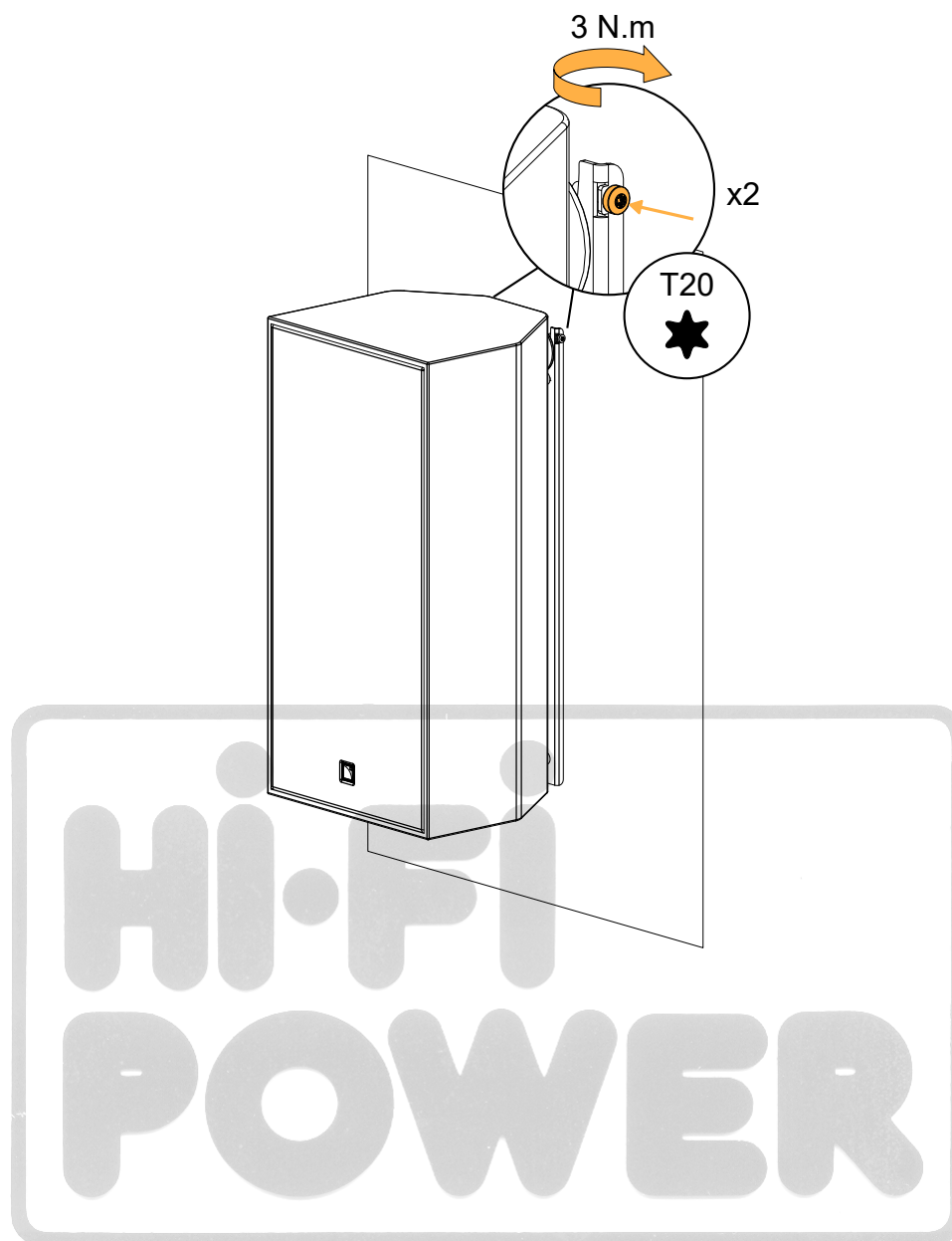

Wall-mounting X8i vertically with WALLx2

Type of deployment	wall-mounting
Rigging accessories	WALLx2
Additional material	4 compatible screws and anchors
Tools	torque screwdriver
	T20 Torx bit
	T30 Torx bit
Min. number of operators	1

**Secondary safety for flown, wall-mounted, or ceiling-mounted enclosures**

Use one insert at the back of the enclosure to implement a secondary safety.

**Risk of crushing injury**

Ensure that the wall or ceiling can support the load of the product.

It is recommended to mount only on solid structures. If mounting on a hollow structure (such as a wall cavity), place anchoring points on the framework (wall studs, ceiling joists), or reinforce the mounting area.

Select screws and anchors applicable to the wall or ceiling properties and to the load of the product. Prevent screws from loosening over time, using for example thread locker or lock washers.

Specifications for screws and anchors

deployment	accessory	ultimate tensile load per screw (daN)	ultimate shear load per screw (daN)	screws quantity	mounting hole size	specific constraints
wall-mounting	WALLx2	6	5	4	Ø 5.2 mm / 0.20 in	maximum screw head size: Ø 11 mm / 0.43 in

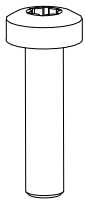

SPCON cannot be used in this configuration.

Screws and fasteners**from WALLx2**

x4

M6×25 Torx



x4

M5 tapered spacer

Assembly

About this task

! For this configuration, the speaker cable must be run inside the wall.

Prerequisite

Place X8i on its front face on a clean flat surface.

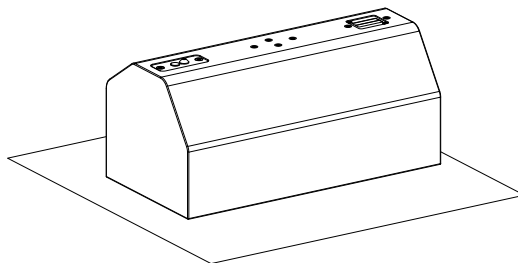

Make sure that the WALLx2 safety screws are present and loosened.

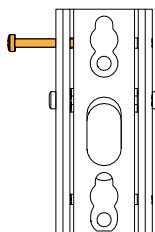

Procedure

! Make sure to leave enough space between the walls and the sides of the rigging element to access the screw(s) when the enclosure is mounted.

1. Drill holes in the wall for the anchors and for the cable exit.

Use the provided drilling template.

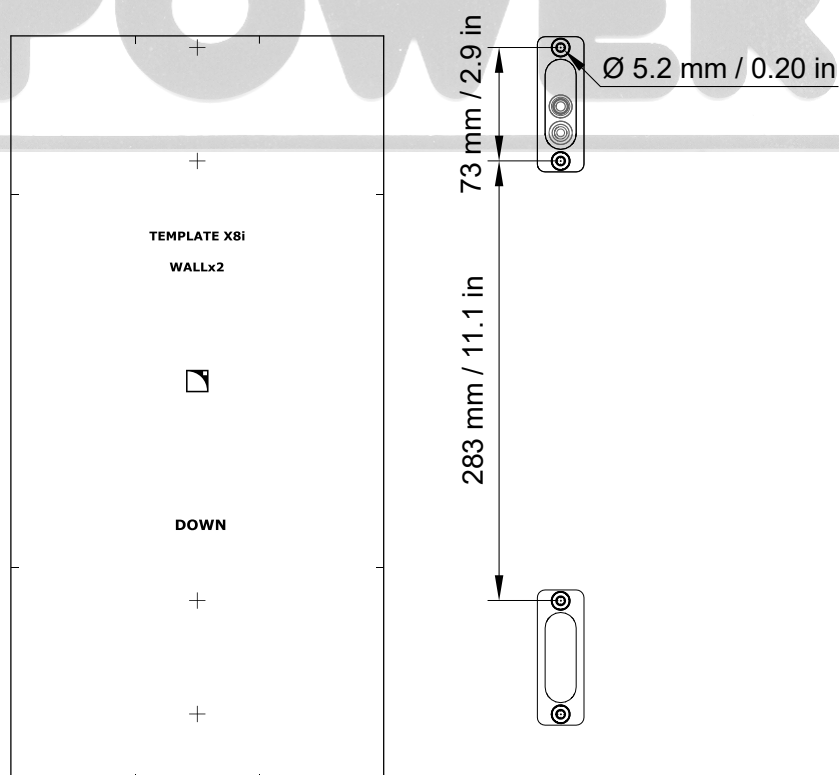

2. Run the speaker cable inside the wall.

3. Secure the two wall-mounting plates to the wall with the four tapered spacers.

The gaskets are facing away from the wall.

Run the speaker cable through the top wall-mounting plate.

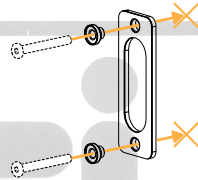
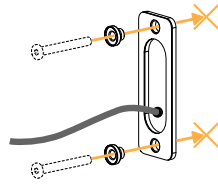

4. Secure the top WALLx2 part to X8i:

- Remove the connector sealing plate (if present) or the placeholder screws.
- Run the cable through the WALLx2 part and through the connector sealing plate.
- Connect the speaker cable to the X8i terminal block. Refer to [Cabling X8i](#) (p.171).
- Secure the WALLx2 part and the connector sealing plate to X8i.

Use two M6×25 Torx screws.

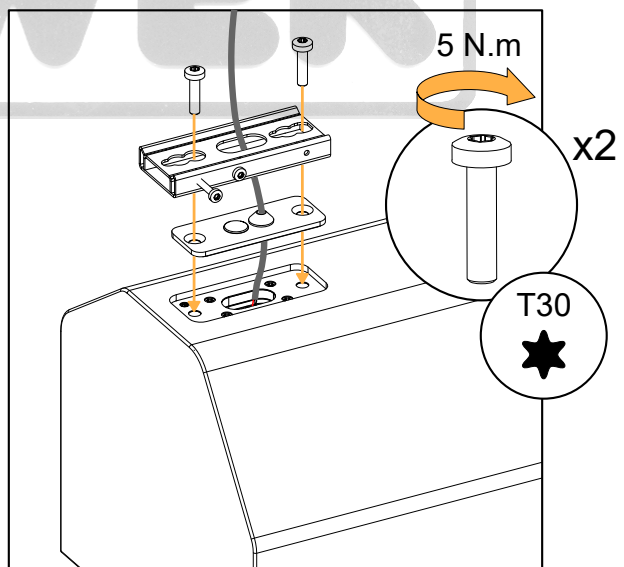
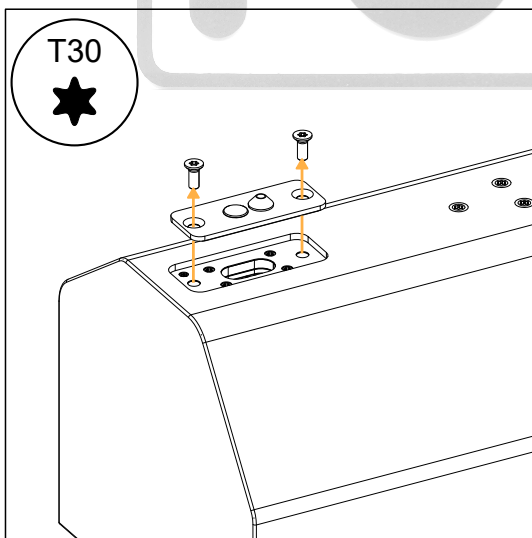

5. Secure the bottom WALLx2 part to X8i:
- Remove the two bottom placeholder screws.
 - Secure the WALLx2 part to X8i.

Use two M6×25 Torx screws.

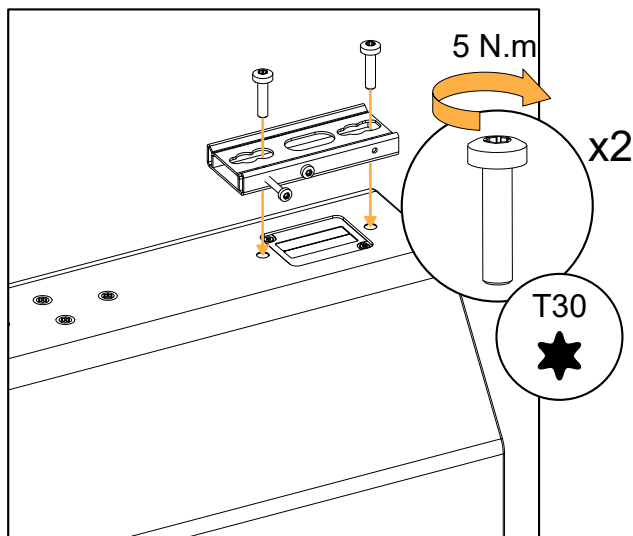
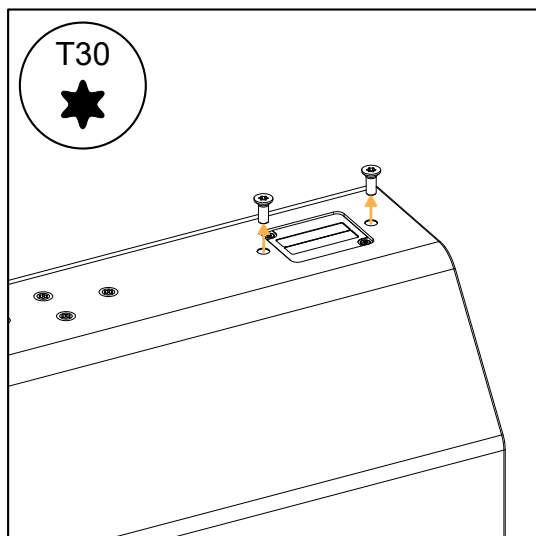

6. Mount X8i on the wall-mounting plates:
- Align the midpoints of the WALLx2 rear cutouts with the tapered spacers.
 - Push X8i downwards.

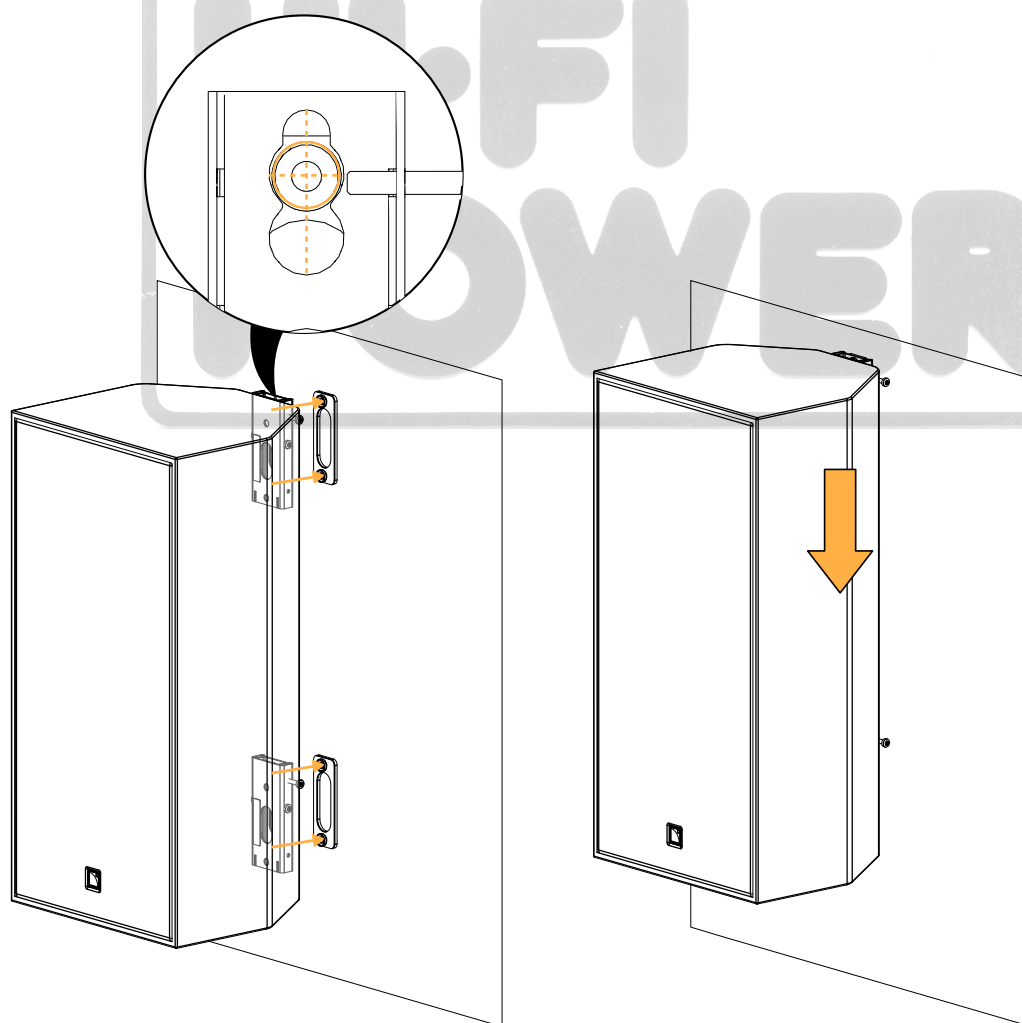

7. Tighten the two safety screws and make sure the assembly is stable.

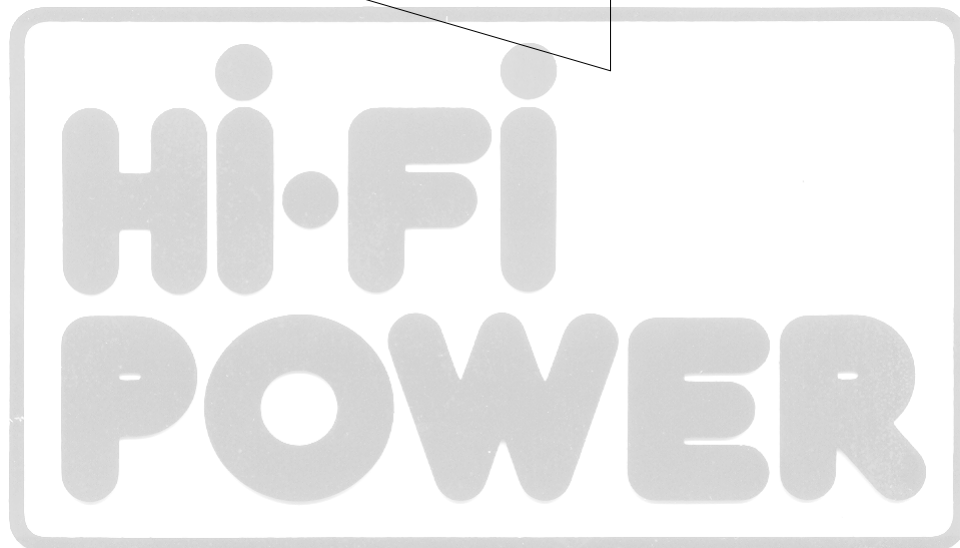
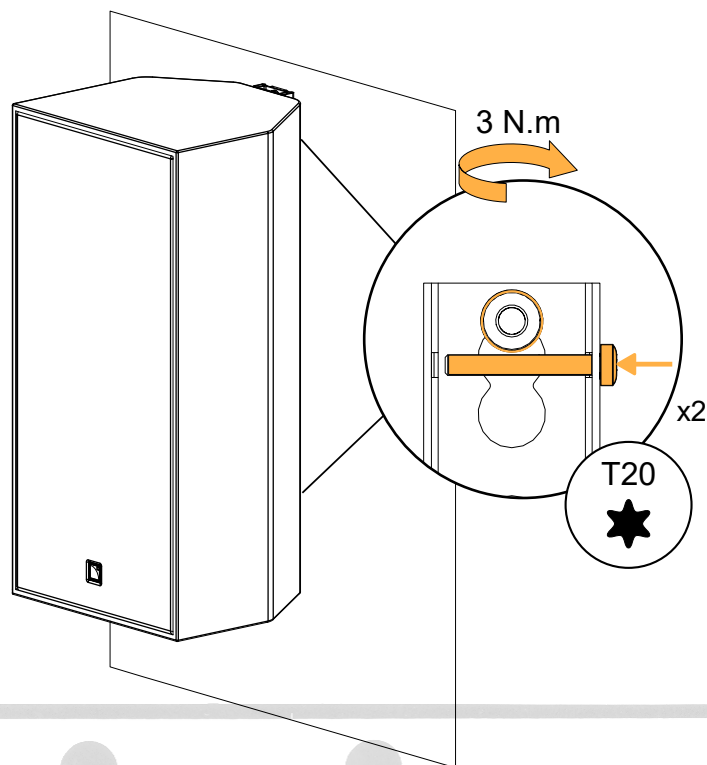

Wall-mounting X8i vertically with TILT5/TILT15/TILT40

Type of deployment	wall-mounting
Rigging accessories	TILT-SUPPORT
	TILT5/TILT15/TILT40
Additional material	3 compatible screws and anchors
Tools	torque screwdriver
	screwdriver extension or angled screwdriver
	T20 Torx bit
	T30 Torx bit
	8 mm wrench or 8 mm hex socket
Min. number of operators	1

! Secondary safety for flown, wall-mounted, or ceiling-mounted enclosures

Use one insert at the back of the enclosure to implement a secondary safety.

! Risk of crushing injury

Ensure that the wall or ceiling can support the load of the product.

It is recommended to mount only on solid structures. If mounting on a hollow structure (such as a wall cavity), place anchoring points on the framework (wall studs, ceiling joists), or reinforce the mounting area.

Select screws and anchors applicable to the wall or ceiling properties and to the load of the product. Prevent screws from loosening over time, using for example thread locker or lock washers.

Specifications for screws and anchors

deployment	accessory	ultimate tensile load per screw (daN)	ultimate shear load per screw (daN)	screws quantity	mounting hole size	specific constraints
wall-mounting	TILT-SUPPORT + any accessory	12	9	3	Ø 6.4 mm / 0.25 in (slotted)	–

! Risk of falling objects

Do not use TILT, TILT5, TILT15, or TILT40 upside-down. These rigging accessories are designed for negative site angles only.

Screws and fasteners**from TILT-SUPPORT**

x2

M5 hex locknut

from TILT5/TILT15/TILT40

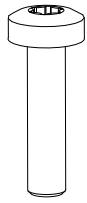

x2

M6x25 Torx



x2

M5 tapered spacer

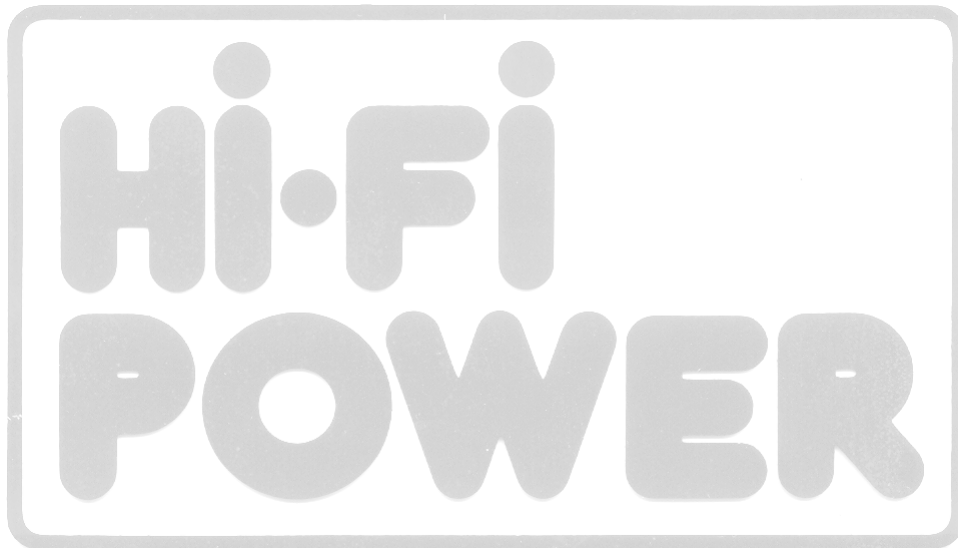

Assembly

About this task

i In this procedure, TILTxx designates the fixed angle accessories TILT5, TILT15, and TILT40.

Prerequisite

Place X8i on its front face on a clean flat surface.

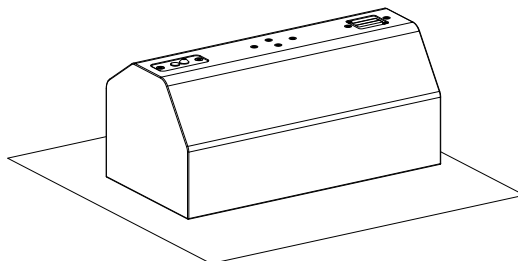

Make sure that the TILTxx safety screw is present and loosened.

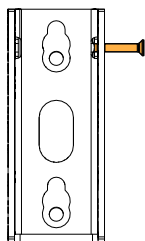

Procedure

! Make sure to leave enough space between the walls and the sides of the rigging element to access the screw(s) when the enclosure is mounted.

1. Drill holes in the wall for TILT-SUPPORT.

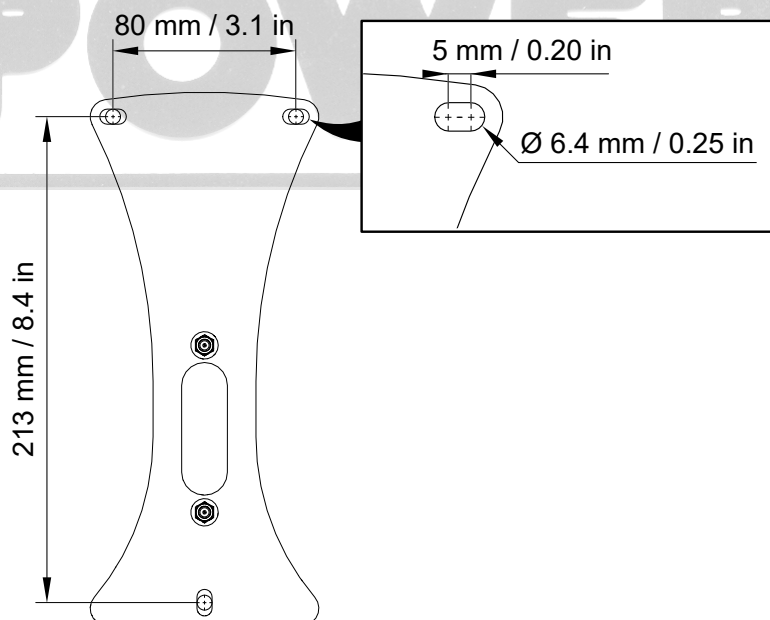

2. Assemble the wall-mounting plate and tapered spacers with TILT-SUPPORT.

Use the two M5 nuts.

The wall-mounting plate gasket is facing away from TILT-SUPPORT.

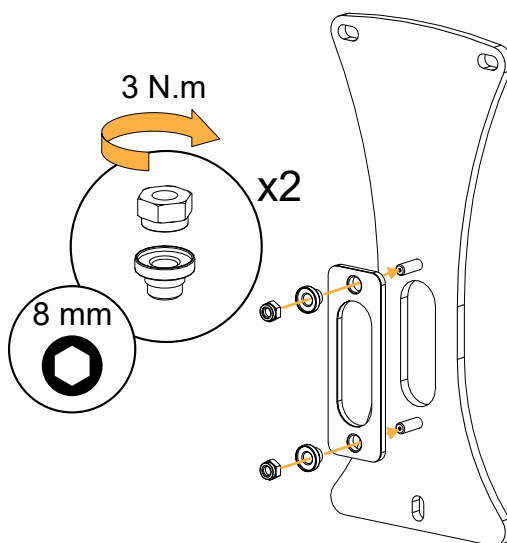

3. Secure TILT-SUPPORT and the wall-mounting plate to the wall.

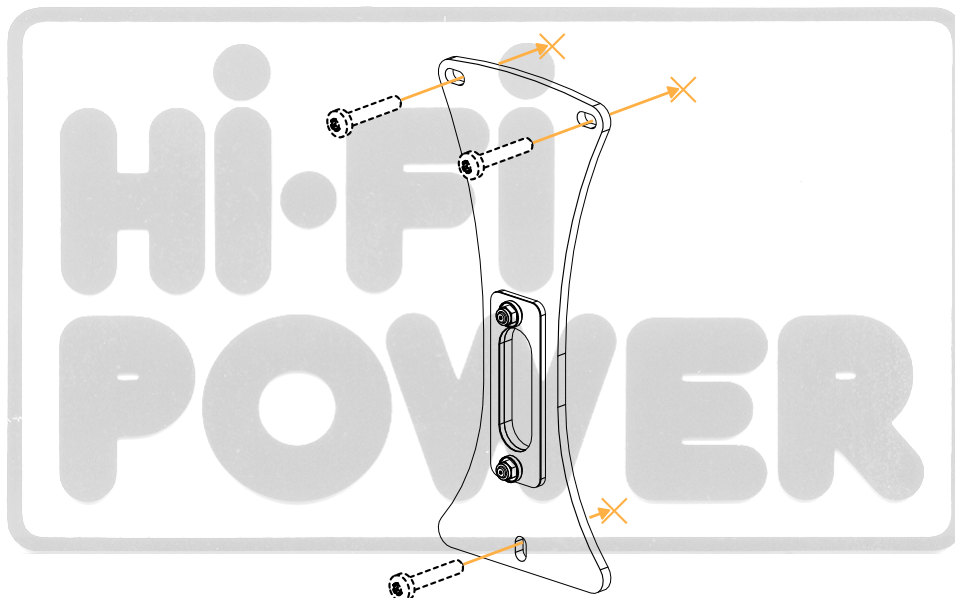

4. Remove the two placeholder screws at the bottom of X8i.

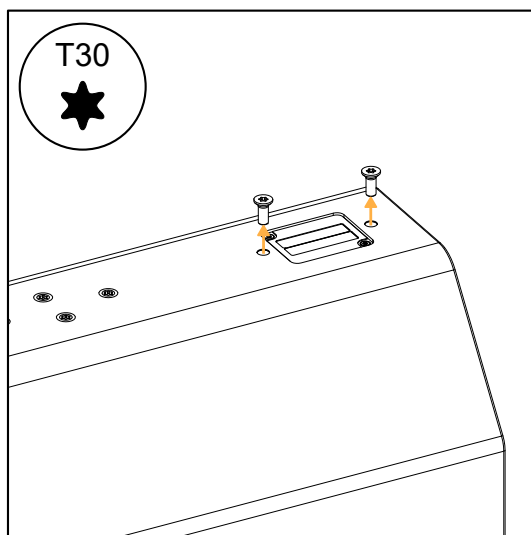

5. Secure TILTxx to X8i.

Use the two M6×25 Torx screws.



If the shank of the screwdriver collides with TILT40, use a screwdriver extension or an angled screwdriver to drive the screws.

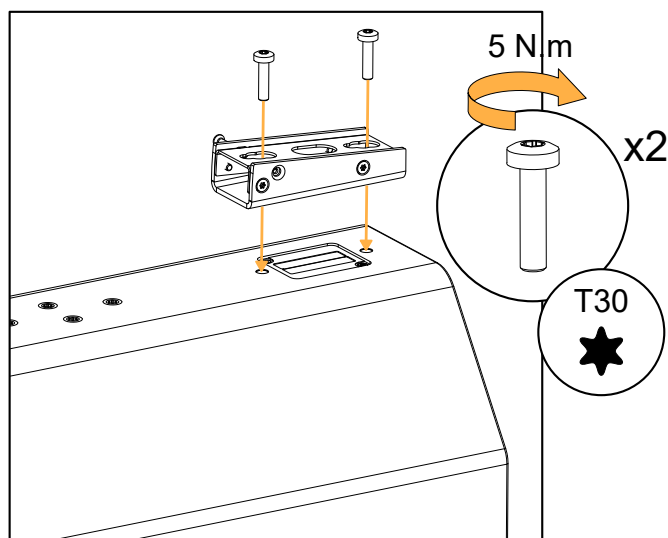

6. Prepare the cabling. Refer to [Cabling X8i](#) (p.171).

7. Mount X8i on the wall-mounting plate:

- a) Align the midpoints of the TILTxx rear cutouts with the tapered spacers.
- b) Push the assembly downwards.

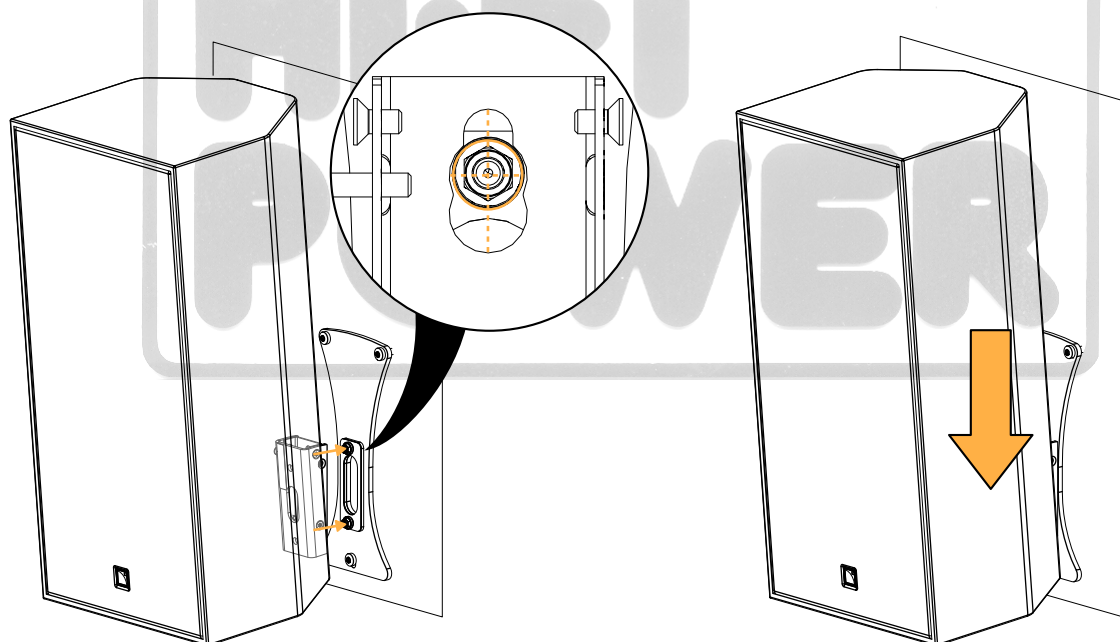

8. Tighten the safety screw and make sure the assembly is stable.

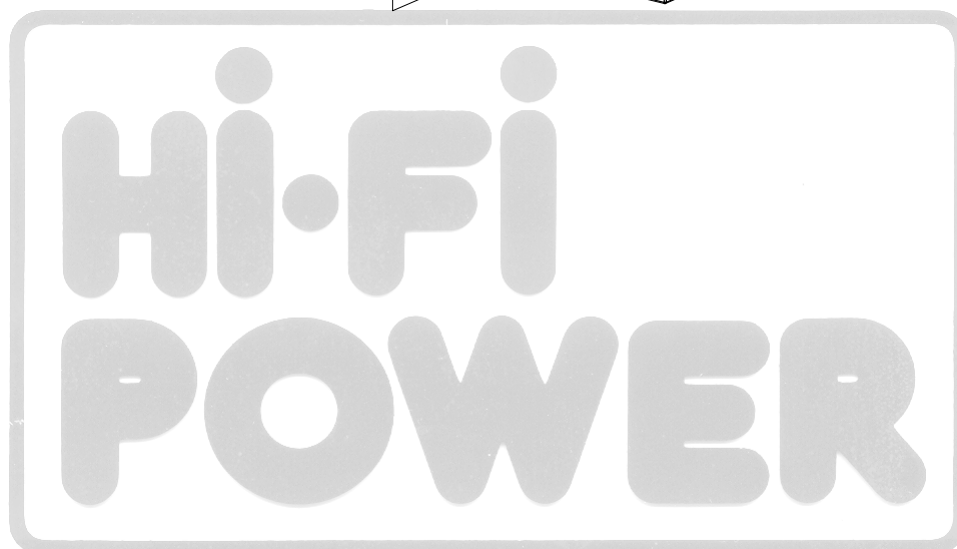
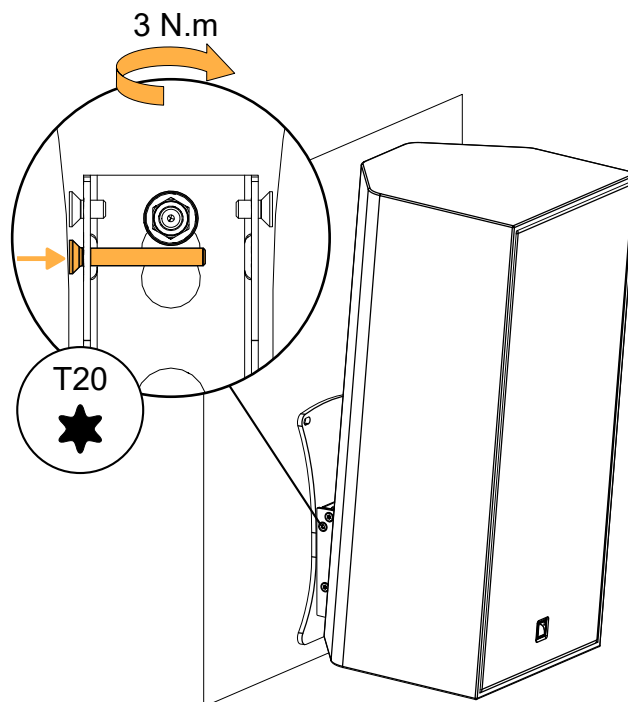

Wall-mounting X8i vertically with TILT

Type of deployment	wall-mounting
Rigging accessories	TILT-SUPPORT
	TILT
Additional material	3 compatible screws and anchors
Tools	torque screwdriver
	2 × T20 Torx bit
	T30 Torx bit
	8 mm wrench or 8 mm hex socket
Min. number of operators	2

Assembly overview

Pay attention to the position of the accessory parts throughout the procedure.

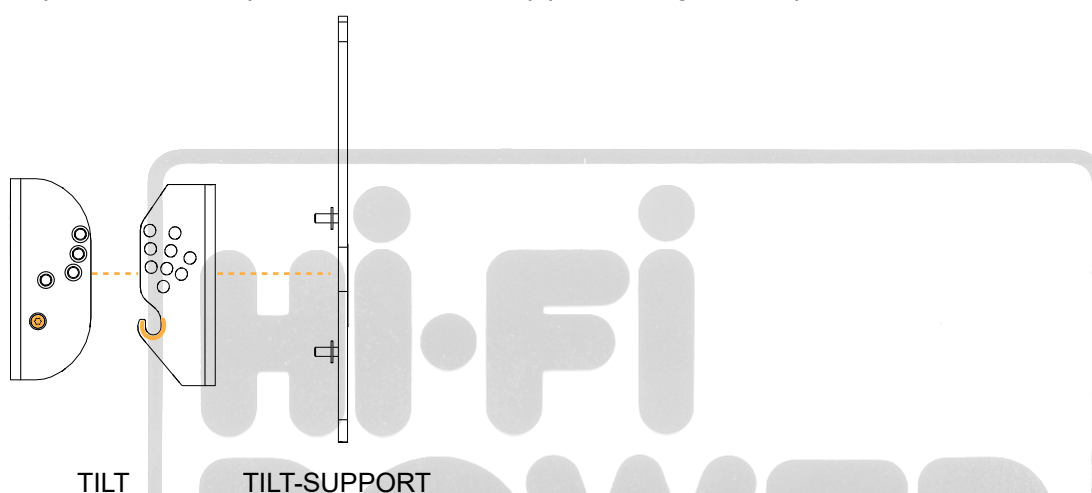

Secondary safety for flown, wall-mounted, or ceiling-mounted enclosures

Use one insert at the back of the enclosure to implement a secondary safety.

Risk of crushing injury

Ensure that the wall or ceiling can support the load of the product.

It is recommended to mount only on solid structures. If mounting on a hollow structure (such as a wall cavity), place anchoring points on the framework (wall studs, ceiling joists), or reinforce the mounting area.

Select screws and anchors applicable to the wall or ceiling properties and to the load of the product. Prevent screws from loosening over time, using for example thread locker or lock washers.

Specifications for screws and anchors

deployment	accessory	ultimate tensile load per screw (daN)	ultimate shear load per screw (daN)	screws quantity	mounting hole size	specific constraints
wall-mounting	TILT-SUPPORT + any accessory	12	9	3	Ø 6.4 mm / 0.25 in (slotted)	–

Risk of falling objects

Do not use TILT, TILT5, TILT15, or TILT40 upside-down. These rigging accessories are designed for negative site angles only.

Assembly

Prerequisite

Place X8i on its front face on a clean flat surface.

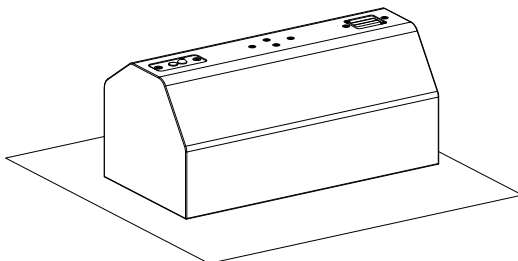

Procedure



Make sure to leave enough space between the walls and the sides of the rigging element to access the screw(s) when the enclosure is mounted.

1. Drill holes in the wall for TILT-SUPPORT.

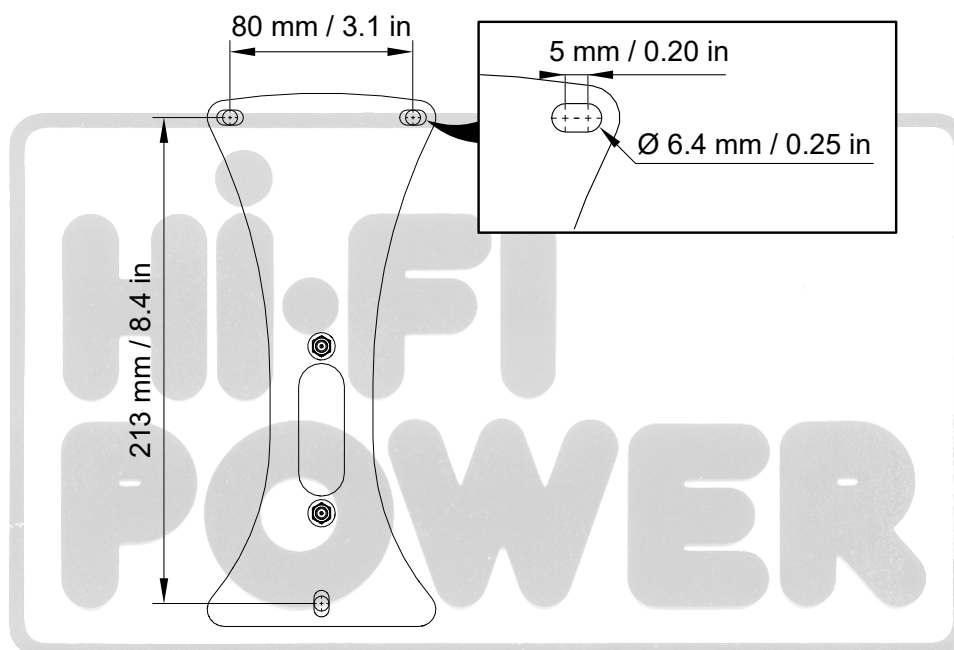

2. Disassemble the two TILT parts.

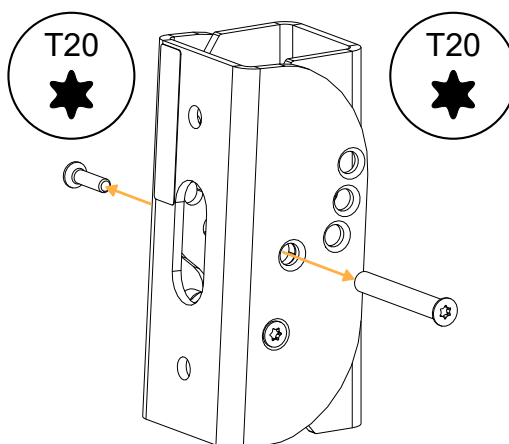

3. Assemble the TILT wall-mounting part with TILT-SUPPORT.

Use the two M5 nuts and washers.

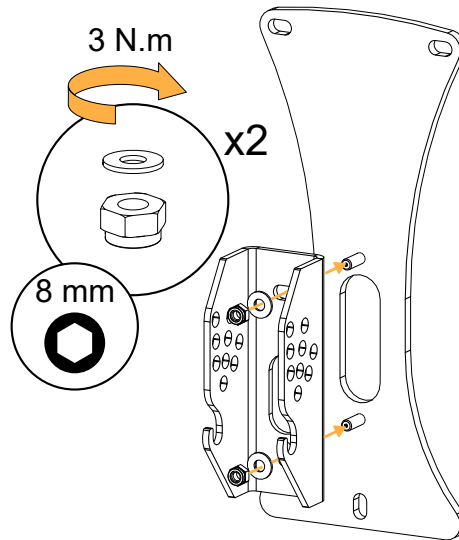

4. Secure TILT-SUPPORT and TILT to the wall.

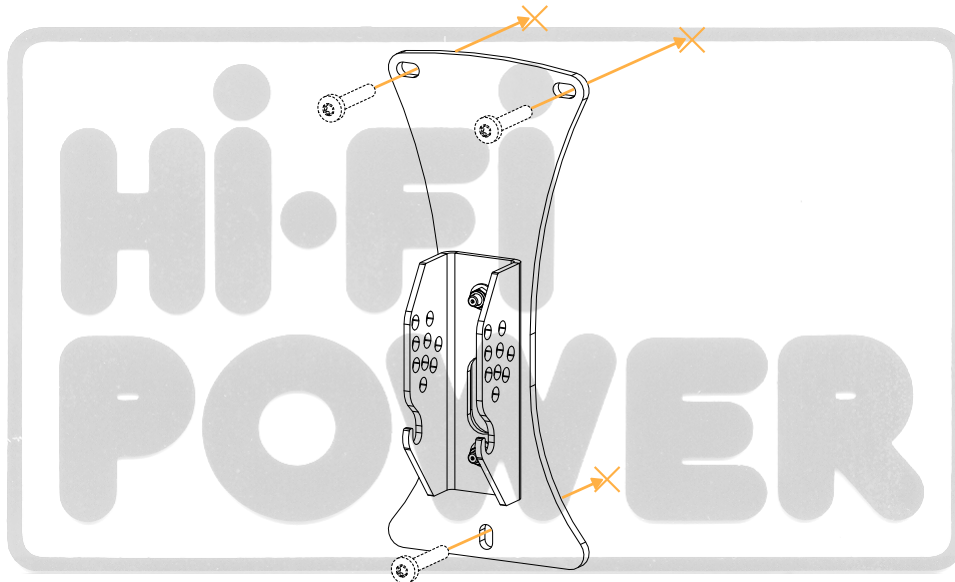

5. Secure TILT to X8i:

- a) Remove the two placeholder screws at the bottom of X8i.
- b) Secure the TILT enclosure-mounting part to X8i.

Use the two M6×25 Torx screws.

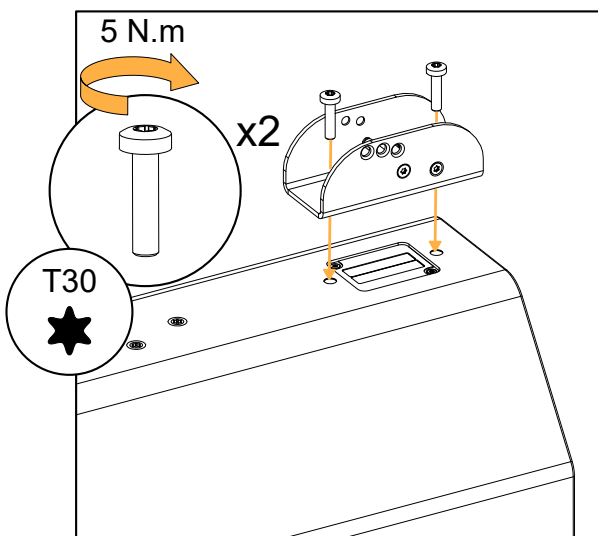
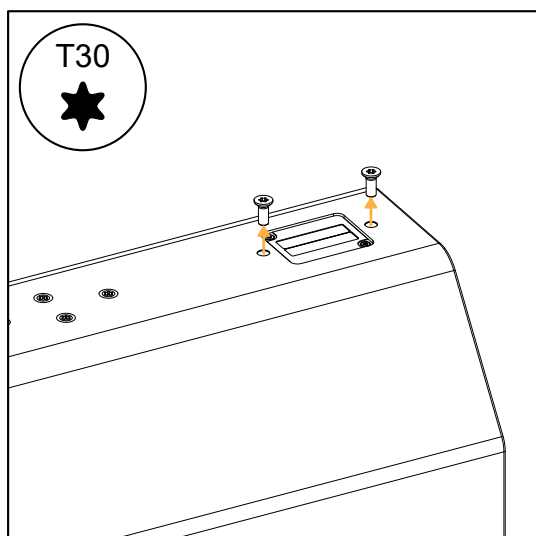
6. Prepare the cabling. Refer to [Cabling X8i](#) (p.171).**Risk of pinching fingers**

Hold X8i from underneath when assembling the two TILT parts.

7. Mount X8i on the wall:

- a) Assemble the two TILT parts by fitting the indexing studs into the hooks.

Make sure that the studs are pushed all the way into the hooks.

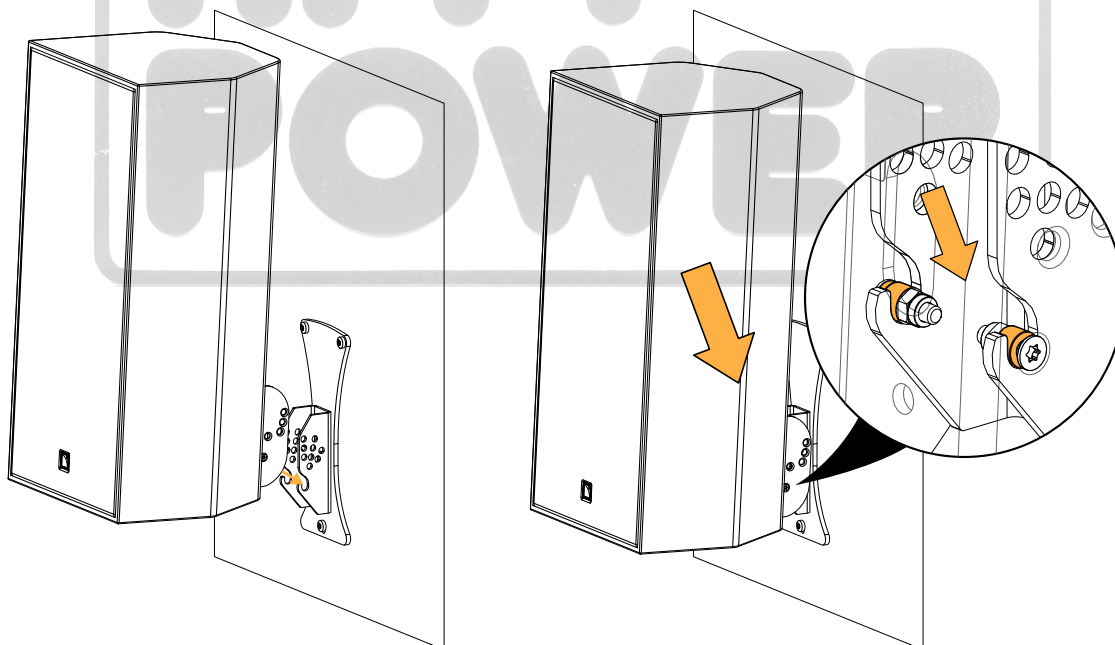

b) Rotate the assembly to select the site angle.

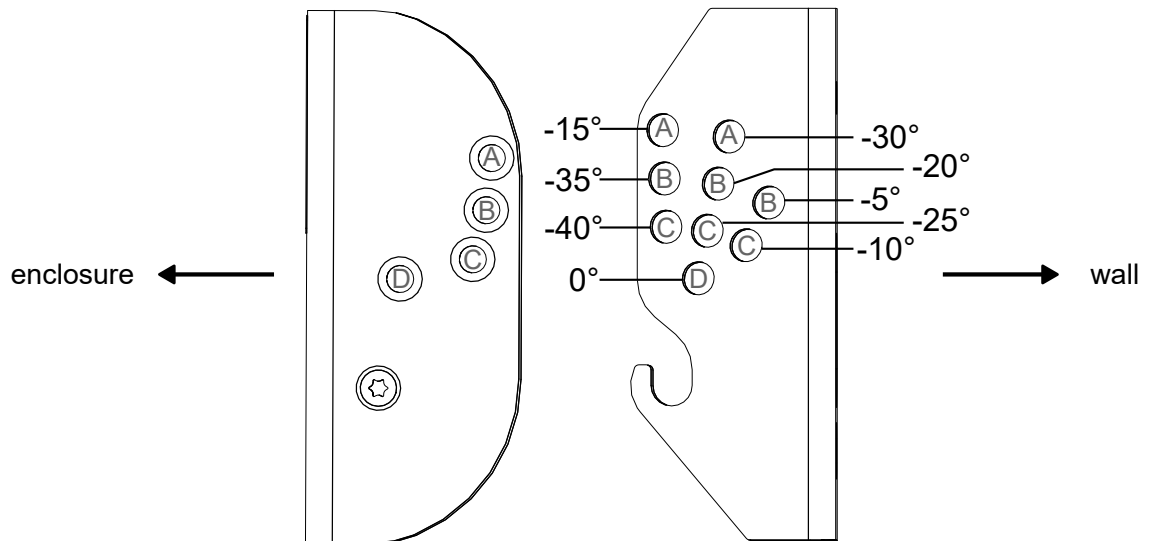

c) Drive the axis through the holes and secure it with the M4×16 Torx screw.

Make sure that the assembly is stable.

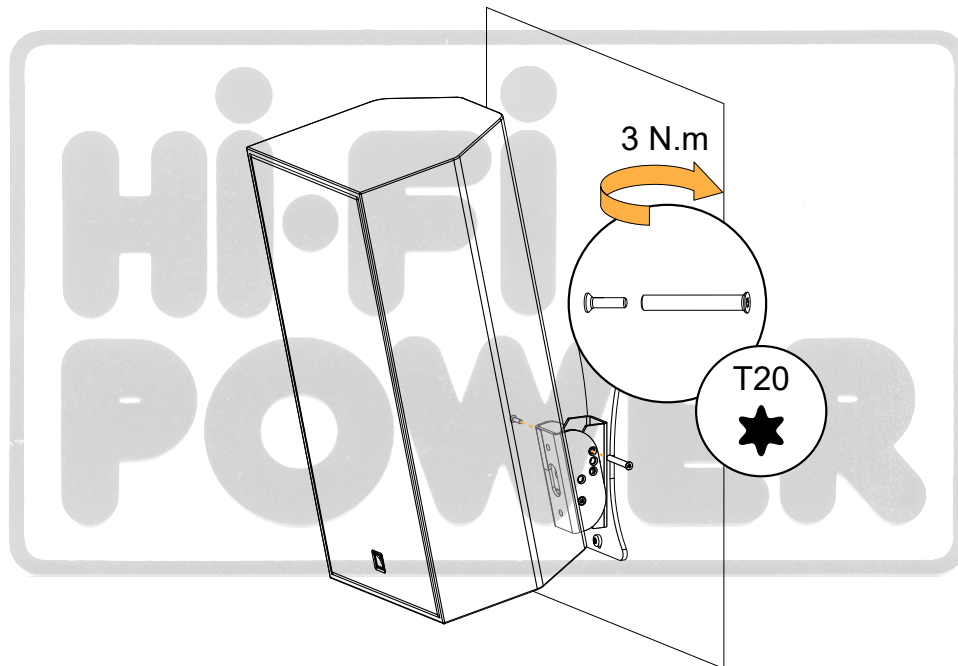

Wall-mounting X8i vertically with PANx2

Type of deployment	wall-mounting
Rigging accessories	PANx2
Additional material	4 compatible screws and anchors
Tools	torque screwdriver
	T30 Torx bit
	T40 Torx bit
Min. number of operators	1

! Secondary safety for flown, wall-mounted, or ceiling-mounted enclosures
Use one insert at the back of the enclosure to implement a secondary safety.

! Risk of crushing injury
Ensure that the wall or ceiling can support the load of the product.
It is recommended to mount only on solid structures. If mounting on a hollow structure (such as a wall cavity), place anchoring points on the framework (wall studs, ceiling joists), or reinforce the mounting area.
Select screws and anchors applicable to the wall or ceiling properties and to the load of the product. Prevent screws from loosening over time, using for example thread locker or lock washers.

Specifications for screws and anchors

deployment	accessory	ultimate tensile load per screw (daN)	ultimate shear load per screw (daN)	screws quantity	mounting hole size	specific constraints
wall-mounting	PANx2	6	5	4	Ø 6.4 mm / 0.25 in (slotted)	–

! Risk of falling objects
Do not use PAN or PANx2 upside-down.
Do not swap the wall-mounting part(s) and the enclosure-mounting part(s).

! SPCON cannot be used in this configuration.

Screws and fasteners

from PANx2

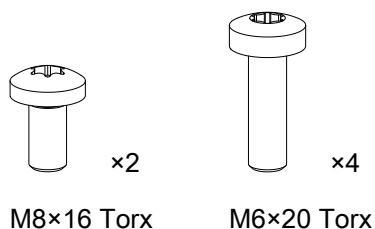

Assembly

About this task

! For this configuration, the speaker cable must be run inside the wall.

Prerequisite

Place X8i on its front face on a clean flat surface.

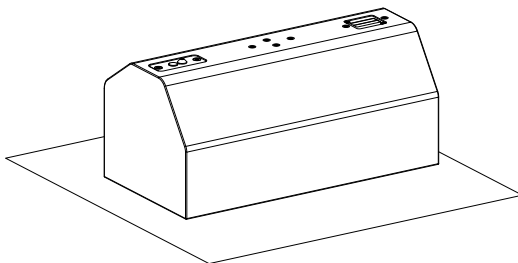

Procedure

1. Drill holes in the wall for the anchors and for the cable exit.

Use the provided drilling template.

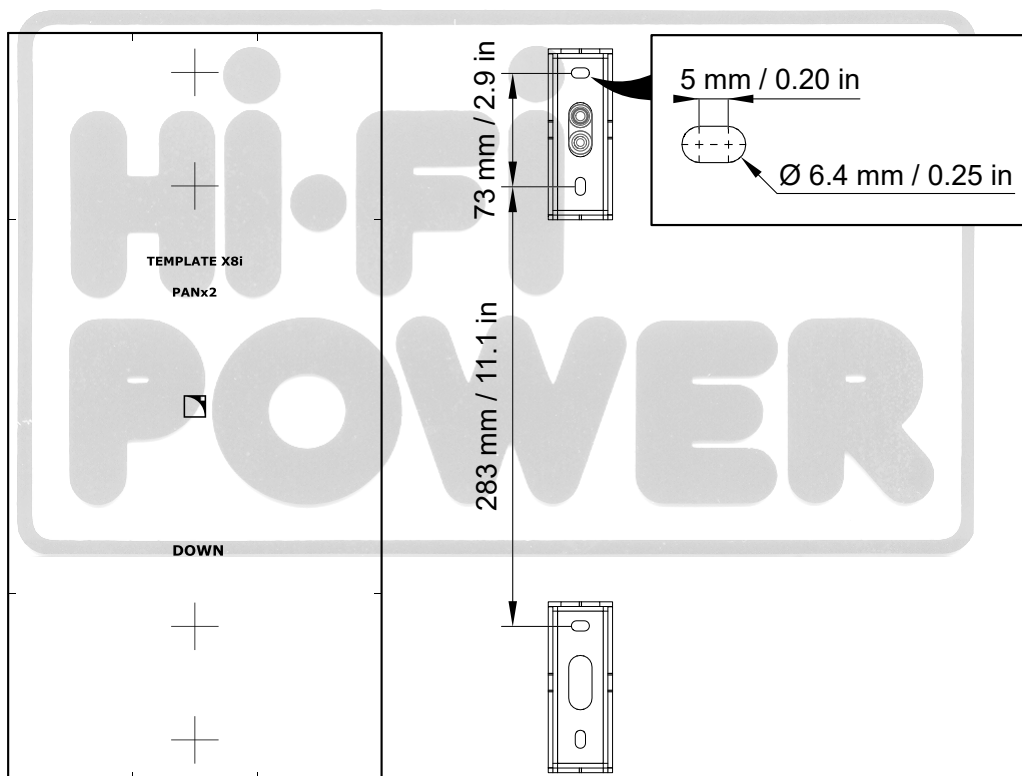

2. Run the speaker cable inside the wall.

3. Secure the two PANx2 wall-mounting parts to the wall.

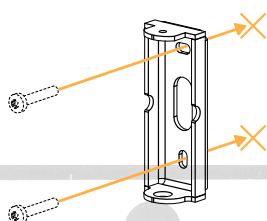
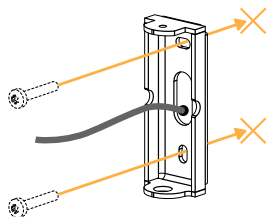

4. Secure the top PANx2 part to X8i:

- Remove the connector sealing plate.
- Run the cable through the PANx2 part and through the connector sealing plate.
- Connect the cable to the X8i terminal block. Refer to [Cabling X8i](#) (p.171).
- Secure the PANx2 part and the connector sealing plate to X8i.

Use two M6×20 Torx screws.

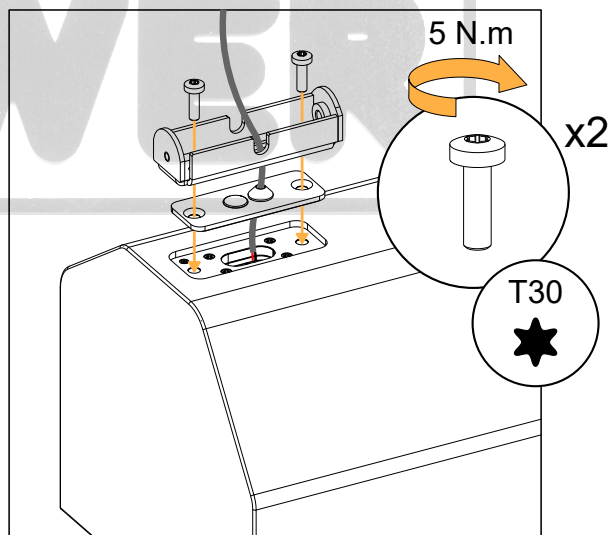
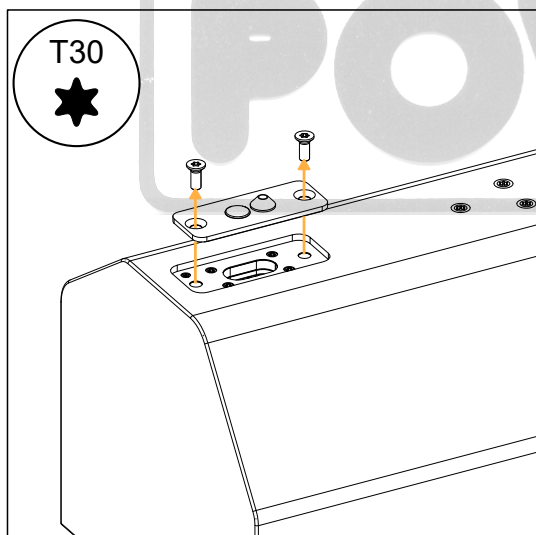

5. Secure the bottom PANx2 part to X8i:

- a) Remove the two bottom placeholder screws.
- b) Secure the PANx2 part to X8i.

Use two M6×20 Torx screws.

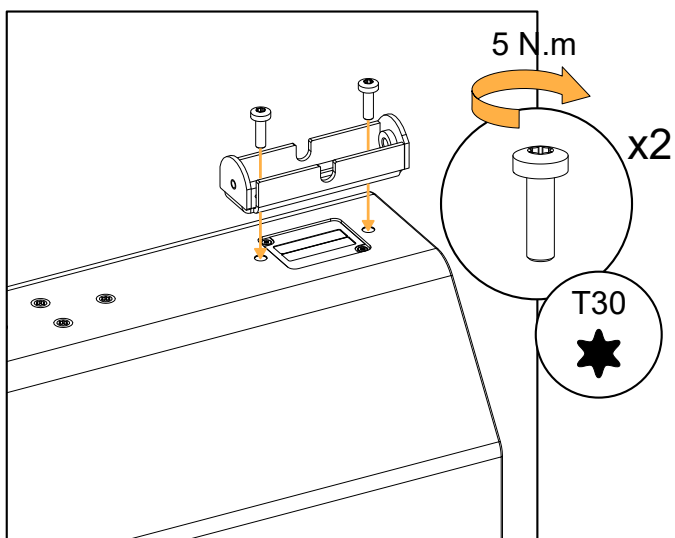
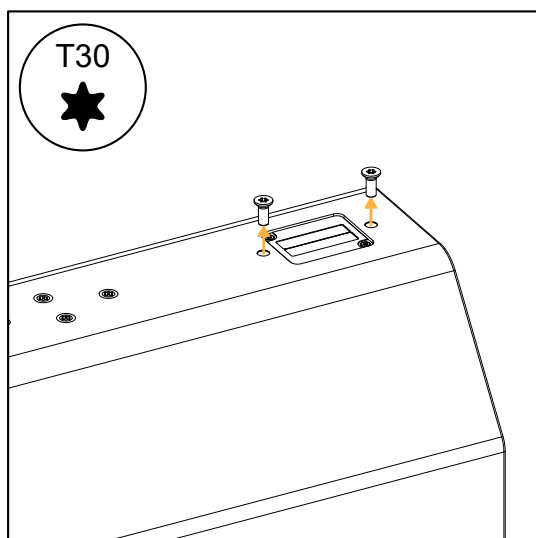

6. Mount the assembly on the wall-mounting parts:

- a) Align the pins with the top holes and push the assembly downwards.
- b) Drive the two M8×16 Torx screws from underneath the PANx2 parts.

! Do not fully tighten the screws.

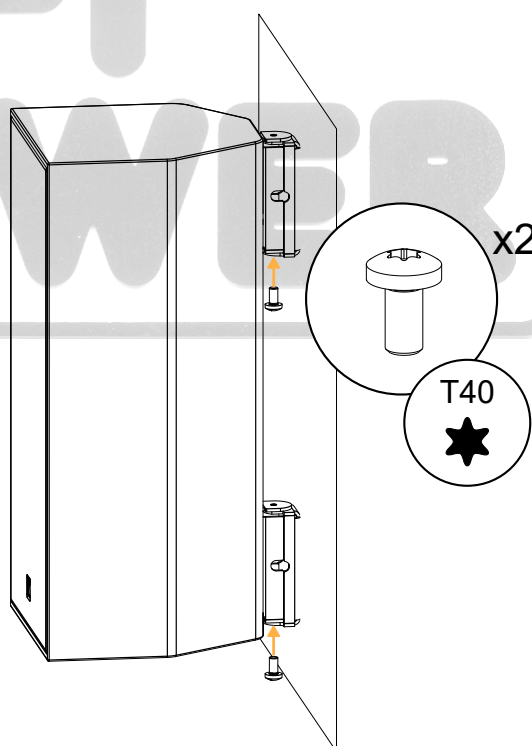
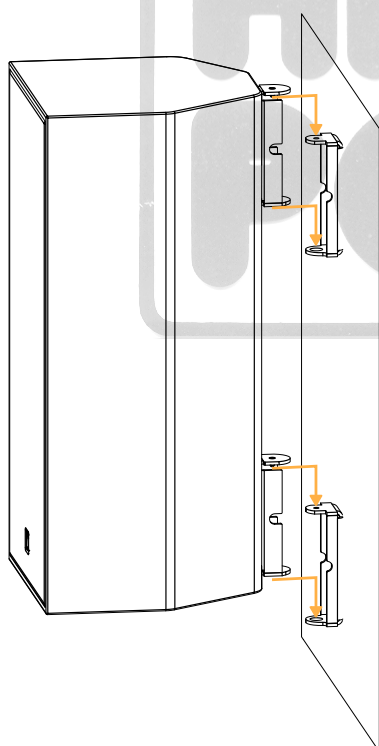

7. Rotate X8i to adjust the azimuth angle from -45° to $+45^{\circ}$.

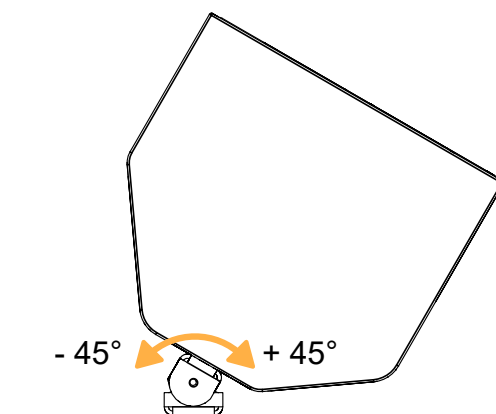

8. Tighten the two M8×16 Torx screws. Apply a torque of 10 N.m.
Make sure the assembly is stable.

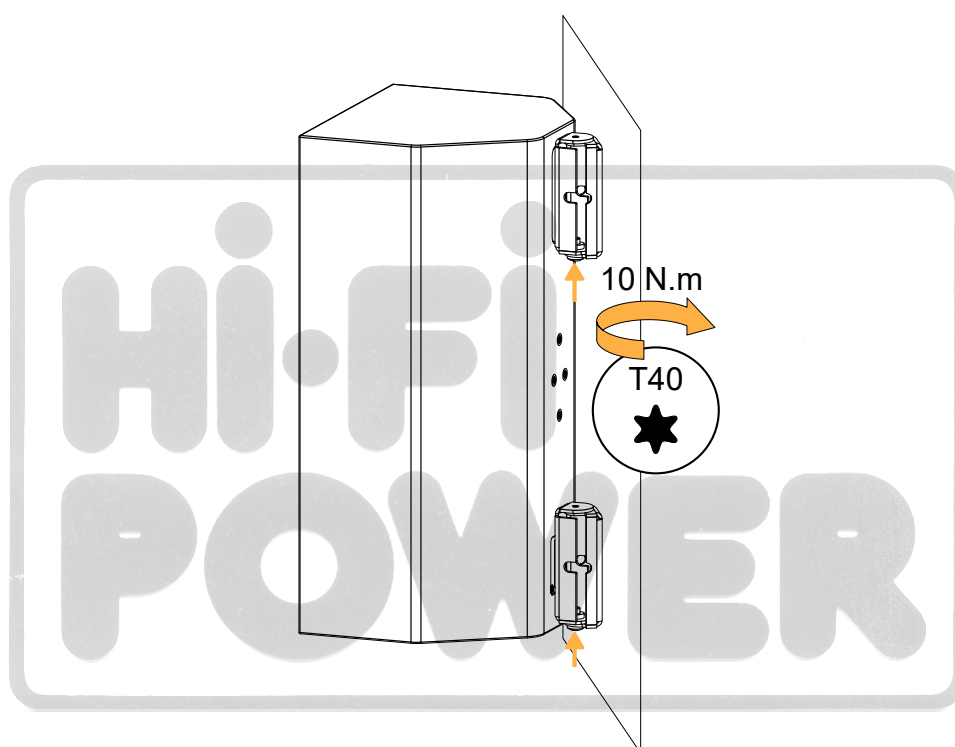

Wall-mounting X8i vertically with PAN and TILT5/TILT15/TILT40

Type of deployment	wall-mounting
Rigging accessories	TILT-SUPPORT
	PAN
	TILT5/TILT15/TILT40
Additional material	3 compatible screws and anchors
Tools	torque screwdriver
	T20 Torx bit
	T25 Torx bit
	T30 Torx bit
	T40 Torx bit
	8 mm wrench or 8 mm hex socket
Min. number of operators	1

Assembly overview

Pay attention to the position of the accessory parts throughout the procedure.

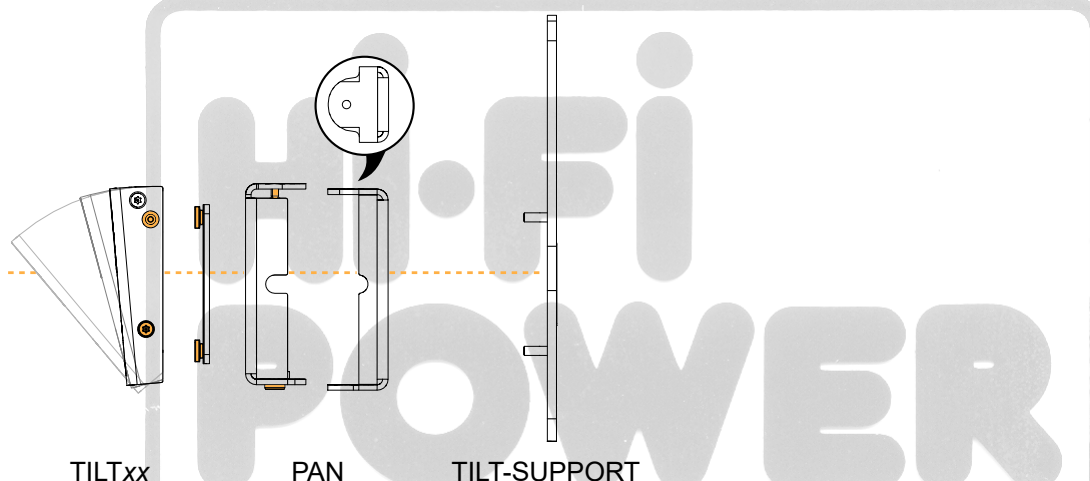

Secondary safety for flown, wall-mounted, or ceiling-mounted enclosures

Use one insert at the back of the enclosure to implement a secondary safety.

Risk of crushing injury



Ensure that the wall or ceiling can support the load of the product.

It is recommended to mount only on solid structures. If mounting on a hollow structure (such as a wall cavity), place anchoring points on the framework (wall studs, ceiling joists), or reinforce the mounting area.

Select screws and anchors applicable to the wall or ceiling properties and to the load of the product. Prevent screws from loosening over time, using for example thread locker or lock washers.



Specifications for screws and anchors

deployment	accessory	ultimate tensile load per screw (daN)	ultimate shear load per screw (daN)	screws quantity	mounting hole size	specific constraints
wall-mounting	TILT-SUPPORT + any accessory	12	9	3	Ø 6.4 mm / 0.25 in (slotted)	–

-  **Risk of falling objects**
Do not use PAN or PANx2 upside-down.
Do not swap the wall-mounting part(s) and the enclosure-mounting part(s).
-  **Risk of falling objects**
Do not use TILT, TILT5, TILT15, or TILT40 upside-down. These rigging accessories are designed for negative site angles only.

Screws and fasteners

from TILT-SUPPORT

-  x2
-  x2
- M5 hex locknut
- thick plain washer Ø 5 mm

from PAN

-  x2
-  x2
-  x2
-  x2
- M5x20 Torx
- M5 hex locknut
- thick plain washer Ø 5 mm
- M8x16 Torx

from TILT5/TILT15/TILT40

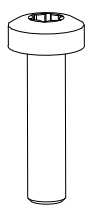
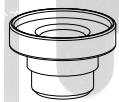
-  x2
-  x2
- M6x25 Torx
- M5 tapered spacer

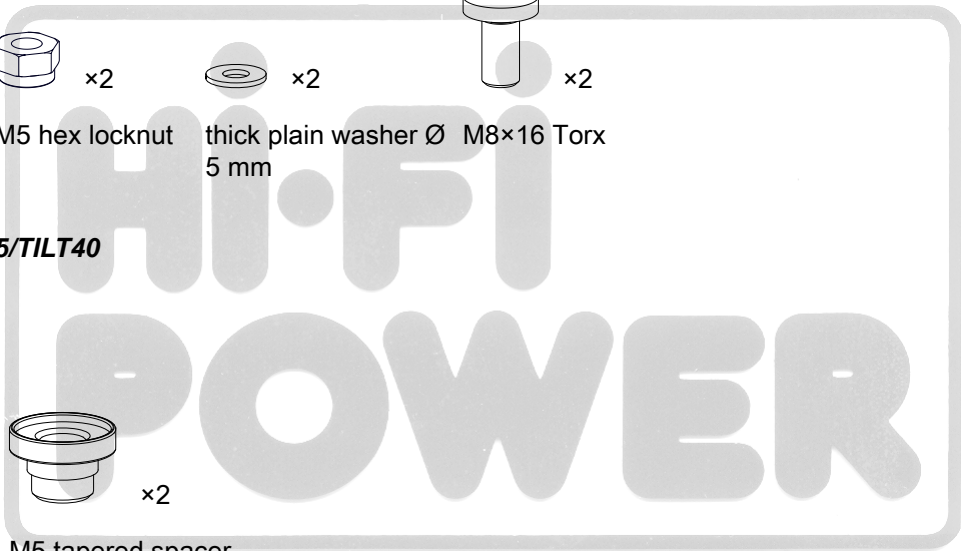

Assembly

About this task

i In this procedure, TILTxx designates the fixed angle accessories TILT5, TILT15, and TILT40.

Prerequisite

Place X8i on its front face on a clean flat surface.

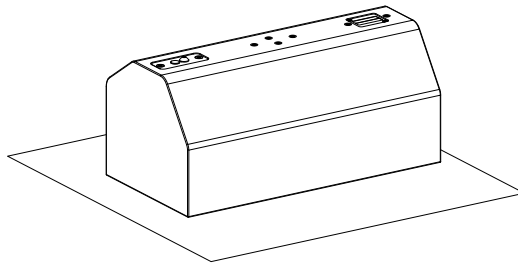

Make sure that the TILTxx safety screw is present and loosened.

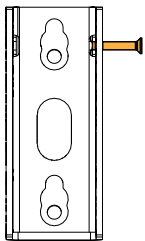

Procedure

! Make sure to leave enough space between the walls and the sides of the rigging element to access the screw(s) when the enclosure is mounted.

1. Drill holes in the wall for TILT-SUPPORT.

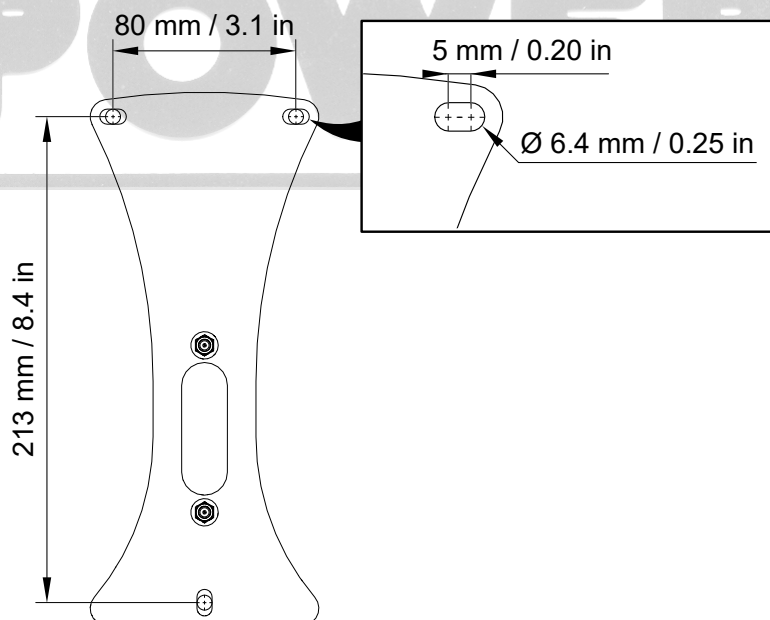

2. Assemble the PAN wall-mounting part with TILT-SUPPORT.

Use the two M5 nuts and washers.

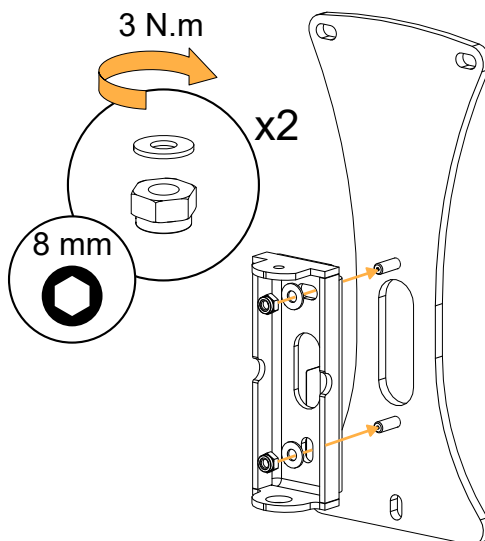

3. Secure TILT-SUPPORT and PAN to the wall.

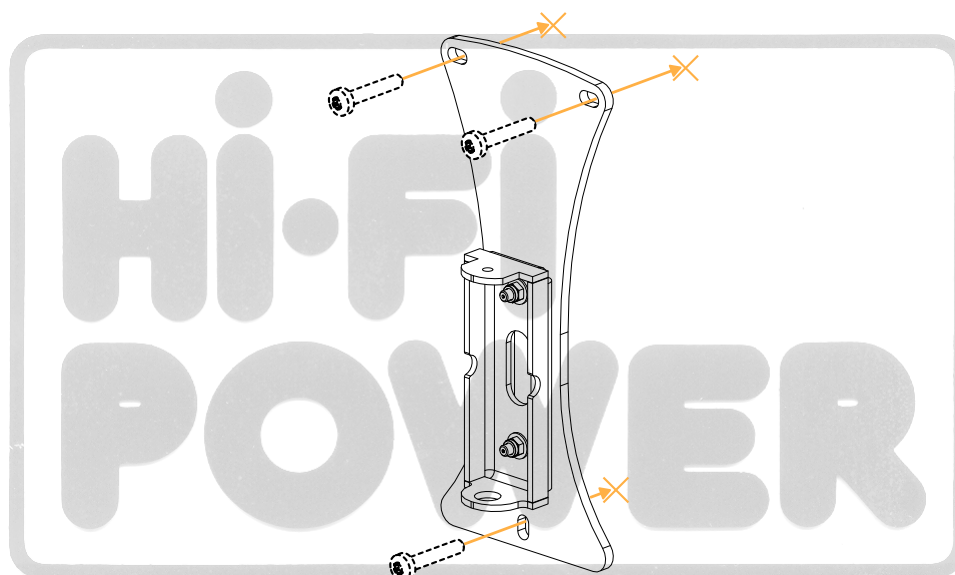

4. Assemble the wall-mounting plate and tapered spacers with PAN.

Use two M5×20 Torx screws, two M5 washers, and two M5 nuts.

The wall-mounting plate gasket is facing away from PAN.

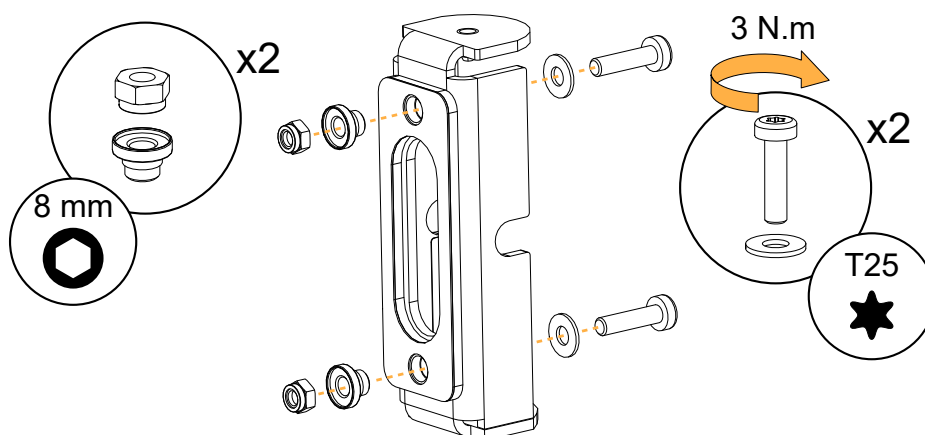

5. Mount the assembly on the PAN wall-mounting part:

- a) Align the pin with the top hole and push the assembly downwards.
- b) Drive the M8×16 Torx screw from underneath PAN.

! Do not fully tighten the screw.

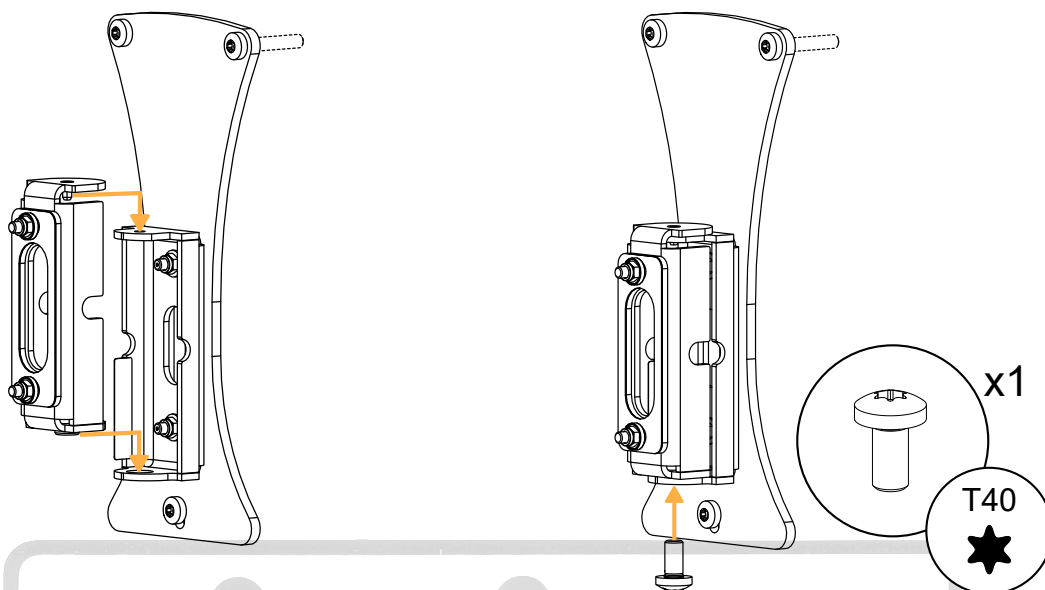

6. Secure TILTxx to X8i:

- a) Remove the two placeholder screws at the bottom of X8i.
- b) Secure TILTxx to X8i.

Use the two M6×25 Torx screws.

i If the shank of the screwdriver collides with TILT40, use a screwdriver extension or an angled screwdriver to drive the screws.

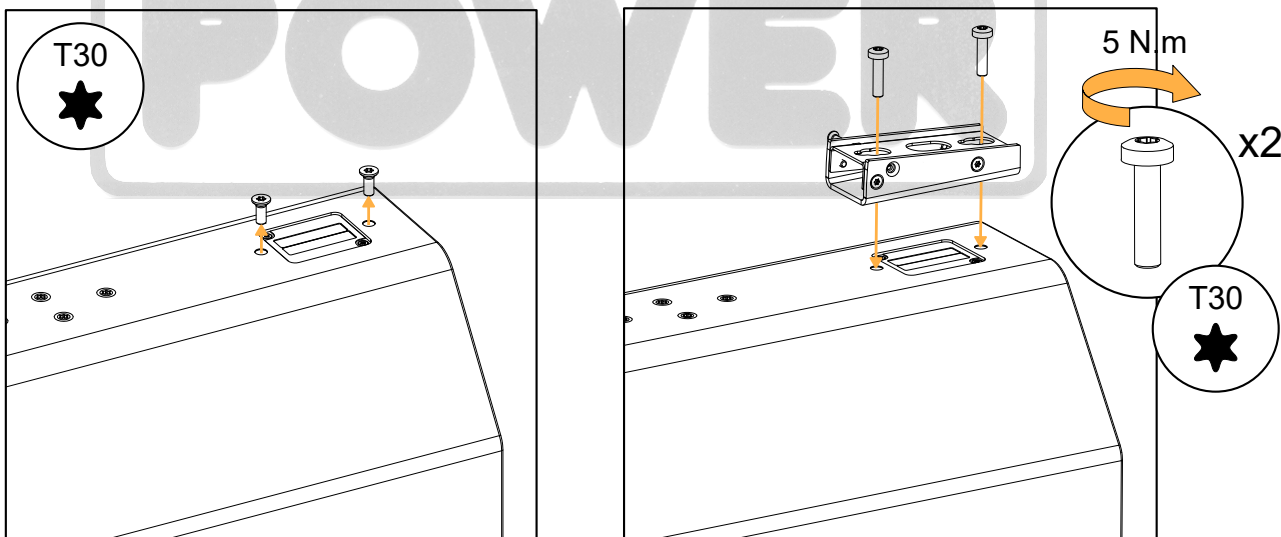

7. Prepare the cabling. Refer to [Cabling X8i](#) (p.171).

8. Mount X8i on PAN:

- a) Align the midpoints of the TILTxx rear cutouts with the tapered spacers.
- b) Push the assembly downwards.

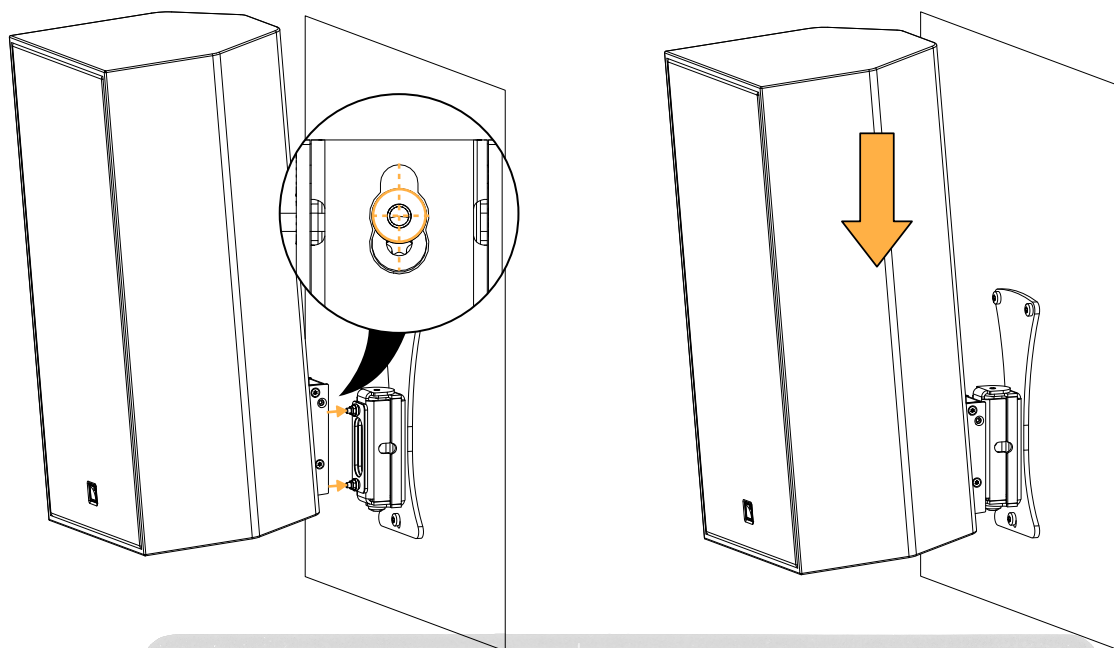

9. Tighten the safety screw on TILTxx.

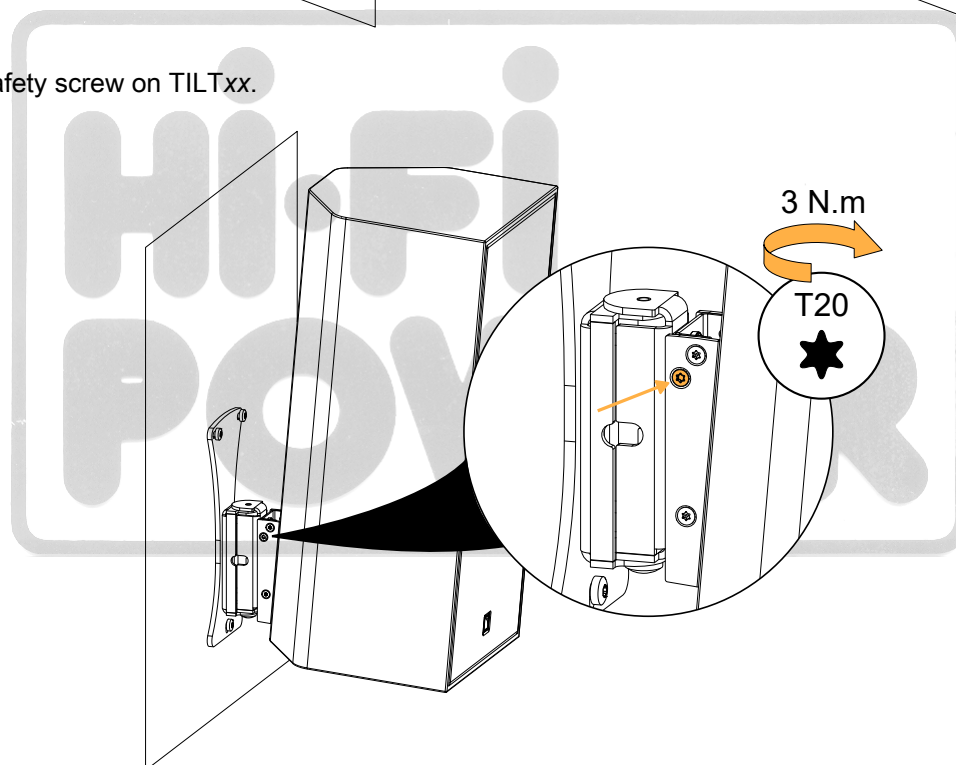

10. Rotate the assembly to adjust the azimuth angle from -45° to $+45^{\circ}$.

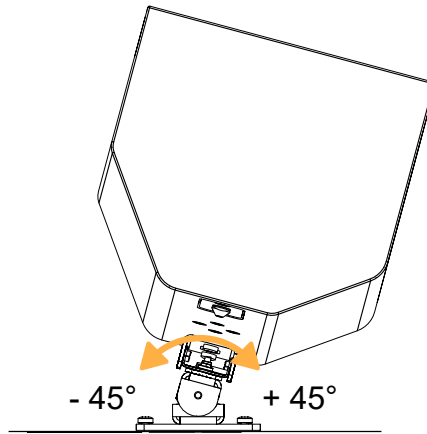

11. Tighten the M8×16 Torx screw. Apply a torque of 10 N.m.
Make sure the assembly is stable.

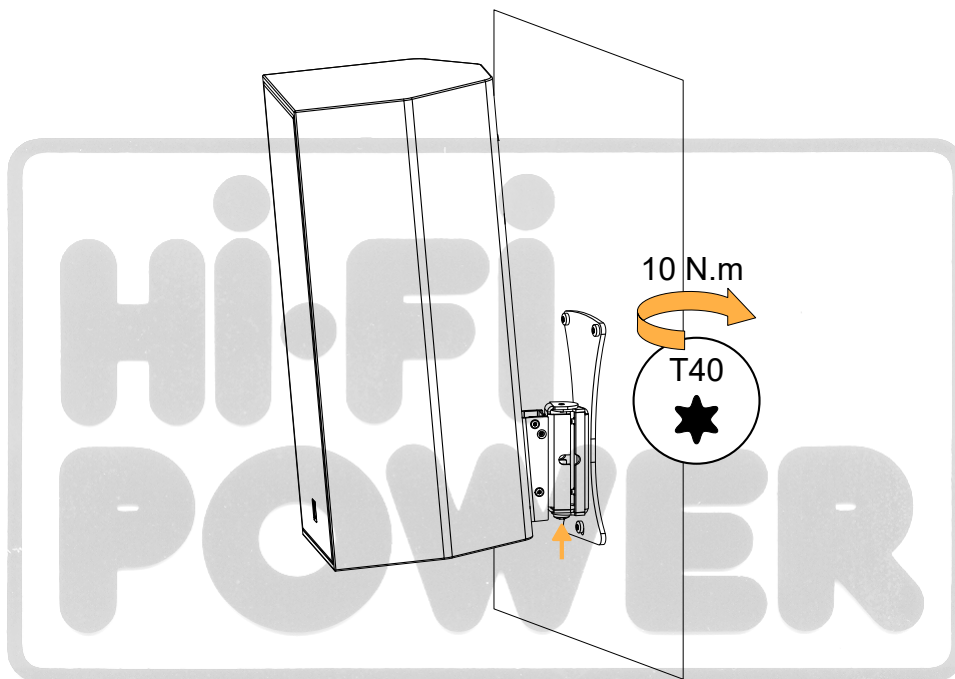

Wall-mounting X8i vertically with PAN and TILT

Type of deployment	wall-mounting
Rigging accessories	TILT-SUPPORT
	PAN
	TILT
Additional material	3 compatible screws and anchors
Tools	torque screwdriver
	T20 Torx bit
	T30 Torx bit
	T40 Torx bit
	T20 screwdriver
	8 mm wrench or 8 mm hex socket
	10 mm wrench or 10 mm hex socket
Min. number of operators	2

Assembly overview

Pay attention to the position of the accessory parts throughout the procedure.

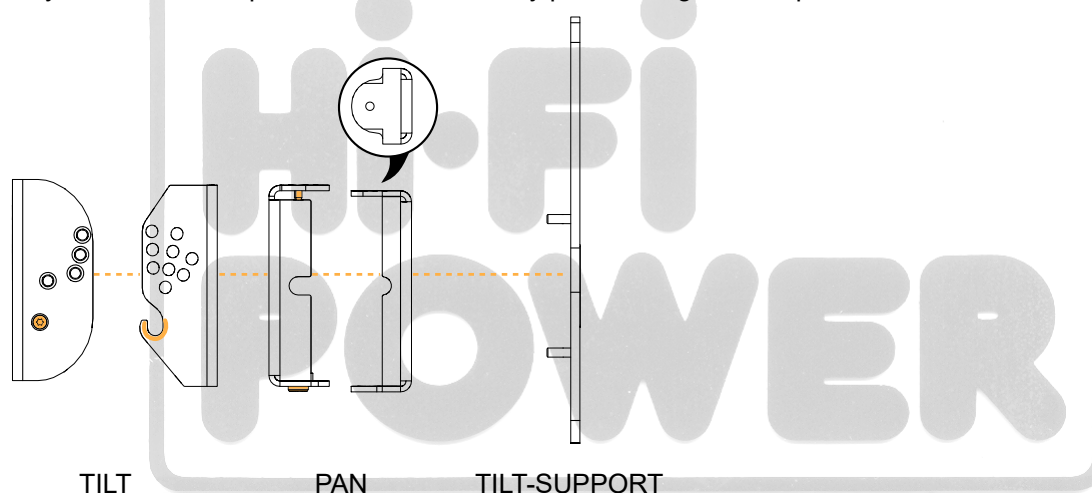

Secondary safety for flown, wall-mounted, or ceiling-mounted enclosures

Use one insert at the back of the enclosure to implement a secondary safety.

Risk of crushing injury

Ensure that the wall or ceiling can support the load of the product.

It is recommended to mount only on solid structures. If mounting on a hollow structure (such as a wall cavity), place anchoring points on the framework (wall studs, ceiling joists), or reinforce the mounting area.

Select screws and anchors applicable to the wall or ceiling properties and to the load of the product. Prevent screws from loosening over time, using for example thread locker or lock washers.

Specifications for screws and anchors

deployment	accessory	ultimate tensile load per screw (daN)	ultimate shear load per screw (daN)	screws quantity	mounting hole size	specific constraints
wall-mounting	TILT-SUPPORT + any accessory	12	9	3	Ø 6.4 mm / 0.25 in (slotted)	–

- ⚠ Risk of falling objects**
Do not use PAN or PANx2 upside-down.
Do not swap the wall-mounting part(s) and the enclosure-mounting part(s).
- ⚠ Risk of falling objects**
Do not use TILT, TILT5, TILT15, or TILT40 upside-down. These rigging accessories are designed for negative site angles only.

Screws and fasteners

from TILT-SUPPORT

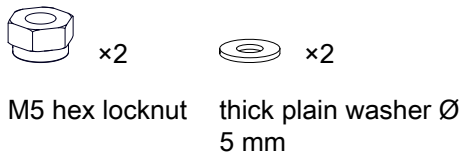

from PAN

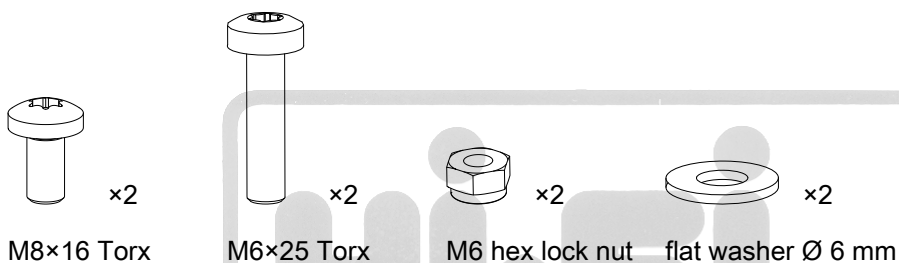

from TILT

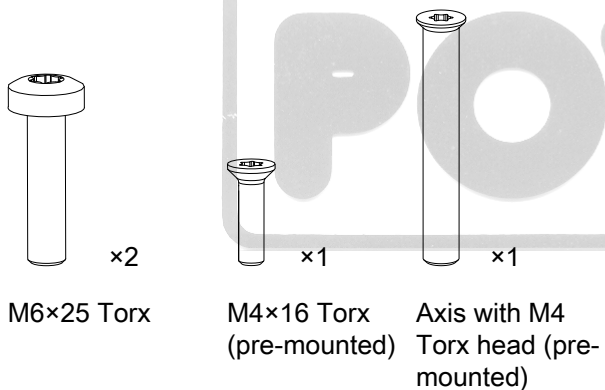

Assembly

Prerequisite

Place X8i on its front face on a clean flat surface.

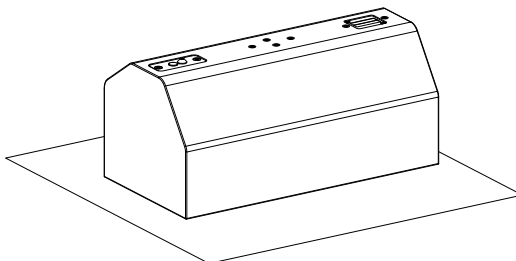

Procedure



Make sure to leave enough space between the walls and the sides of the rigging element to access the screw(s) when the enclosure is mounted.

1. Drill holes in the wall for TILT-SUPPORT.

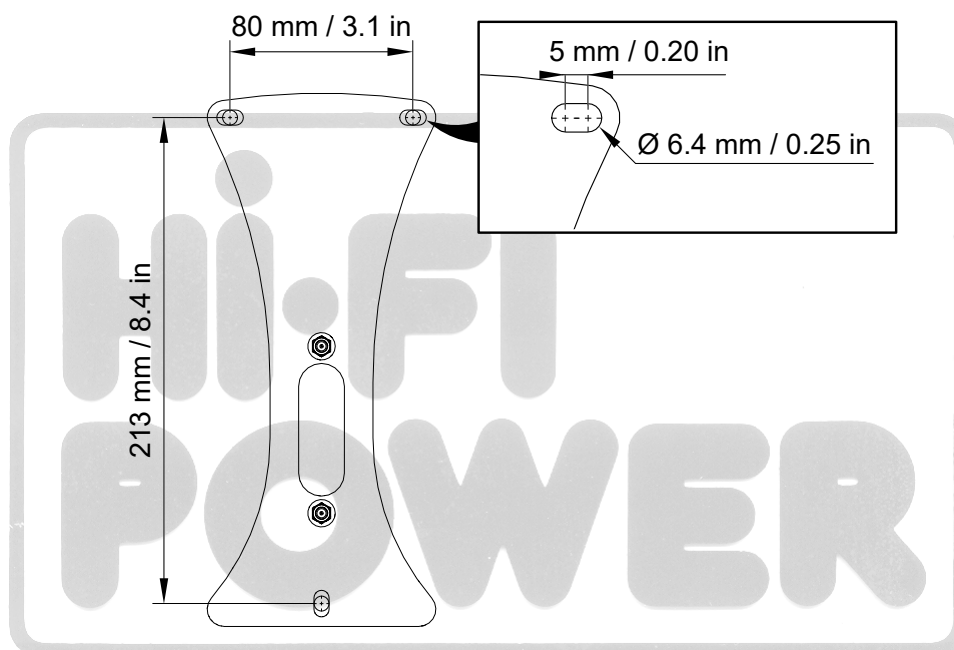

2. Assemble the PAN wall-mounting part with TILT-SUPPORT.

Use the two M5 nuts and washers.

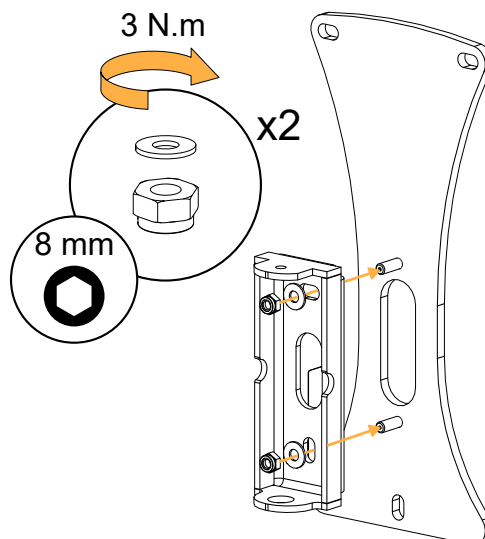

3. Secure TILT-SUPPORT and PAN to the wall.

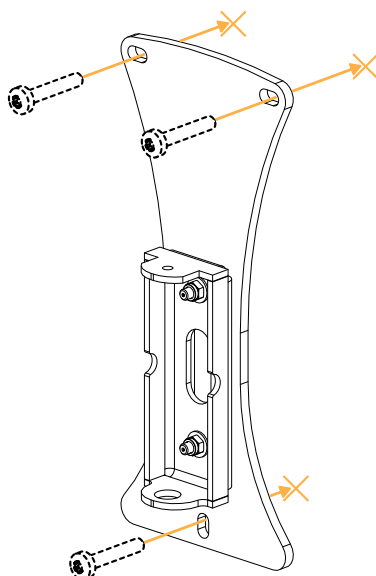

4. Disassemble the two TILT parts.

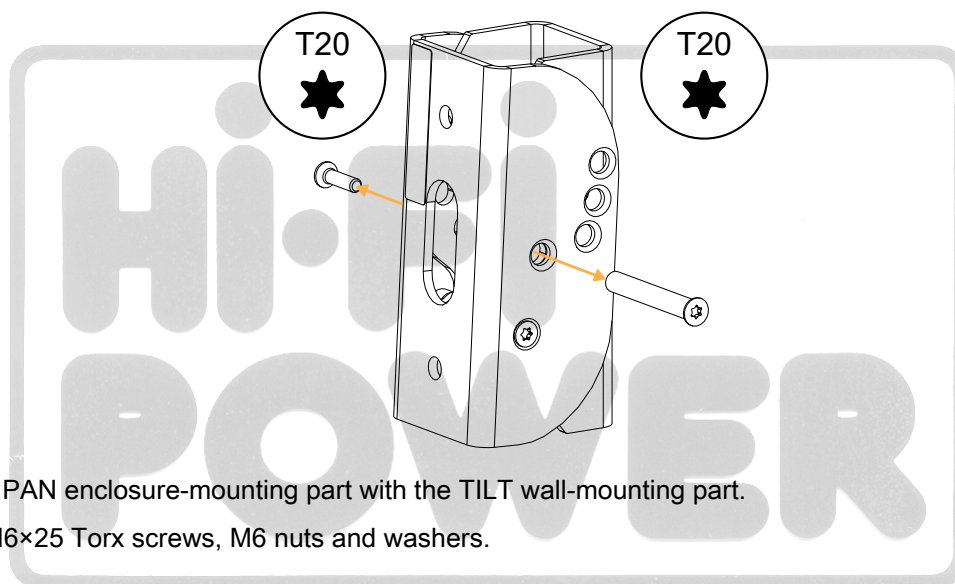

5. Assemble the PAN enclosure-mounting part with the TILT wall-mounting part. Use the two M6×25 Torx screws, M6 nuts and washers.

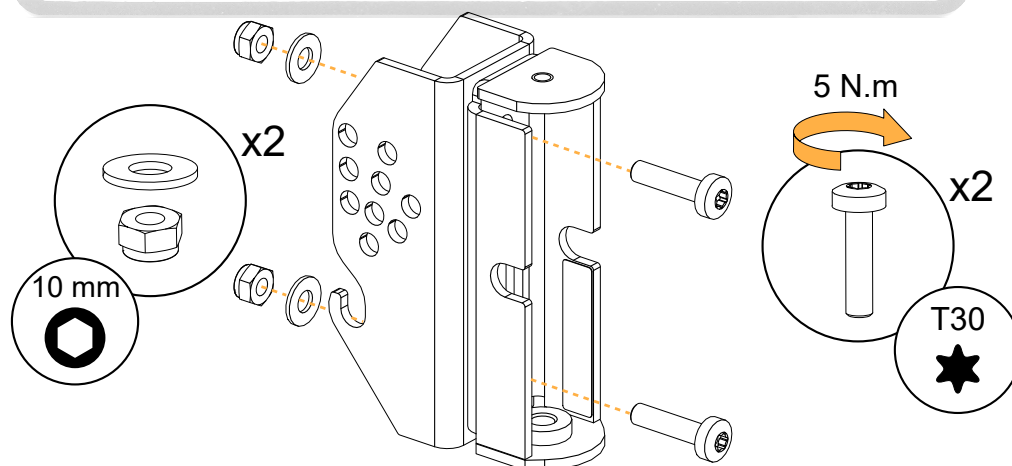

6. Mount the assembly on the PAN wall-mounting part:

- a) Align the pin with the top hole and push the assembly downwards.
- b) Drive the M8×16 Torx screw from underneath PAN.



Do not fully tighten the screw.

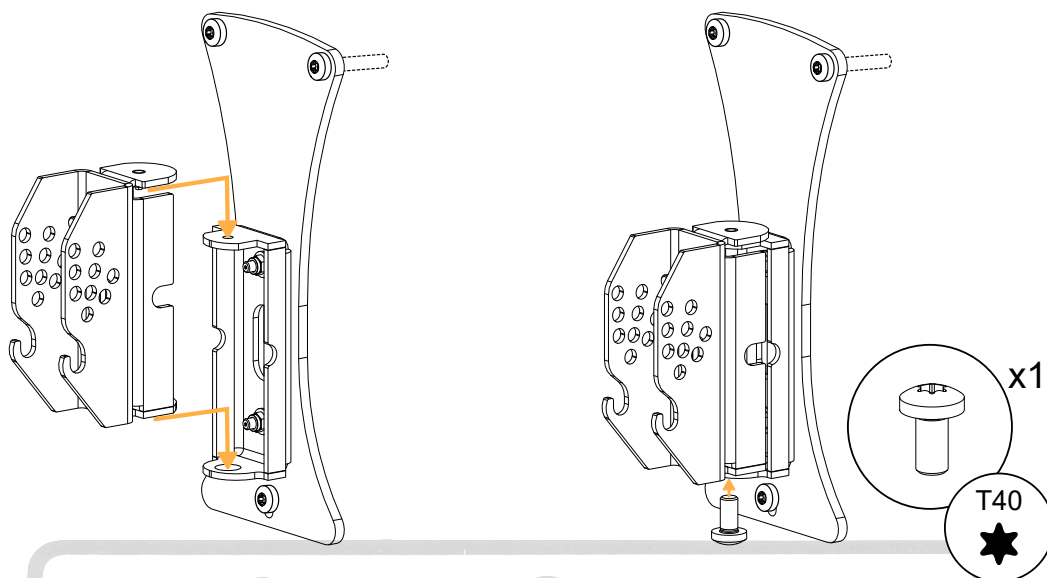

7. Secure TILT to X8i:

- a) Remove the two placeholder screws at the bottom of X8i.
- b) Secure the TILT enclosure-mounting part to X8i.

Use the two M6×25 Torx screws.

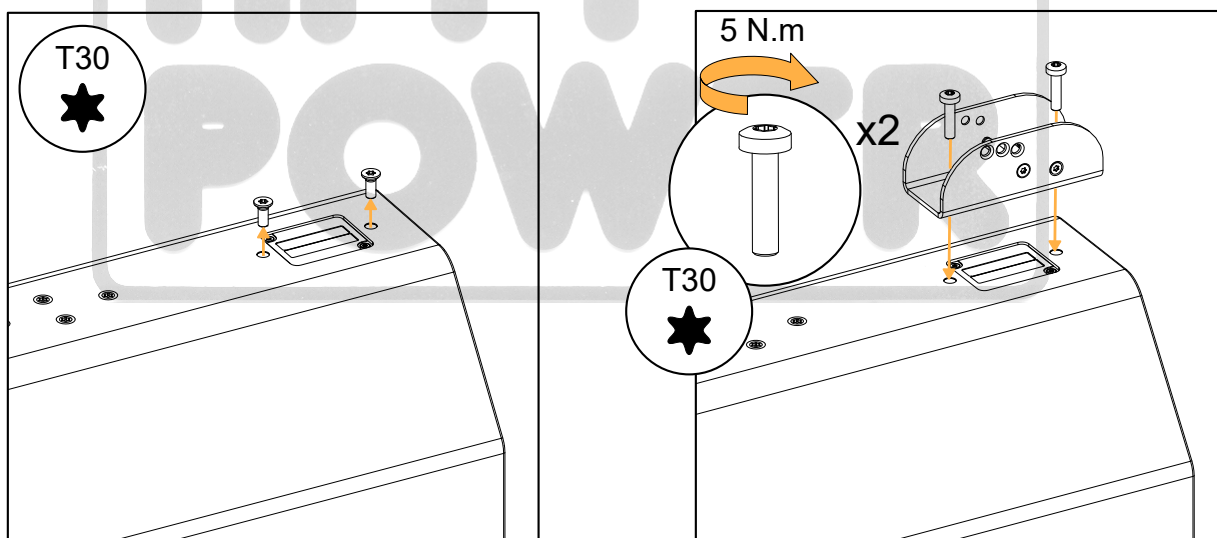

8. Prepare the cabling. Refer to [Cabling X8i](#) (p.171).

9. Mount X8i on the PAN and TILT assembly:

a) Assemble the two TILT parts by fitting the indexing studs into the hooks.

Make sure the studs are pushed all the way into the hooks.

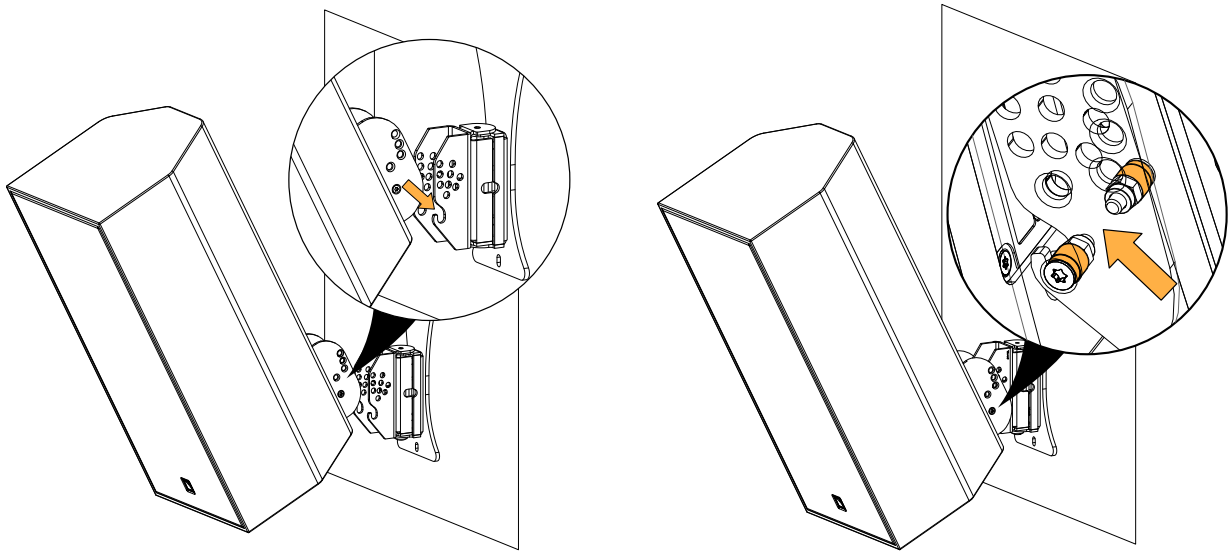

b) Rotate the assembly to select the site angle.

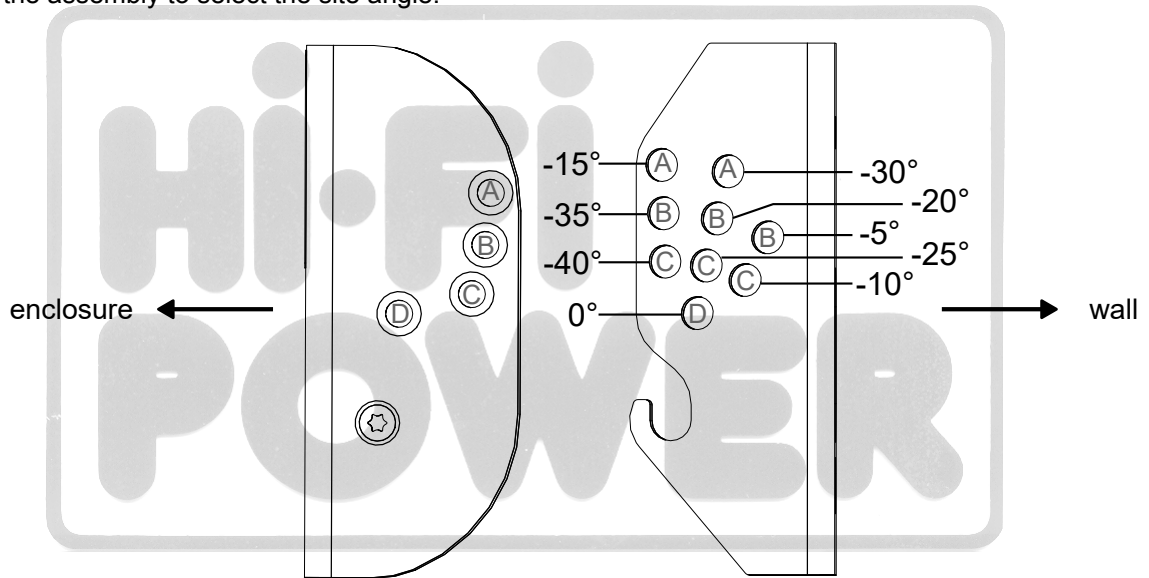

c) Drive the axis through the holes and secure it with the M4×16 Torx screw.

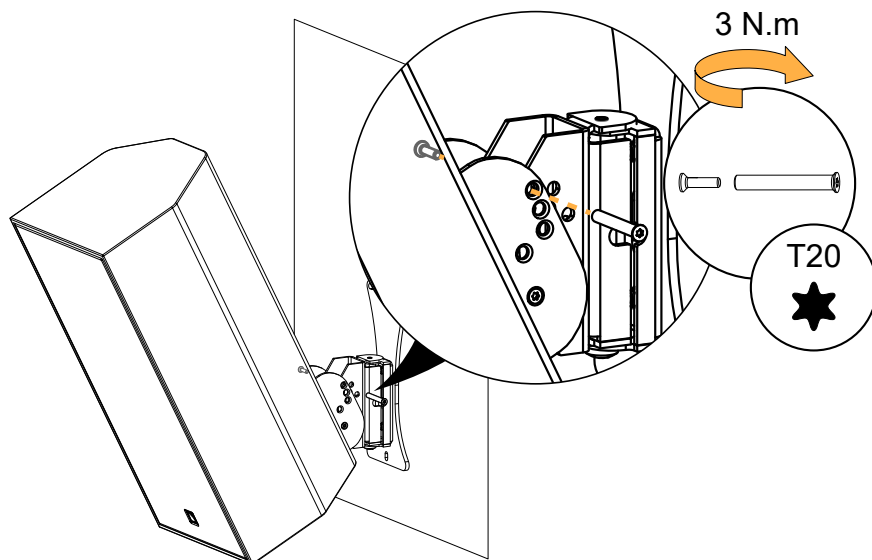

10. Rotate X8i to adjust the azimuth angle from -45° to $+45^{\circ}$.

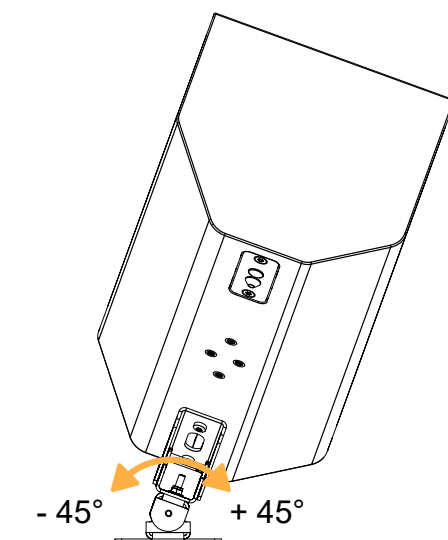



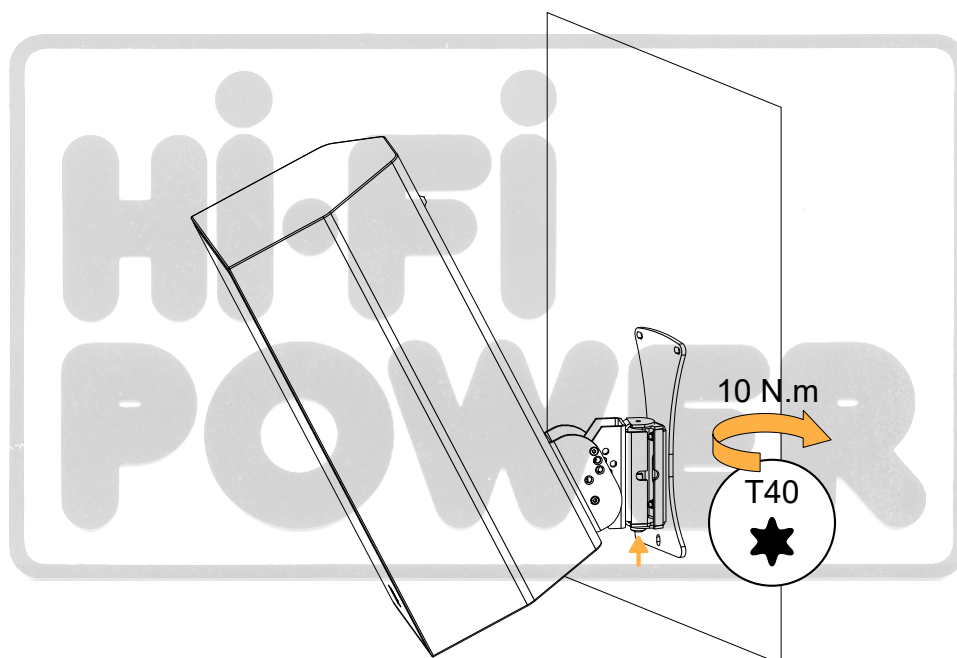



11. Tighten the M8×16 Torx screw. Apply a torque of 10 N.m.
Make sure the assembly is stable.

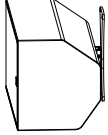

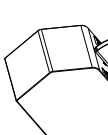
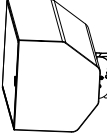
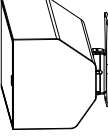
Wall-mounting X8i horizontally

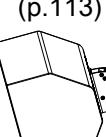
Overview

with pan?	site angle				
	0°	-5°	-15°	-40°	0° to -40°
no	<p>TILT-SUPPORT + WALL (p.91)</p> 	<p>TILT-SUPPORT + TILT5 (p.96)</p> 	<p>TILT-SUPPORT + TILT15 (p.96)</p> 	<p>TILT-SUPPORT + TILT40 (p.96)</p> 	<p>TILT-SUPPORT + TILT (p.101)</p> 
yes	<p>TILT-SUPPORT + PAN (p.108)</p> 	<p>TILT-SUPPORT + PAN + TILT5 (p.113)</p> 	<p>TILT-SUPPORT + PAN + TILT15 (p.113)</p> 	<p>TILT-SUPPORT + PAN + TILT40 (p.113)</p> 	<p>TILT-SUPPORT + PAN + TILT (p.121)</p> 

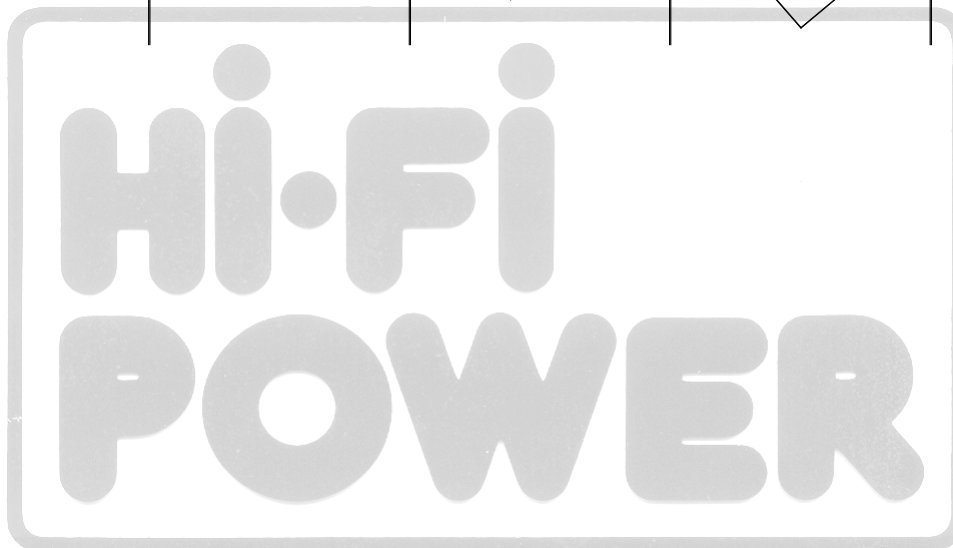

Wall-mounting X8i horizontally with WALL

Type of deployment	wall-mounting
Rigging accessories	TILT-SUPPORT
	WALL
Additional material	3 compatible screws and anchors
Tools	torque screwdriver
	T20 Torx bit
	T30 Torx bit
	8 mm wrench or 8 mm hex socket
Min. number of operators	1

Secondary safety for flown, wall-mounted, or ceiling-mounted enclosures

Use one insert at the back of the enclosure to implement a secondary safety.

Risk of crushing injury

Ensure that the wall or ceiling can support the load of the product.

It is recommended to mount only on solid structures. If mounting on a hollow structure (such as a wall cavity), place anchoring points on the framework (wall studs, ceiling joists), or reinforce the mounting area.

Select screws and anchors applicable to the wall or ceiling properties and to the load of the product. Prevent screws from loosening over time, using for example thread locker or lock washers.

Specifications for screws and anchors

deployment	accessory	ultimate tensile load per screw (daN)	ultimate shear load per screw (daN)	screws quantity	mounting hole size	specific constraints
wall-mounting	TILT-SUPPORT + any accessory	12	9	3	Ø 6.4 mm / 0.25 in (slotted)	–

Screws and fasteners

from TILT-SUPPORT



M5 hex locknut thick plain washer Ø 5 mm

from WALL

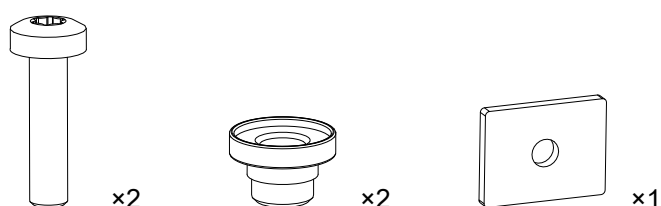

M6×25 Torx M5 tapered spacer rectangular washer

Assembly

Prerequisite

Place X8i on its front face on a clean flat surface.

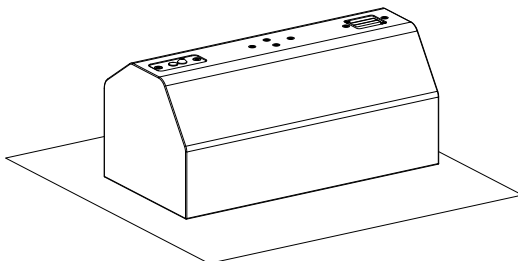

Make sure that the WALL safety screw is present and loosened.

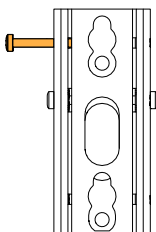

Procedure

! Make sure to leave enough space between the walls and the sides of the rigging element to access the screw(s) when the enclosure is mounted.

1. Drill holes in the wall for TILT-SUPPORT.

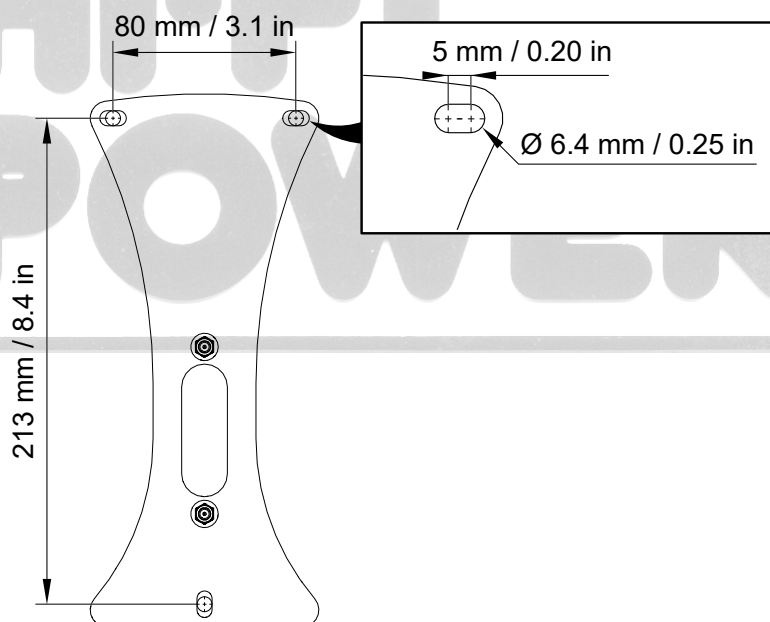

2. Assemble the wall-mounting plate and tapered spacers with TILT-SUPPORT.

Use the two M5 nuts.

The wall-mounting plate gasket is facing away from TILT-SUPPORT.

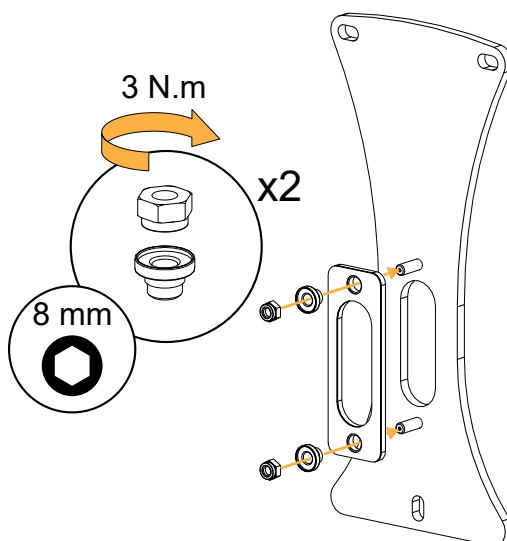

3. Secure TILT-SUPPORT and the wall-mounting plate to the wall.

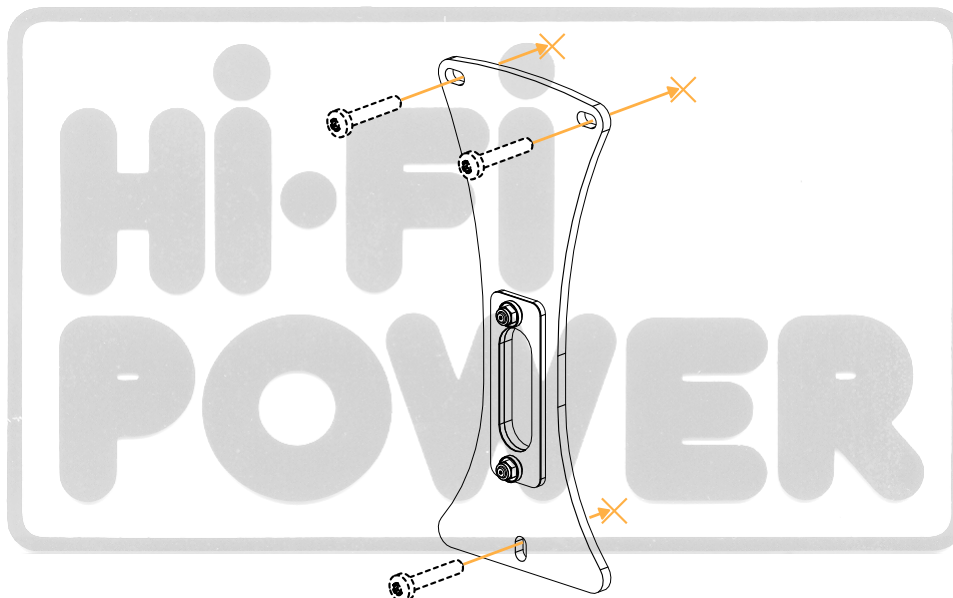

4. Remove the two placeholder screws in the middle of X8i.

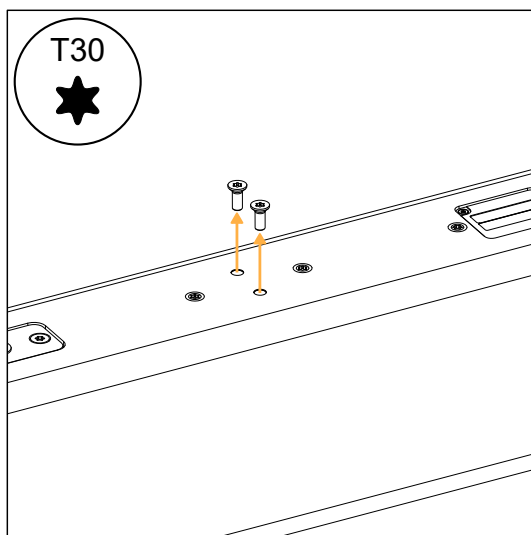

5. Insert the rectangular washer into WALL.



Make sure the rectangular washer is in the correct position.

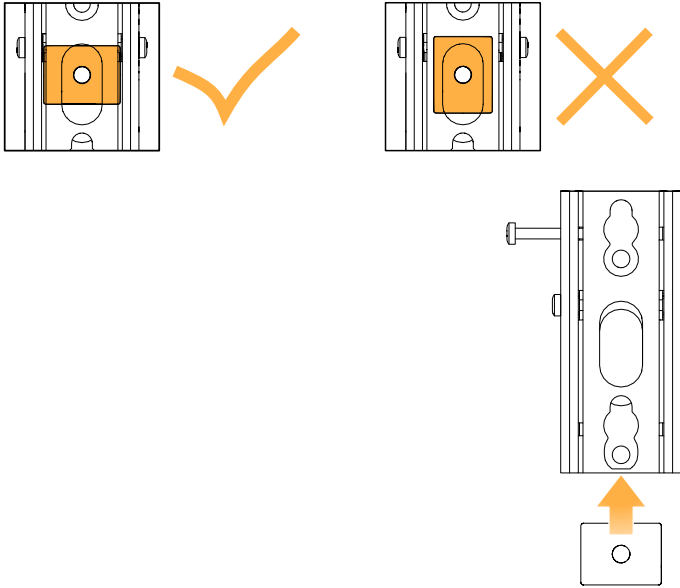

6. Secure WALL to X8i.

Use the two M6×25 Torx screws.



Align the top and the middle hole (formed by the washer) from the rigging accessory with the top and bottom hole on X8i, respectively.

Make sure that the safety screw is at the top when the enclosure is mounted in its final position.

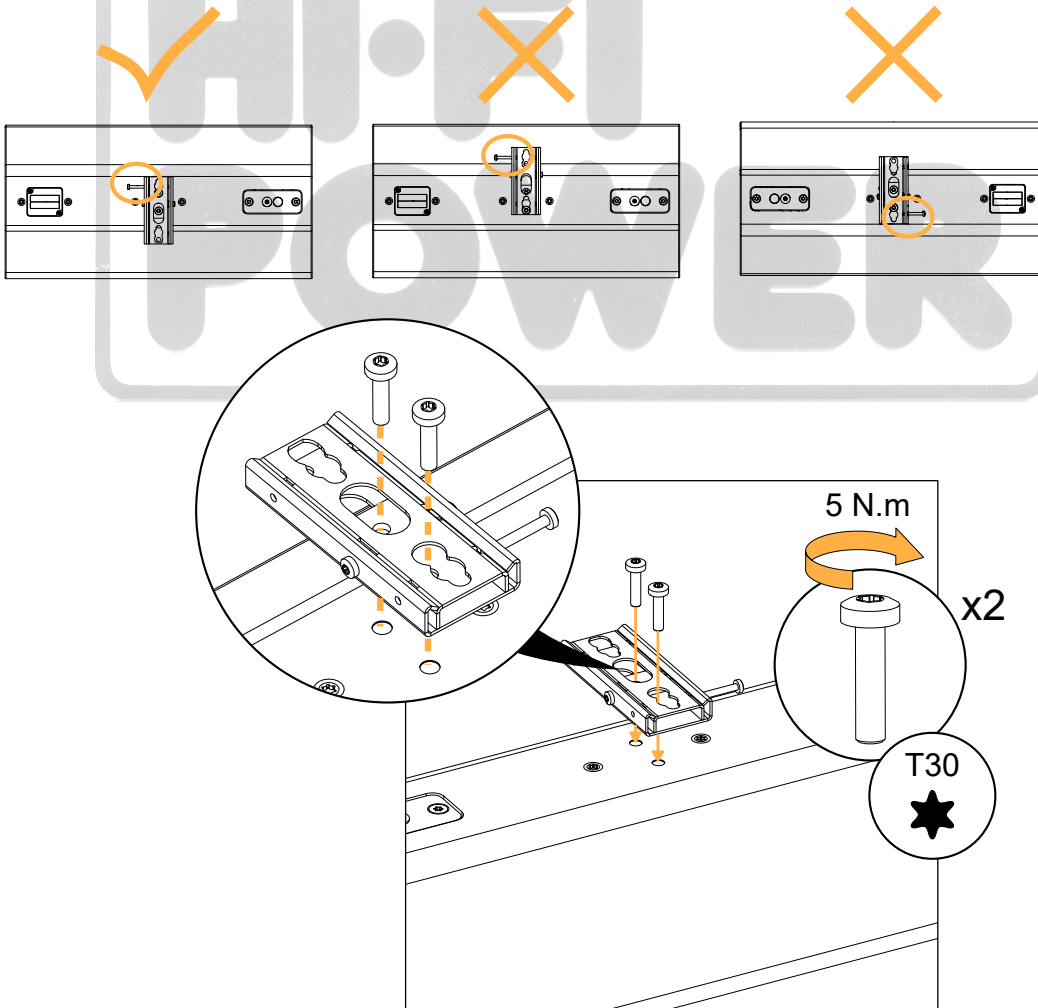

7. Prepare the cabling. Refer to [Cabling X8i](#) (p.171).

8. Mount the assembly on the wall-mounting plate:
- Align the midpoints of the WALL rear cutouts with the tapered spacers.
 - Push the assembly downwards.

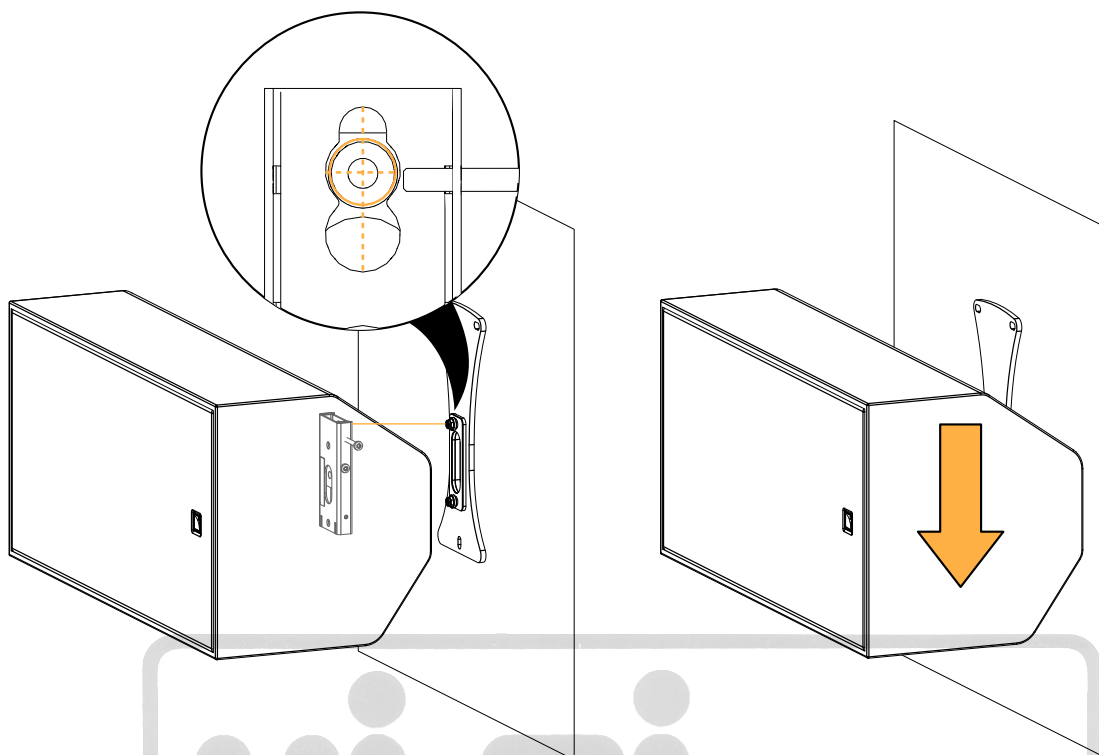

9. Tighten the safety screw and make sure the assembly is stable.

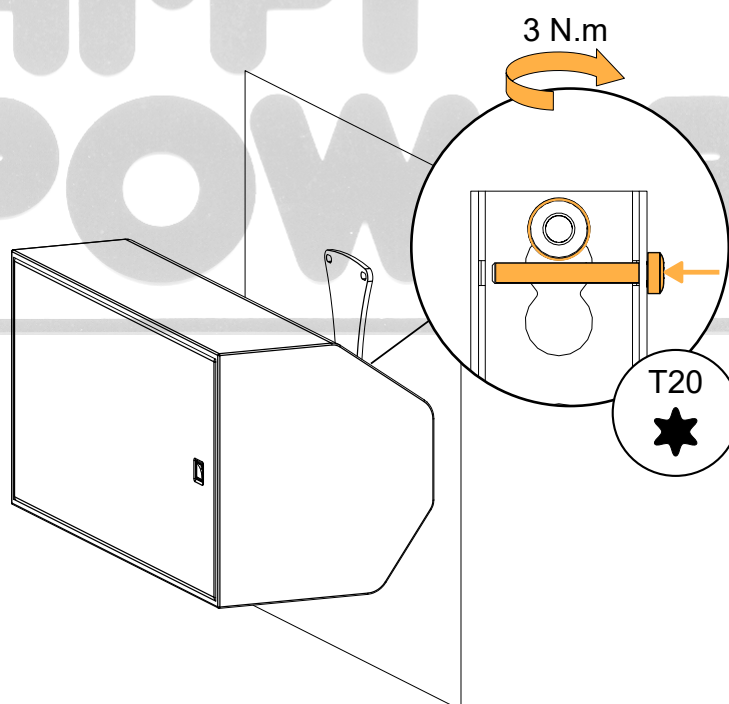

Wall-mounting X8i horizontally with TILT5/TILT15/TILT40

Type of deployment	wall-mounting
Rigging accessories	TILT-SUPPORT
	TILT5/TILT15/TILT40
Additional material	3 compatible screws and anchors
Tools	torque screwdriver
	screwdriver extension or angled screwdriver
	T30 Torx bit
	8 mm wrench or 8 mm hex socket
Min. number of operators	1

! Secondary safety for flown, wall-mounted, or ceiling-mounted enclosures
Use one insert at the back of the enclosure to implement a secondary safety.

! Risk of crushing injury
Ensure that the wall or ceiling can support the load of the product.
It is recommended to mount only on solid structures. If mounting on a hollow structure (such as a wall cavity), place anchoring points on the framework (wall studs, ceiling joists), or reinforce the mounting area.
Select screws and anchors applicable to the wall or ceiling properties and to the load of the product. Prevent screws from loosening over time, using for example thread locker or lock washers.

Specifications for screws and anchors

deployment	accessory	ultimate tensile load per screw (daN)	ultimate shear load per screw (daN)	screws quantity	mounting hole size	specific constraints
wall-mounting	TILT-SUPPORT + any accessory	12	9	3	Ø 6.4 mm / 0.25 in (slotted)	–

! Risk of falling objects
Do not use TILT, TILT5, TILT15, or TILT40 upside-down. These rigging accessories are designed for negative site angles only.

Screws and fasteners**from TILT-SUPPORT**

x2

M5 hex locknut

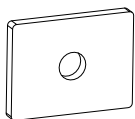
from TILT5/TILT15/TILT40

x1

rectangular washer

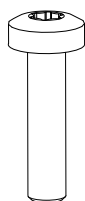

x2

M6x25 Torx

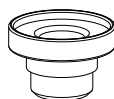

x2

M5 tapered spacer

Assembly

About this task



In this procedure, TILTxx designates the fixed angle accessories TILT5, TILT15, and TILT40.

Prerequisite

Place X8i on its front face on a clean flat surface.

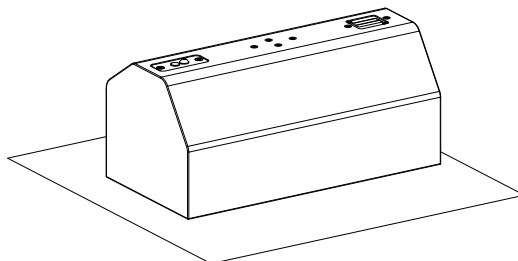

Make sure that the TILTxx safety screw is present and loosened.

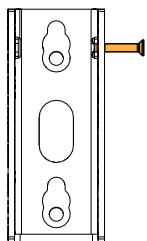

Procedure



Make sure to leave enough space between the walls and the sides of the rigging element to access the screw(s) when the enclosure is mounted.

1. Drill holes in the wall for TILT-SUPPORT.

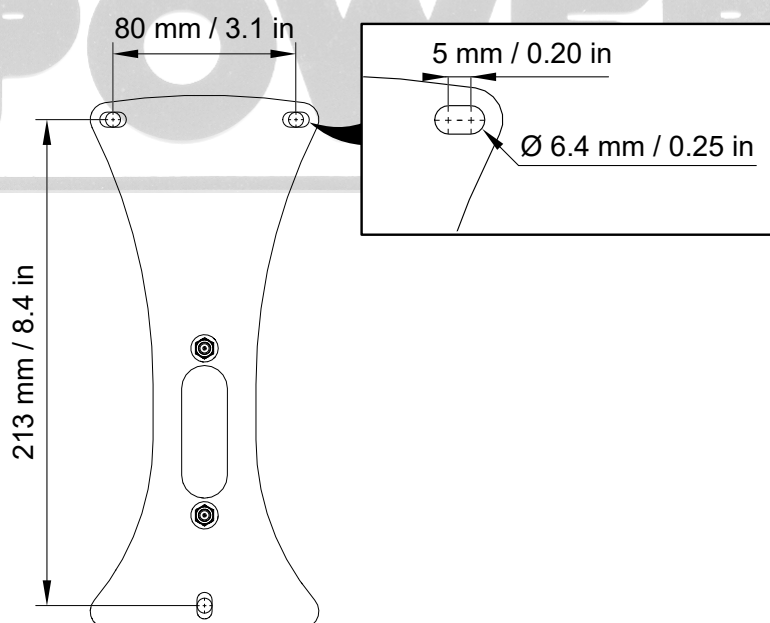

2. Assemble the wall-mounting plate and tapered spacers with TILT-SUPPORT.

Use the two M5 nuts.

The wall-mounting plate gasket is facing away from TILT-SUPPORT.

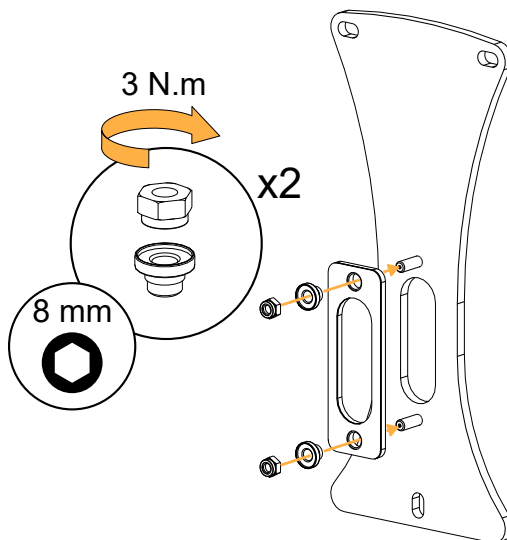

3. Secure TILT-SUPPORT and the wall-mounting plate to the wall.

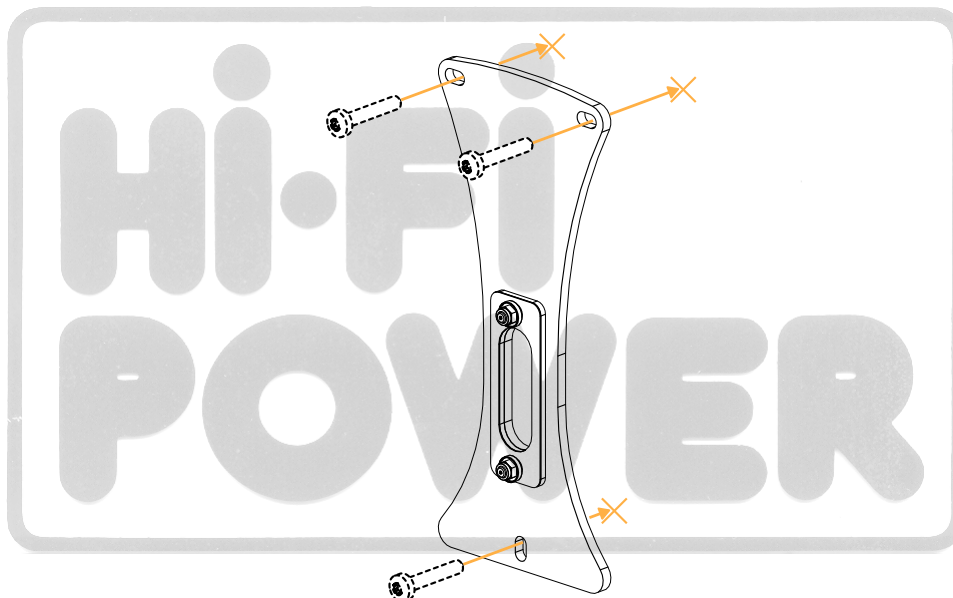

4. Remove the two placeholder screws in the middle of X8i.

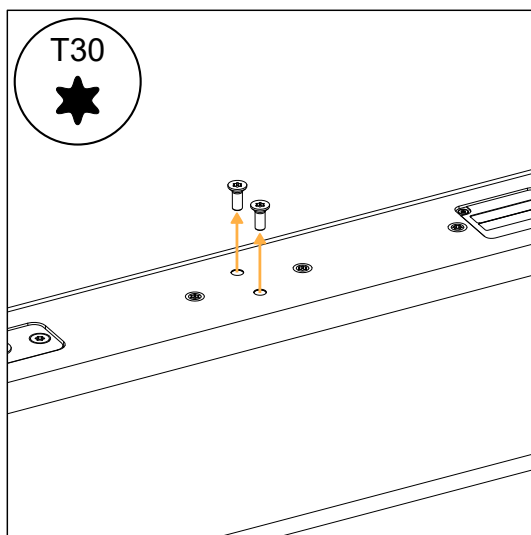

5. Insert the rectangular washer into TILTxx.

! Make sure the rectangular washer is in the correct position.

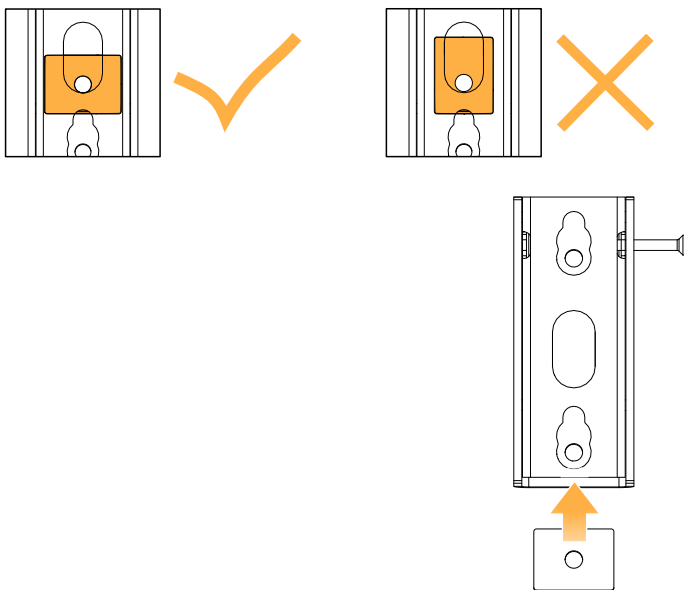

6. Secure TILTxx to X8i.

Use the two M6×25 Torx screws.

! Align the top and the middle hole (formed by the washer) from the rigging accessory with the top and bottom hole on X8i, respectively. Make sure that the safety screw is at the top when the enclosure is mounted in its final position.

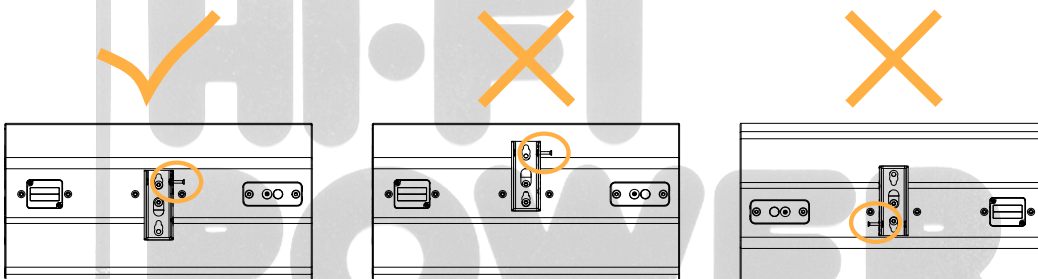

i If the shank of the screwdriver collides with TILT40, use a screwdriver extension or an angled screwdriver to drive the screws.

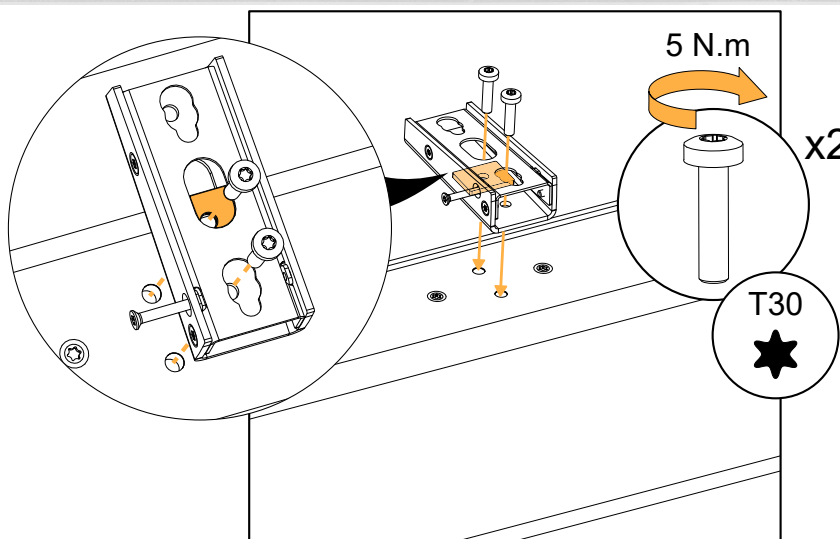

7. Prepare the cabling. Refer to [Cabling X8i](#) (p.171).

8. Mount the assembly on the wall-mounting plate:
- a) Align the TILTxx holes with the tapered spacers.
 - b) Push the assembly downwards.

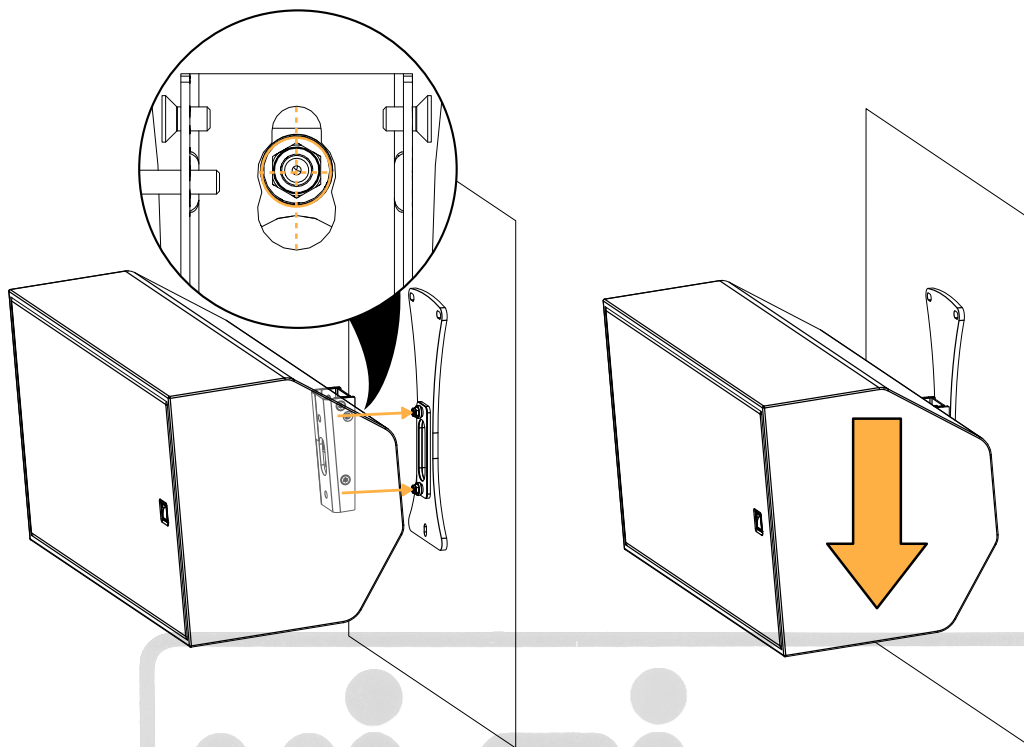

9. Tighten the safety screw.
Make sure the assembly is stable.

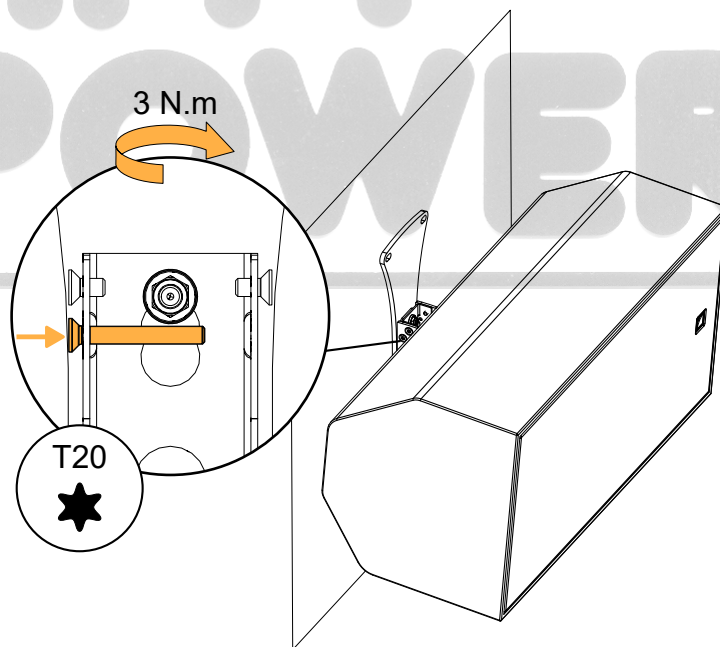

Wall-mounting X8i horizontally with TILT

Type of deployment	wall-mounting
Rigging accessories	TILT-SUPPORT
	TILT
Additional material	3 compatible screws and anchors
Tools	torque screwdriver
	T20 Torx bit
	T30 Torx bit
	8 mm wrench or 8 mm hex socket
Min. number of operators	1

! Assembly overview

Pay attention to the position of the accessory parts throughout the procedure.



! Secondary safety for flown, wall-mounted, or ceiling-mounted enclosures

Use one insert at the back of the enclosure to implement a secondary safety.

! Risk of crushing injury

Ensure that the wall or ceiling can support the load of the product.

It is recommended to mount only on solid structures. If mounting on a hollow structure (such as a wall cavity), place anchoring points on the framework (wall studs, ceiling joists), or reinforce the mounting area.

Select screws and anchors applicable to the wall or ceiling properties and to the load of the product. Prevent screws from loosening over time, using for example thread locker or lock washers.

Specifications for screws and anchors

deployment	accessory	ultimate tensile load per screw (daN)	ultimate shear load per screw (daN)	screws quantity	mounting hole size	specific constraints
wall-mounting	TILT-SUPPORT + any accessory	12	9	3	Ø 6.4 mm / 0.25 in (slotted)	–

! Risk of falling objects

Do not use TILT, TILT5, TILT15, or TILT40 upside-down. These rigging accessories are designed for negative site angles only.

Screws and fasteners

from TILT-SUPPORT



x2



x2

M5 hex locknut

thick plain washer Ø
5 mm

from TILT

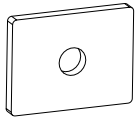

x1

rectangular washer

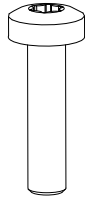

x2

M6x25 Torx



x1

M4x16 Torx
(pre-mounted)



x1

Axis with M4
Torx head (pre-
mounted)

Hi-Fi
POWER

Assembly

About this task

Prerequisite

Place X8i on its front face on a clean flat surface.

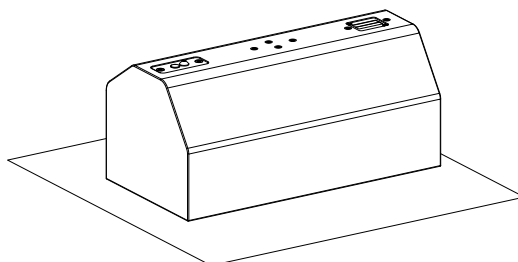

Procedure



Make sure to leave enough space between the walls and the sides of the rigging element to access the screw(s) when the enclosure is mounted.

1. Drill holes in the wall for TILT-SUPPORT.

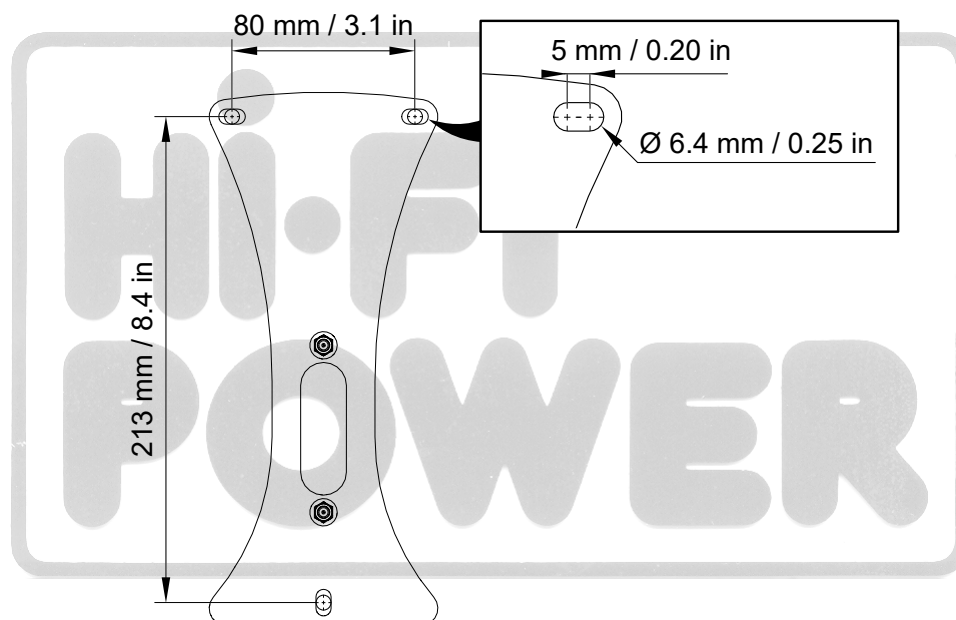

2. Disassemble the two TILT parts.

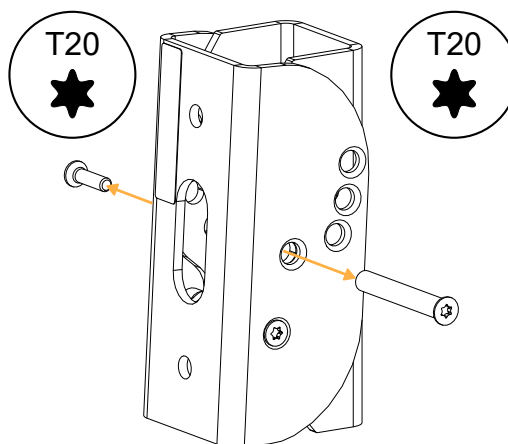

3. Assemble the TILT wall-mounting part with TILT-SUPPORT.

Use the two M5 nuts and washers.

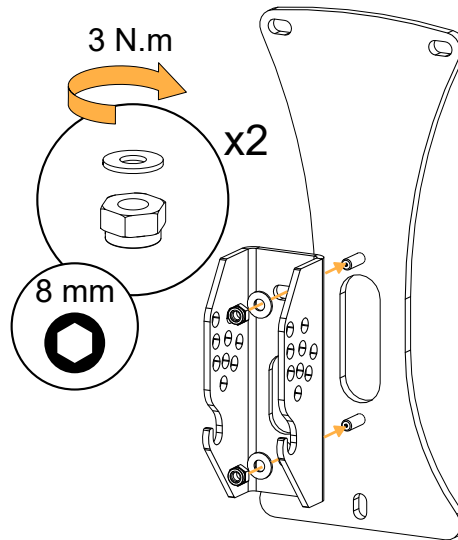

4. Secure TILT-SUPPORT and TILT to the wall.

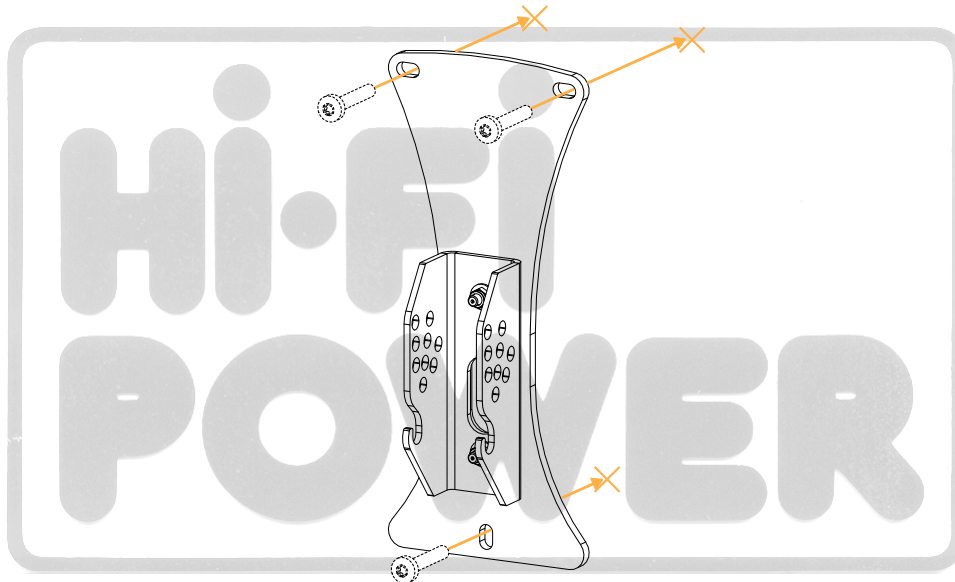

5. Secure TILT to X8i:

- a) Remove the two placeholder screws in the middle of X8i.
- b) Secure the TILT enclosure-mounting part with the rectangular washer to X8i.

Use the two M6×25 Torx screws.

! Align the top and the middle hole (formed by the washer) from the rigging accessory with the top and bottom hole on X8i, respectively.

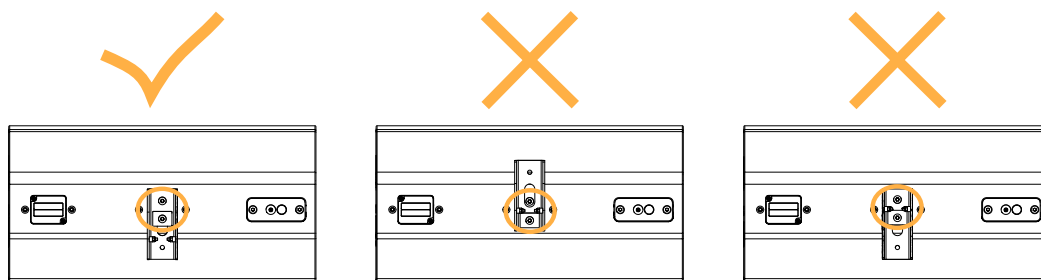

! Make sure the rectangular washer is in the correct position.

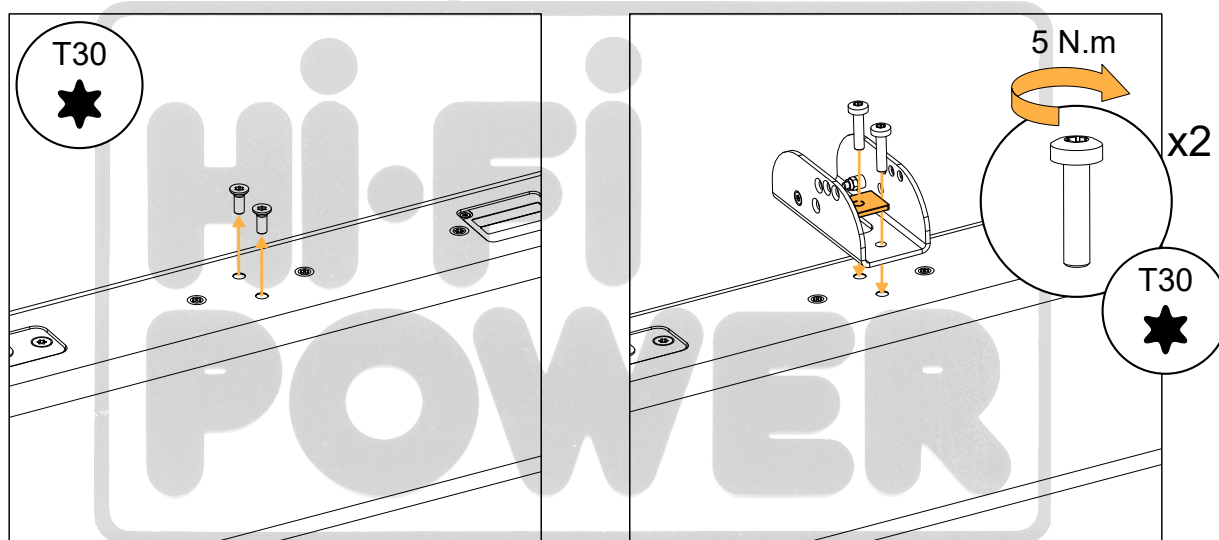
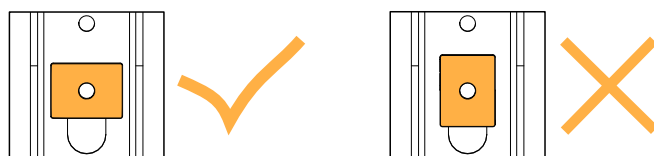

6. Prepare the cabling. Refer to [Cabling X8i](#) (p.171).



Risk of pinching fingers

Hold X8i from underneath when assembling the two TILT parts.

7. Mount X8i on the wall:

- a) Assemble the two TILT parts by fitting the indexing studs into the hooks. Make sure the studs are pushed all the way into the hooks.

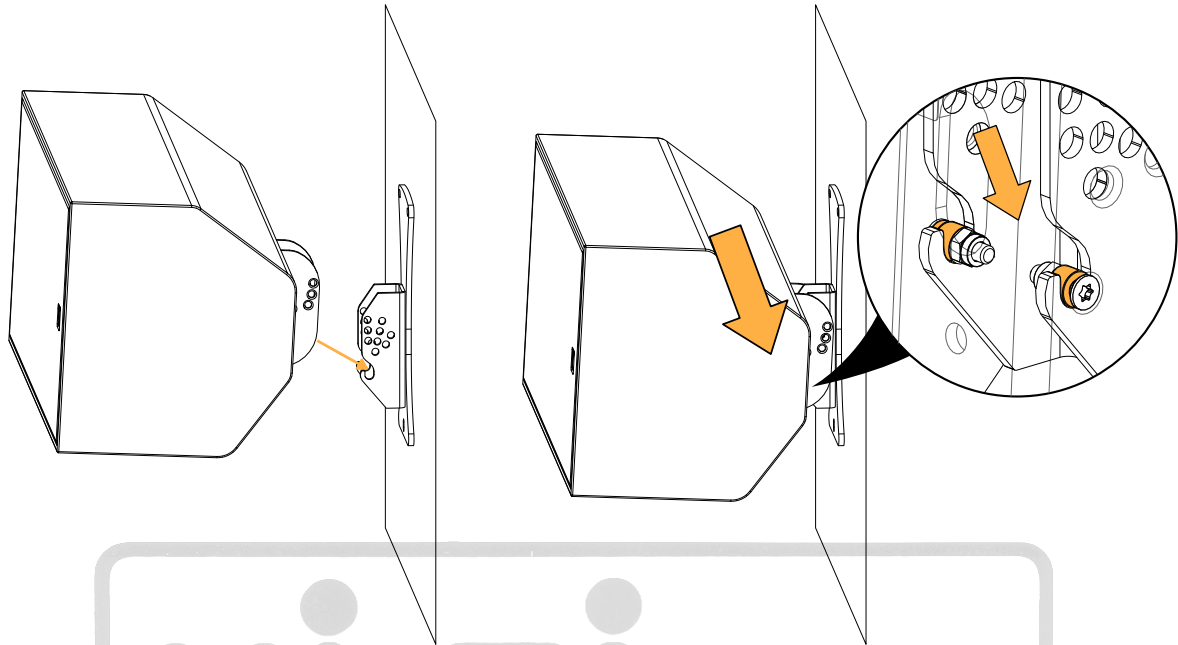

- b) Rotate the assembly to select the site angle.

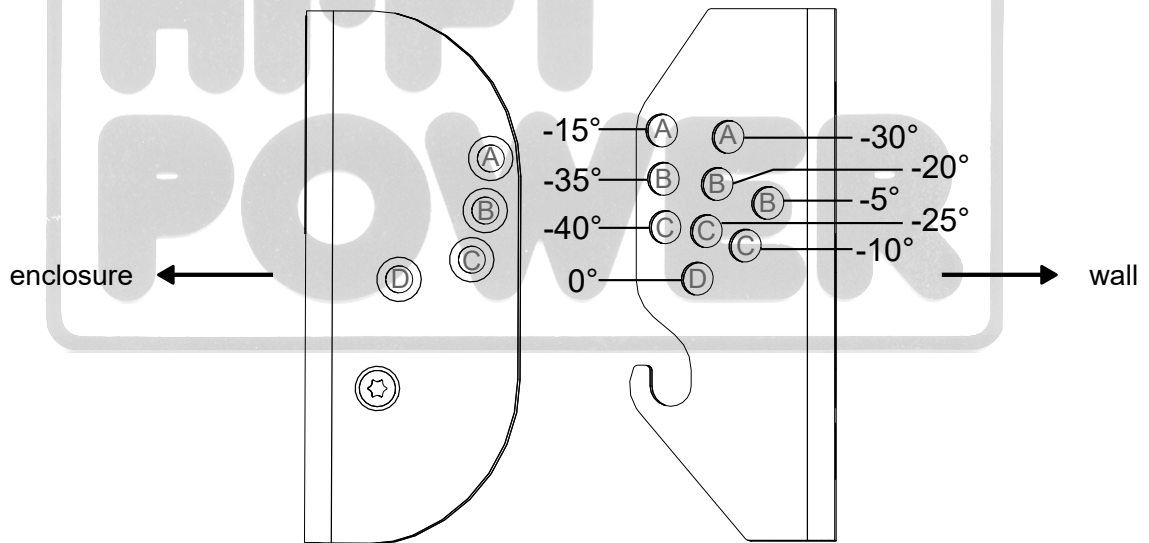

- c) Drive the axis through the holes and secure it with the M4×16 Torx screw.
Make sure the assembly is stable.

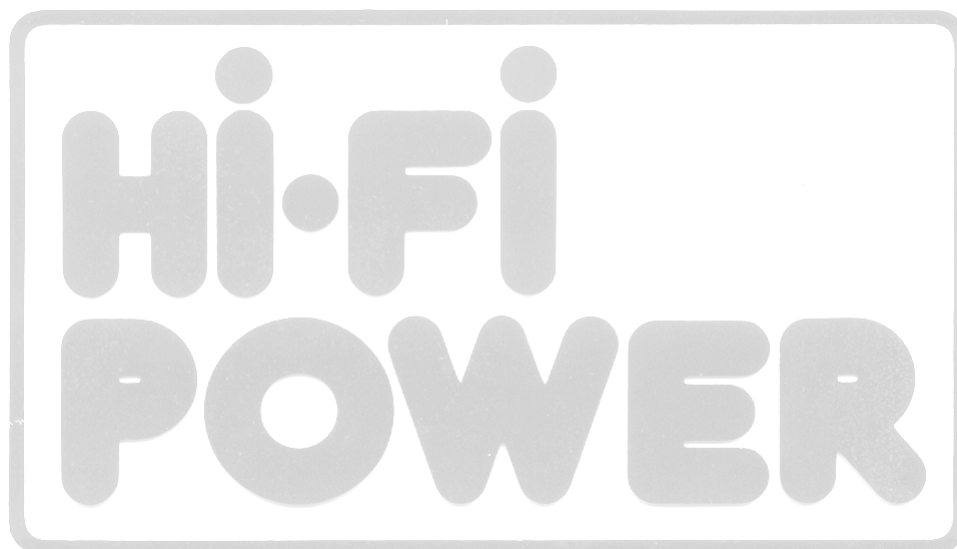
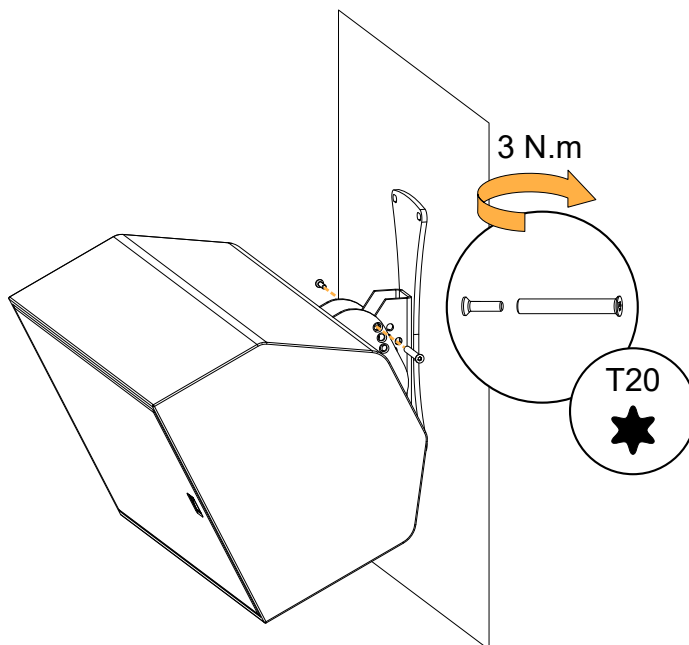

Wall-mounting X8i horizontally with PAN

Type of deployment	wall-mounting
Rigging accessories	TILT-SUPPORT
	PAN
Additional material	3 compatible screws and anchors
Tools	torque screwdriver
	T30 Torx bit
	T40 Torx bit
	8 mm wrench or 8 mm hex socket
Min. number of operators	1

! Assembly overview

Pay attention to the position of the accessory parts throughout the procedure.

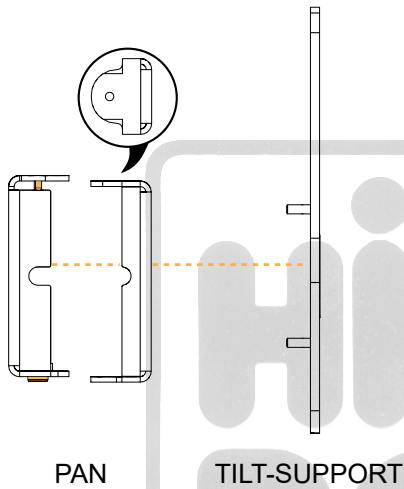
**! Secondary safety for flown, wall-mounted, or ceiling-mounted enclosures**

Use one insert at the back of the enclosure to implement a secondary safety.

! Risk of crushing injury

Ensure that the wall or ceiling can support the load of the product.

It is recommended to mount only on solid structures. If mounting on a hollow structure (such as a wall cavity), place anchoring points on the framework (wall studs, ceiling joists), or reinforce the mounting area.

Select screws and anchors applicable to the wall or ceiling properties and to the load of the product. Prevent screws from loosening over time, using for example thread locker or lock washers.

Specifications for screws and anchors

deployment	accessory	ultimate tensile load per screw (daN)	ultimate shear load per screw (daN)	screws quantity	mounting hole size	specific constraints
wall-mounting	TILT-SUPPORT + any accessory	12	9	3	Ø 6.4 mm / 0.25 in (slotted)	–

! Risk of falling objects

Do not use PAN or PANx2 upside-down.

Do not swap the wall-mounting part(s) and the enclosure-mounting part(s).

Screws and fasteners

from TILT-SUPPORT



M5 hex locknut thick plain washer Ø
5 mm

from PAN

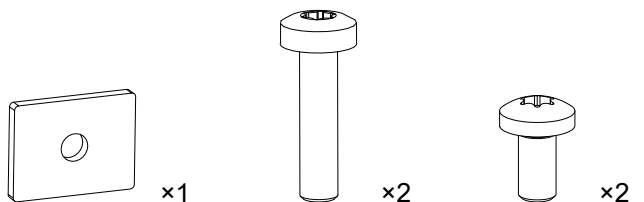

rectangular washer M6x25 Torx M8x16 Torx

Assembly

Prerequisite

Place X8i on its front face on a clean flat surface.

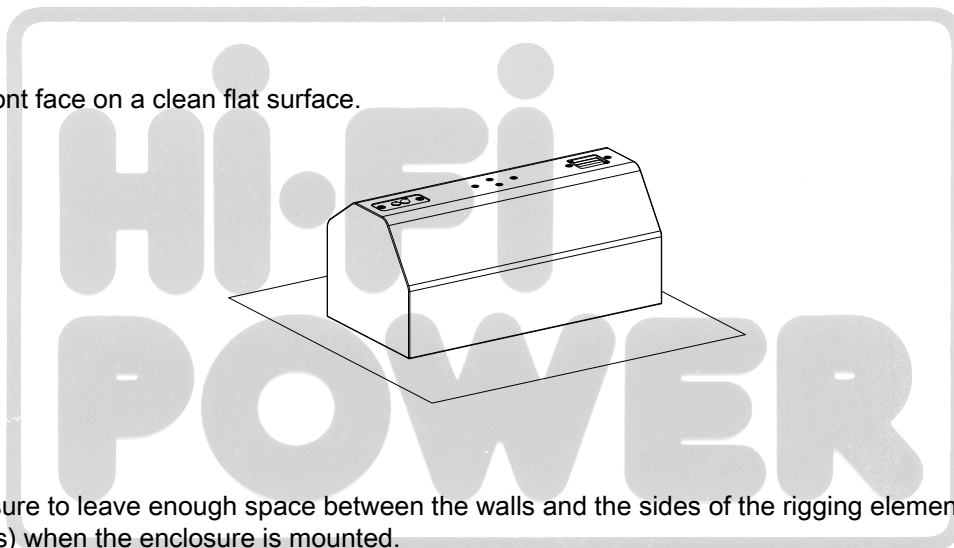

Procedure

! Make sure to leave enough space between the walls and the sides of the rigging element to access the screw(s) when the enclosure is mounted.

1. Drill holes in the wall for TILT-SUPPORT.

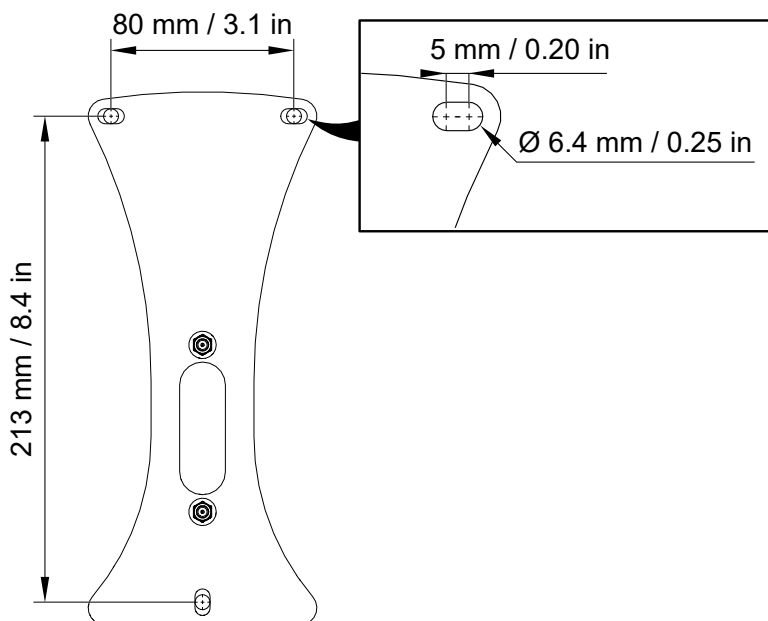

2. Assemble the PAN wall-mounting part with TILT-SUPPORT.

Use the two M5 nuts and washers.

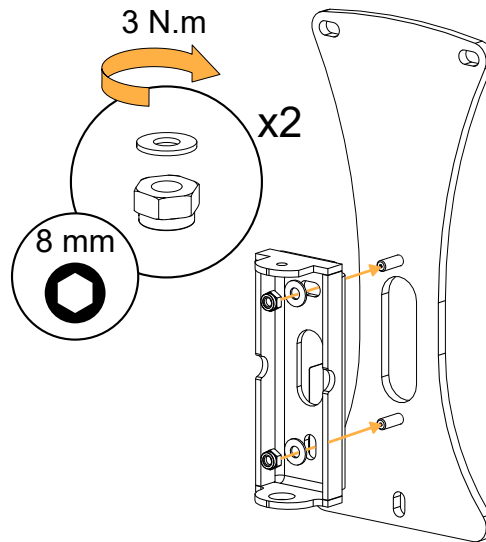

3. Secure TILT-SUPPORT and PAN to the wall.

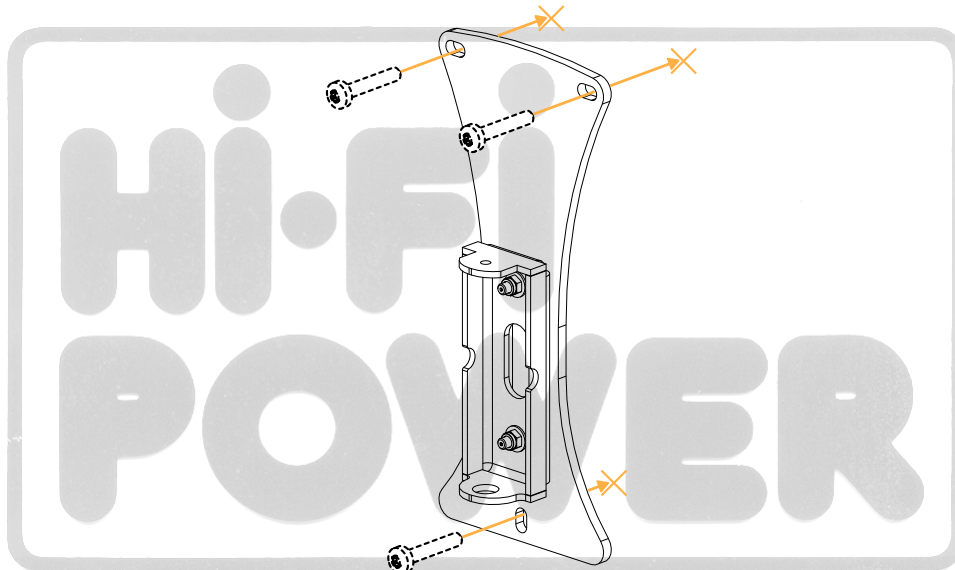

4. Secure PAN to X8i:

- a) Remove the two placeholder screws in the middle of X8i.
 - b) Secure the PAN enclosure-mounting part with the rectangular washer to X8i.
- Use the two M6×25 Torx screws.

! Make sure the rectangular washer is in the correct position.

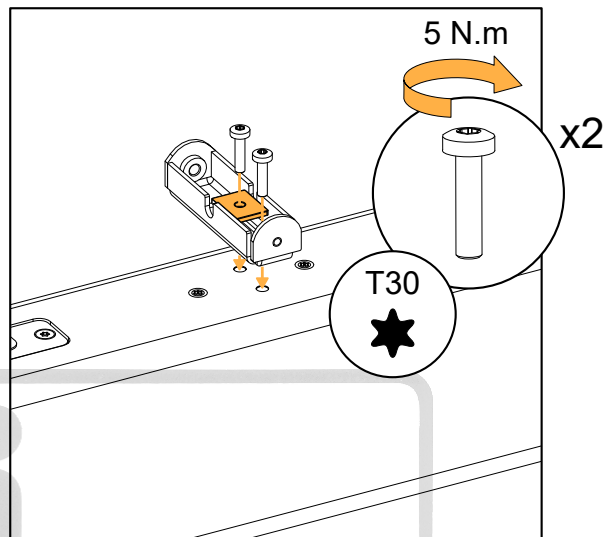
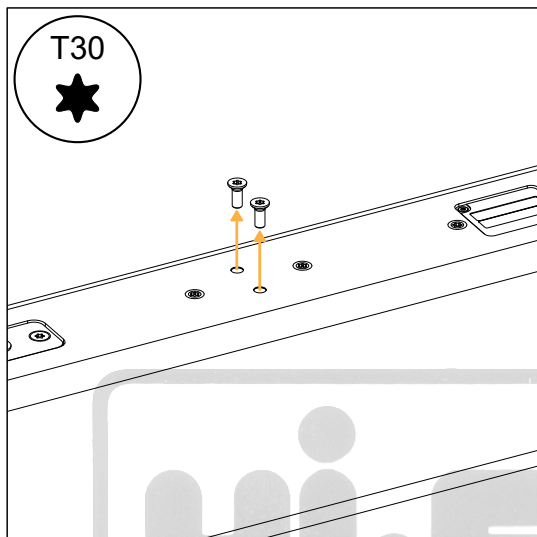
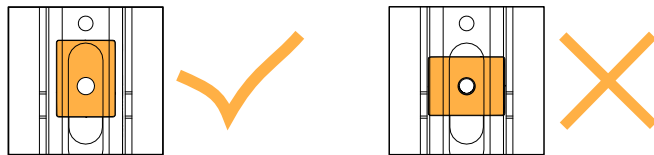

5. Prepare the cabling. Refer to [Cabling X8i](#) (p.171).

6. Mount the assembly on the PAN wall-mounting part:

- a) Align the pin with the top hole and push the assembly downwards.
- b) Drive the M8×16 Torx screw from underneath PAN.

! Do not fully tighten the screw.

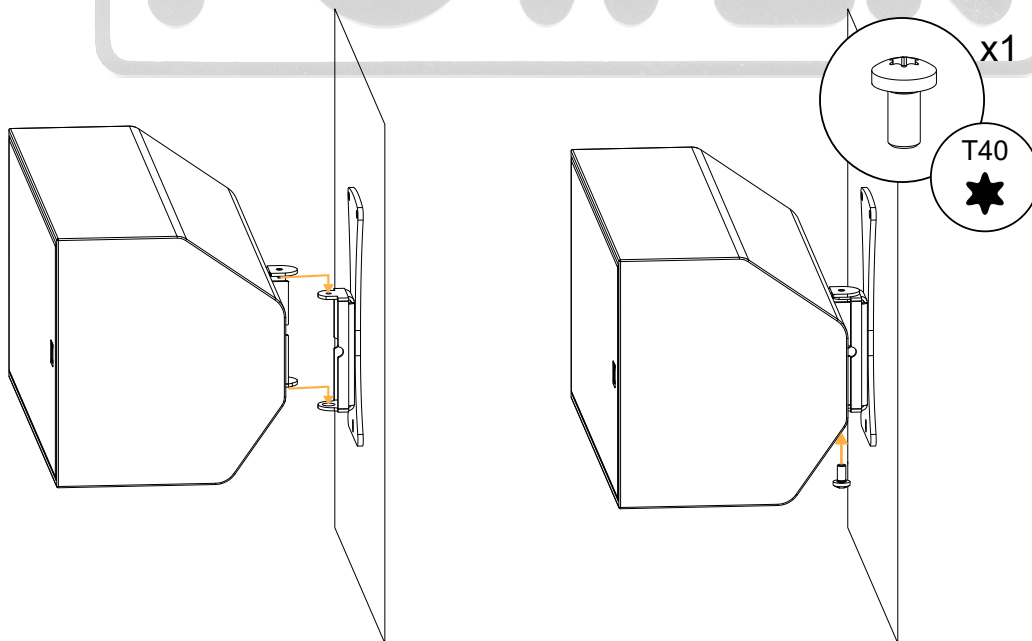

7. Rotate the assembly to adjust the azimuth angle.



Azimuth angle in horizontal orientation

When X8i is mounted horizontally with PAN against a wall, an azimuth angle of $+9^{\circ}/-9^{\circ}$ can be reached. Use a wedge or mount on a narrow wall to increase the azimuth angle, up to $+45^{\circ}/-45^{\circ}$.

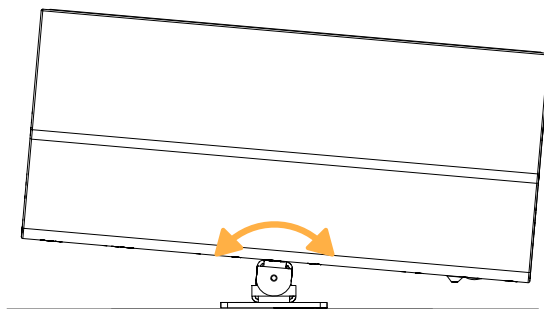

8. Tighten the M8 screw. Apply a torque of 10 N.m.

Make sure the assembly is stable.

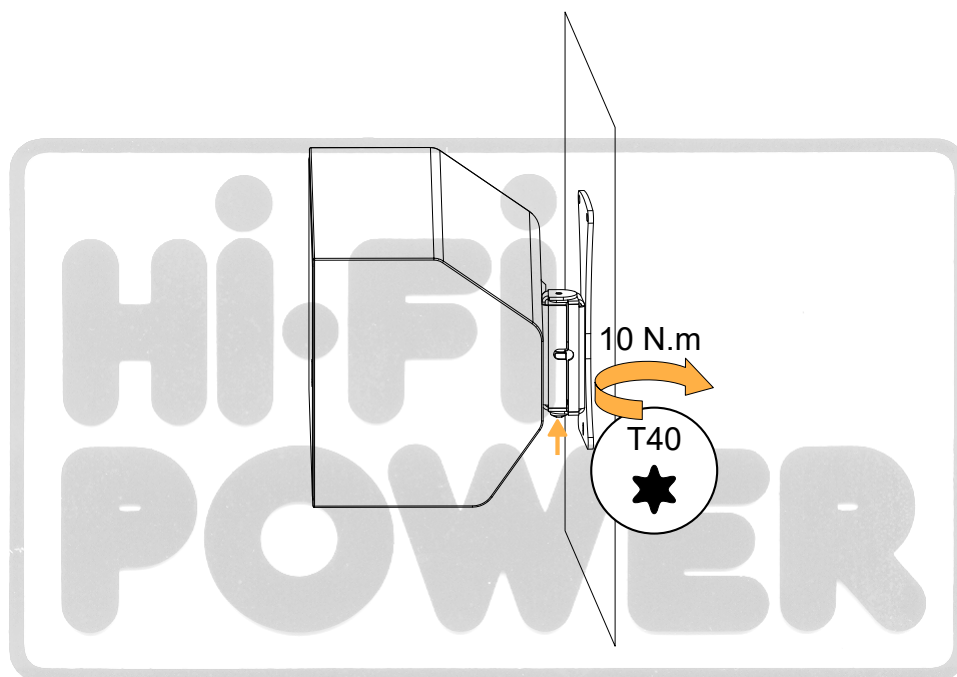

Wall-mounting X8i horizontally with PAN and TILT5/TILT15/TILT40

Type of deployment	wall-mounting
Rigging accessories	TILT-SUPPORT
	PAN
	TILT5/TILT15/TILT40
Additional material	3 compatible screws and anchors
Tools	torque screwdriver
	T25 Torx bit
	T30 Torx bit
	T40 Torx bit
	8 mm wrench or 8 mm hex socket
Min. number of operators	1

! Assembly overview

Pay attention to the position of the accessory parts throughout the procedure.

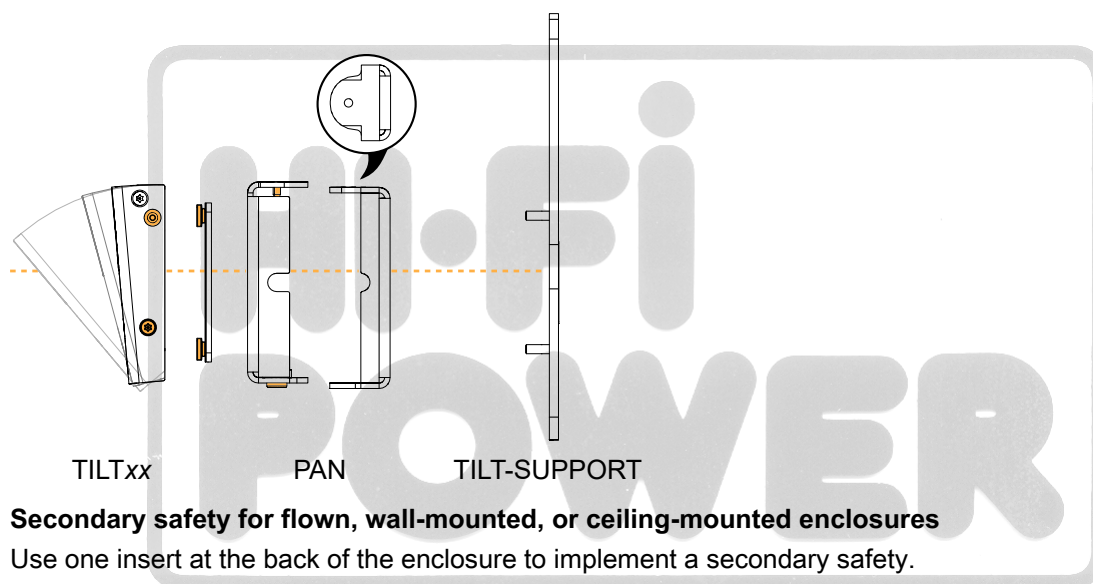

! Secondary safety for flown, wall-mounted, or ceiling-mounted enclosures

Use one insert at the back of the enclosure to implement a secondary safety.

! Risk of crushing injury

Ensure that the wall or ceiling can support the load of the product.

It is recommended to mount only on solid structures. If mounting on a hollow structure (such as a wall cavity), place anchoring points on the framework (wall studs, ceiling joists), or reinforce the mounting area.

Select screws and anchors applicable to the wall or ceiling properties and to the load of the product. Prevent screws from loosening over time, using for example thread locker or lock washers.

Specifications for screws and anchors

deployment	accessory	ultimate tensile load per screw (daN)	ultimate shear load per screw (daN)	screws quantity	mounting hole size	specific constraints
wall-mounting	TILT-SUPPORT + any accessory	12	9	3	Ø 6.4 mm / 0.25 in (slotted)	–

! Risk of falling objects

Do not use PAN or PANx2 upside-down.

Do not swap the wall-mounting part(s) and the enclosure-mounting part(s).

⚠ Risk of falling objects
Do not use TILT, TILT5, TILT15, or TILT40 upside-down. These rigging accessories are designed for negative site angles only.

Screws and fasteners

from TILT-SUPPORT

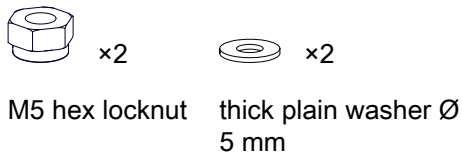

from PAN

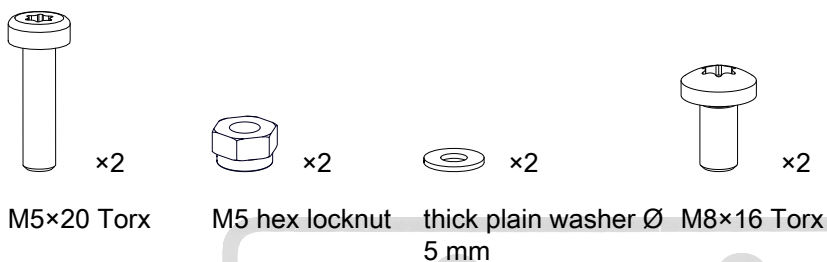

from TILT5/TILT15/TILT40

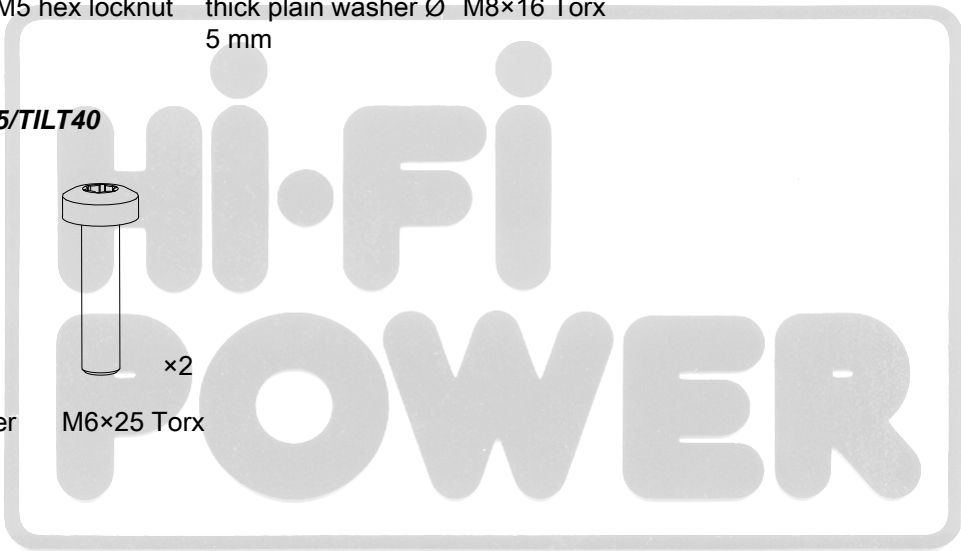
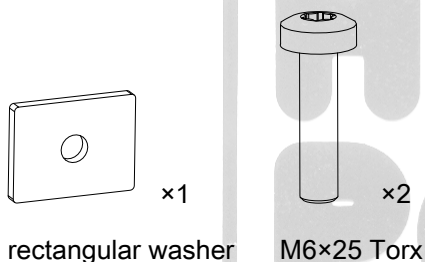

Assembly

About this task

i In this procedure, TILTxx designates the fixed angle accessories TILT5, TILT15, and TILT40.

Prerequisite

Place X8i on its front face on a clean flat surface.

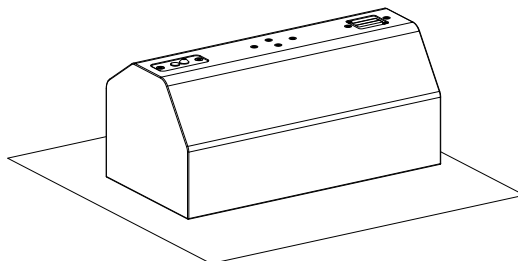

Make sure that the TILTxx safety screw is present and loosened.

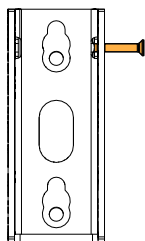

Procedure

! Make sure to leave enough space between the walls and the sides of the rigging element to access the screw(s) when the enclosure is mounted.

1. Drill holes in the wall for TILT-SUPPORT.

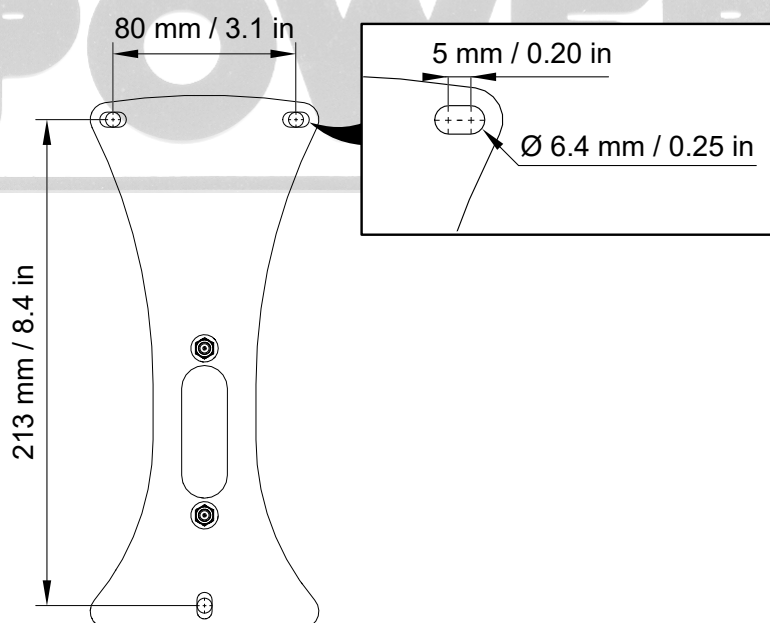

2. Assemble the PAN wall-mounting part with TILT-SUPPORT.

Use the two M5 nuts and washers.

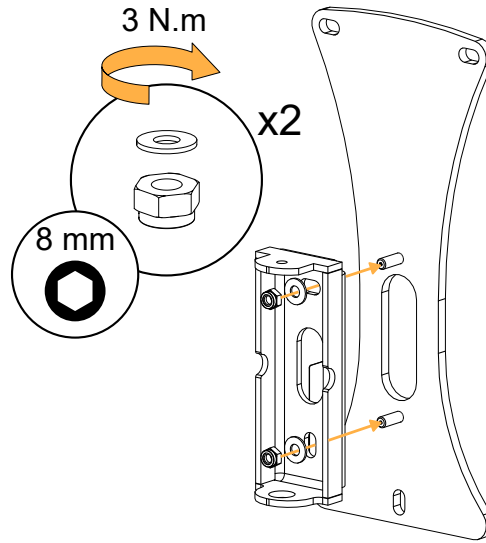

3. Secure TILT-SUPPORT and PAN to the wall.

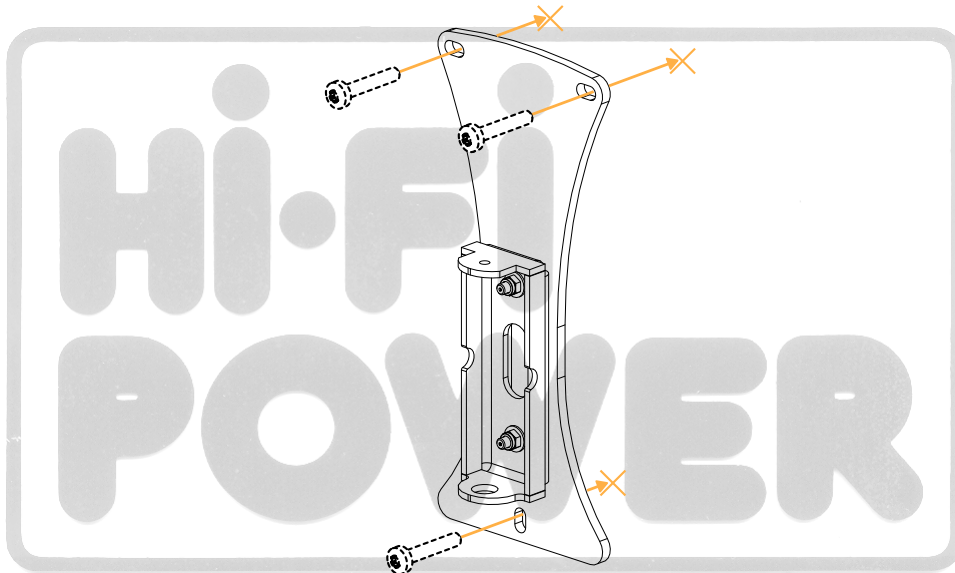

4. Assemble the wall-mounting plate and tapered spacers with PAN.

Use two M5×20 Torx screws, two M5 washers, and two M5 nuts.

The wall-mounting plate gasket is facing away from PAN.

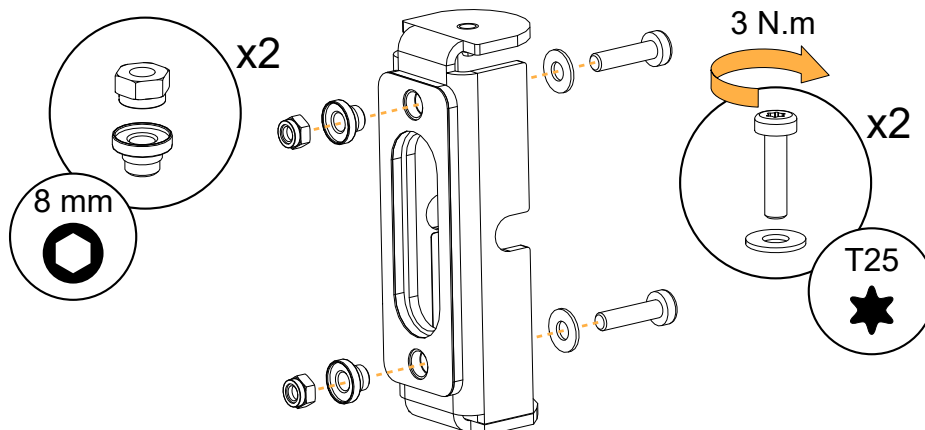

5. Mount the assembly on the PAN wall-mounting part:

- a) Align the pin with the top hole and push the assembly downwards.
- b) Drive the M8×16 Torx screw from underneath PAN.

 Do not fully tighten the screw.

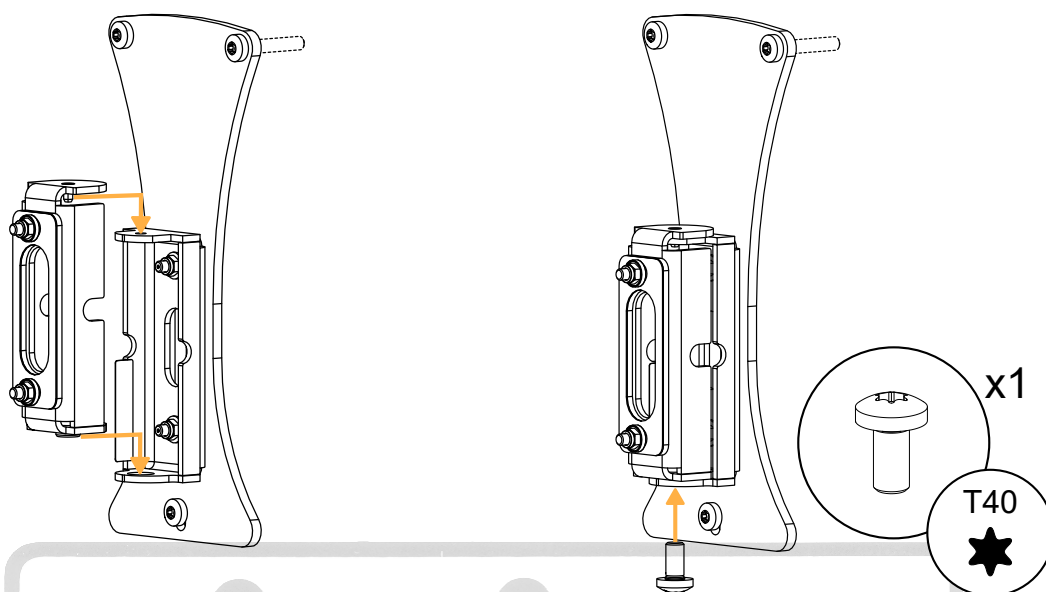

6. Remove the two placeholder screws in the middle of X8i.

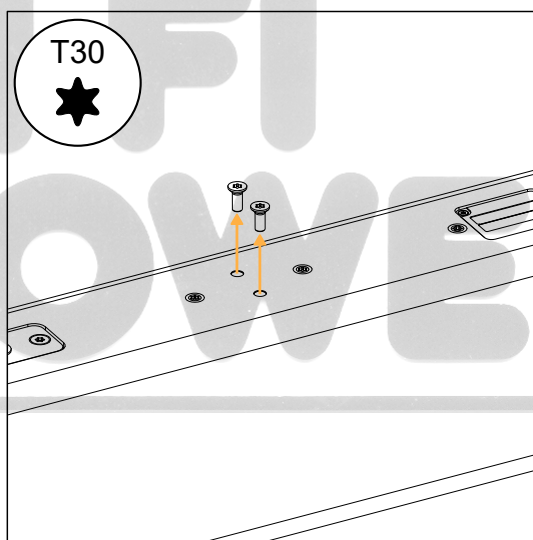

7. Insert the rectangular washer into TILTxx.



Make sure the rectangular washer is in the correct position.

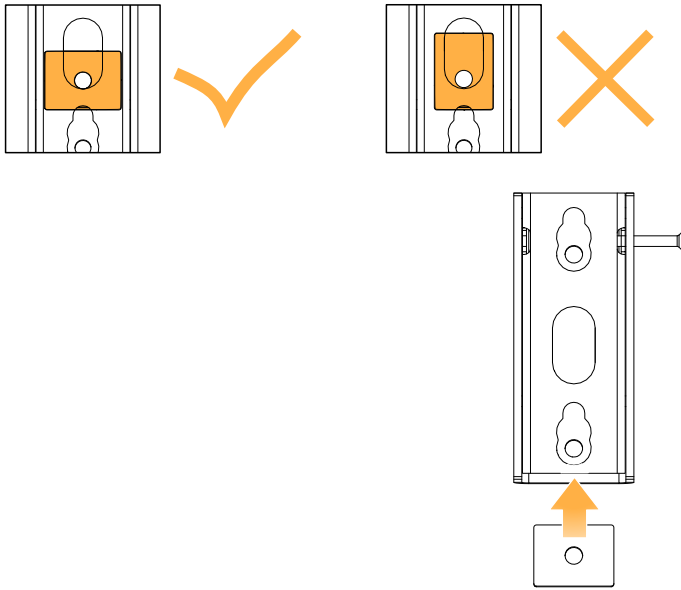

8. Secure TILTxx to X8i.

Use the two M6×25 Torx screws.



Align the top and the middle hole (formed by the washer) from the rigging accessory with the top and bottom hole on X8i, respectively.

Make sure that the safety screw is at the top when the enclosure is mounted in its final position.

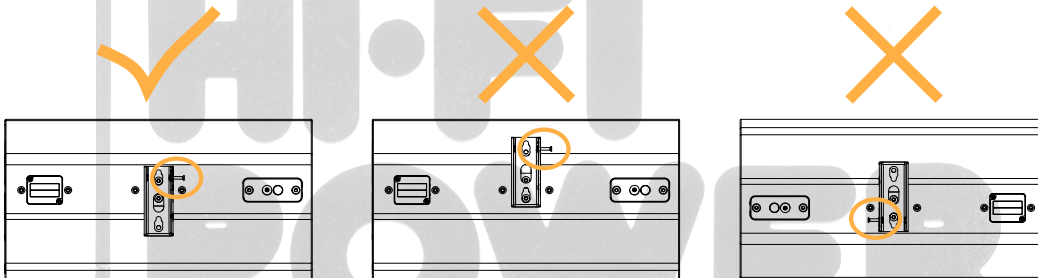

If the shank of the screwdriver collides with TILT40, use a screwdriver extension or an angled screwdriver to drive the screws.

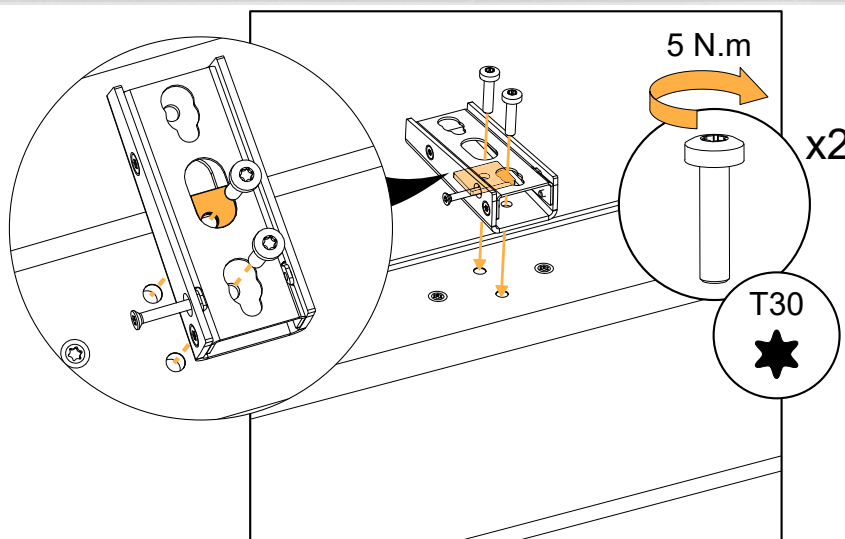

9. Prepare the cabling. Refer to [Cabling X8i](#) (p.171).

10. Mount X8i on PAN:

- a) Align the midpoints of the TILTxx rear cutouts with the tapered spacers.
- b) Push the assembly downwards.

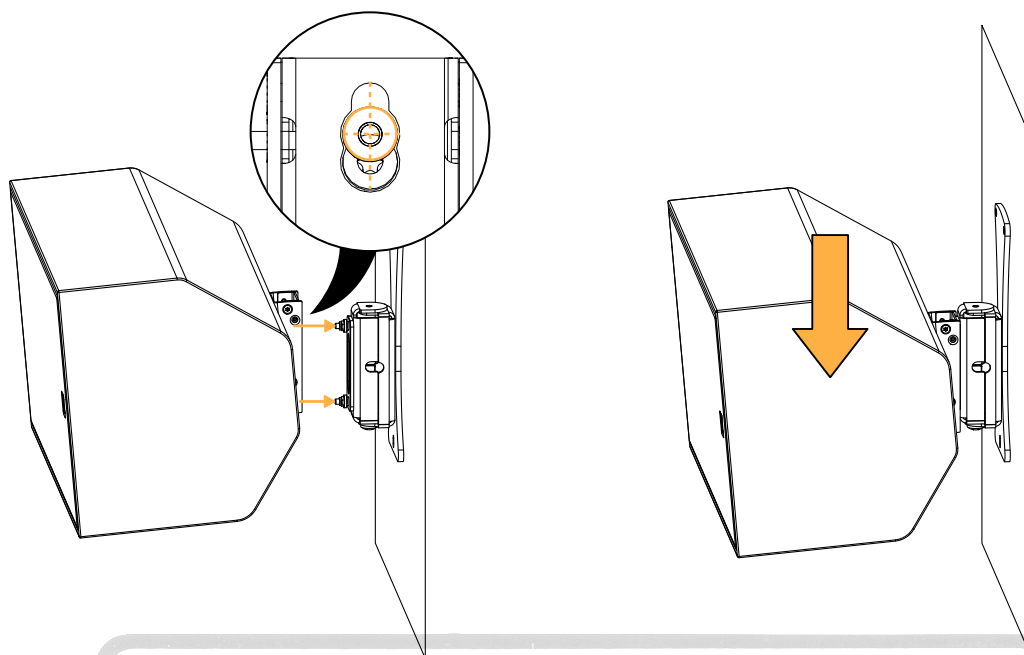
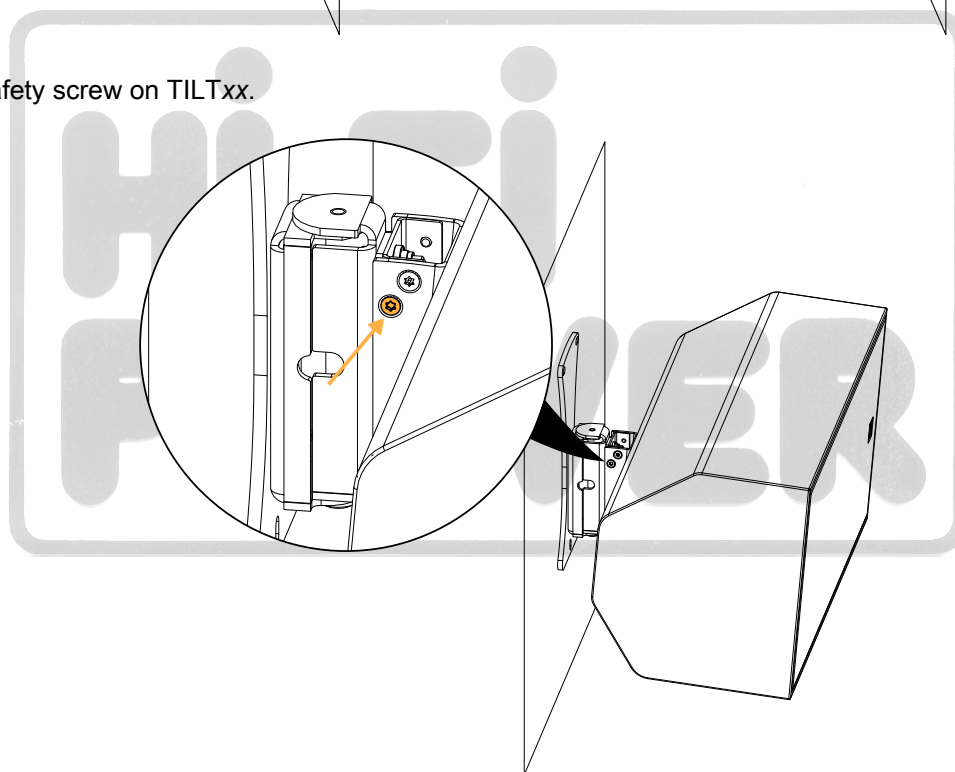
**11. Tighten the safety screw on TILTxx.**

12. Rotate the assembly to adjust the azimuth angle.



Azimuth angle in horizontal orientation

When X8i is mounted horizontally with PAN against a wall, an azimuth angle of $+9^{\circ}/-9^{\circ}$ can be reached. Use a wedge or mount on a narrow wall to increase the azimuth angle, up to $+45^{\circ}/-45^{\circ}$.

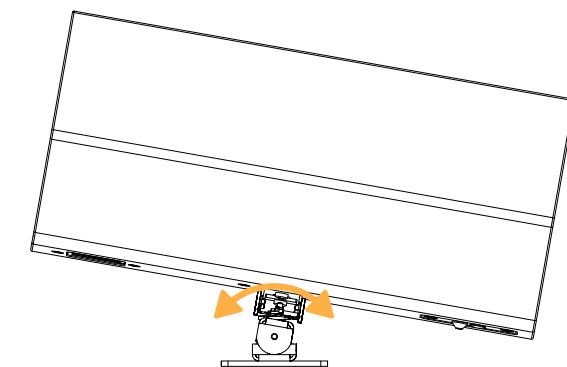

13. Tighten the M8×16 Torx screw. Apply a torque of 10 N.m.

Make sure the assembly is stable.

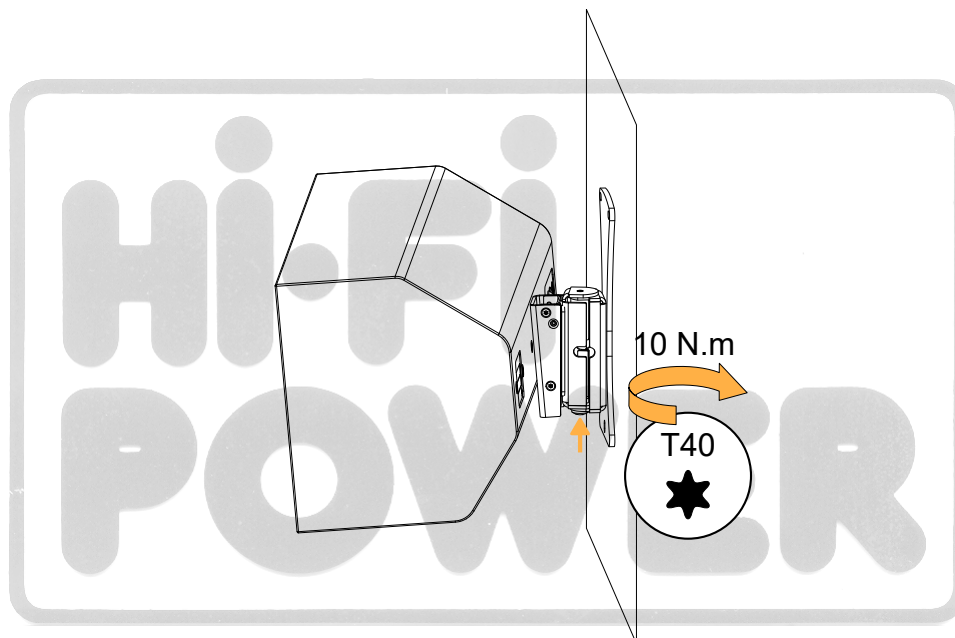

Wall-mounting X8i horizontally with PAN and TILT

Type of deployment	wall-mounting
Rigging accessories	TILT-SUPPORT
	PAN
	TILT
Additional material	3 compatible screws and anchors
Tools	torque screwdriver
	T20 Torx bit
	T30 Torx bit
	T40 Torx bit
	T20 screwdriver
	8 mm wrench or 8 mm hex socket
	10 mm wrench or 10 mm hex socket
Min. number of operators	1

Assembly overview

Pay attention to the position of the accessory parts throughout the procedure.

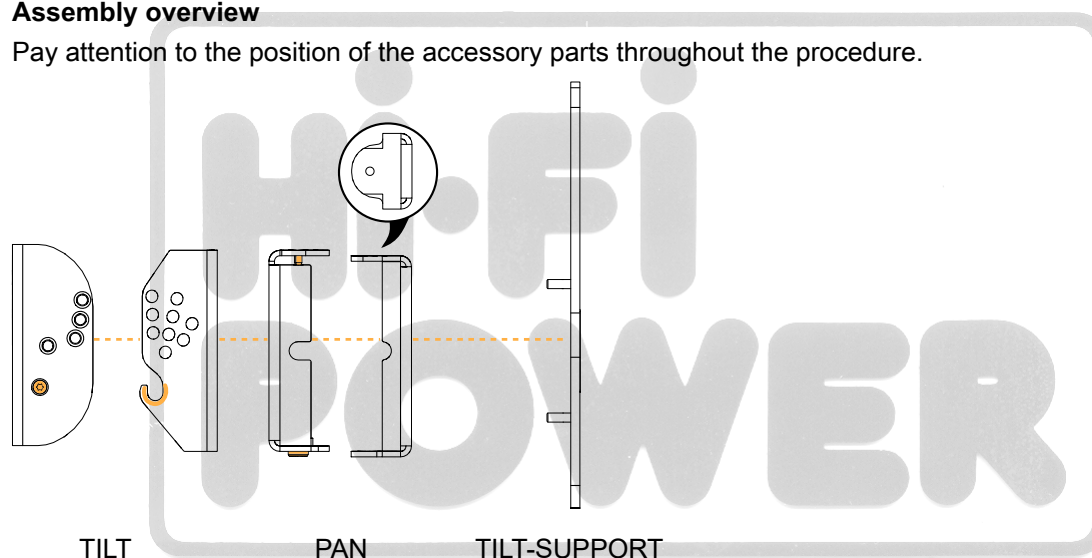

Secondary safety for flown, wall-mounted, or ceiling-mounted enclosures

Use one insert at the back of the enclosure to implement a secondary safety.

Risk of crushing injury

Ensure that the wall or ceiling can support the load of the product.

It is recommended to mount only on solid structures. If mounting on a hollow structure (such as a wall cavity), place anchoring points on the framework (wall studs, ceiling joists), or reinforce the mounting area.

Select screws and anchors applicable to the wall or ceiling properties and to the load of the product. Prevent screws from loosening over time, using for example thread locker or lock washers.

Specifications for screws and anchors

deployment	accessory	ultimate tensile load per screw (daN)	ultimate shear load per screw (daN)	screws quantity	mounting hole size	specific constraints
wall-mounting	TILT-SUPPORT + any accessory	12	9	3	Ø 6.4 mm / 0.25 in (slotted)	–



Risk of falling objects

Do not use PAN or PANx2 upside-down.

Do not swap the wall-mounting part(s) and the enclosure-mounting part(s).



Risk of falling objects

Do not use TILT, TILT5, TILT15, or TILT40 upside-down. These rigging accessories are designed for negative site angles only.

Screws and fasteners

from TILT-SUPPORT



x2



x2

M5 hex locknut

thick plain washer Ø
5 mm

from PAN

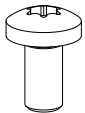

x2

M8x16 Torx



x2

M6x25 Torx



x2

M6 hex lock nut



x2

flat washer Ø 6 mm

from TILT

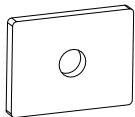

x1

rectangular washer

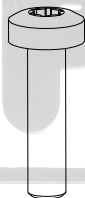

x2

M6x25 Torx



x1

M4x16 Torx
(pre-mounted)



x1

Axis with M4
Torx head (pre-
mounted)

Assembly

Prerequisite

Place X8i on its front face on a clean flat surface.

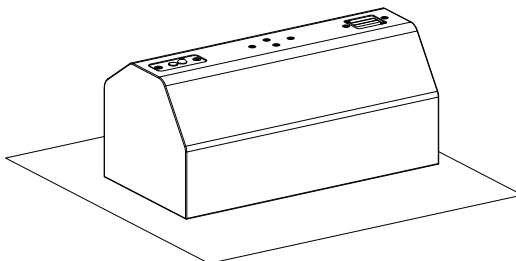

Procedure



Make sure to leave enough space between the walls and the sides of the rigging element to access the screw(s) when the enclosure is mounted.

1. Drill holes in the wall for TILT-SUPPORT.

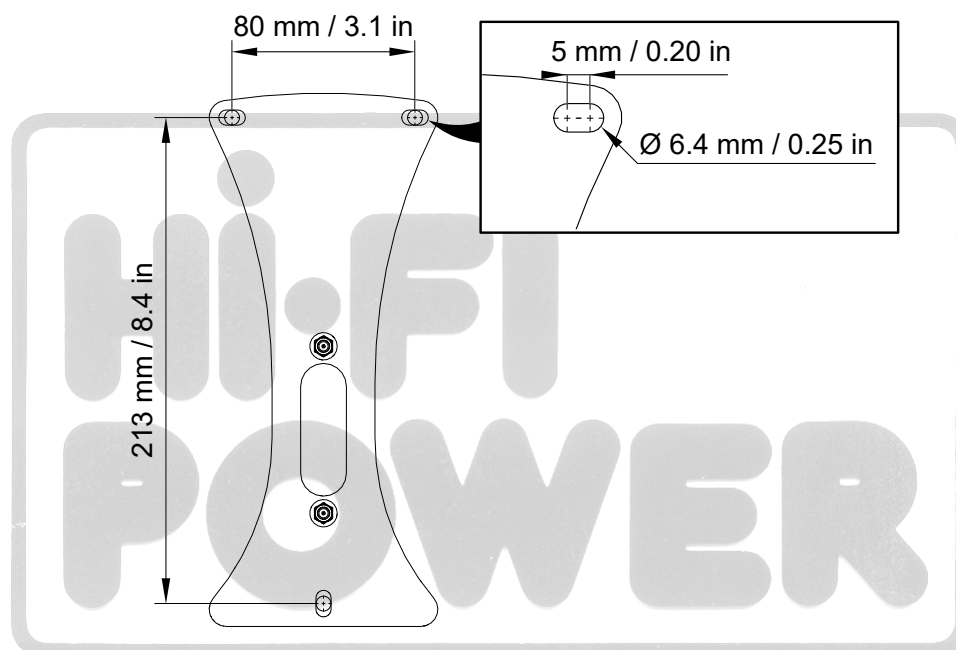

2. Assemble the PAN wall-mounting part with TILT-SUPPORT.

Use the two M5 nuts and washers.

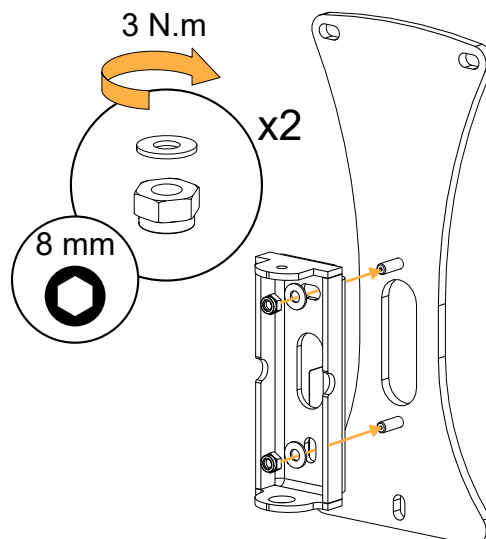

3. Secure TILT-SUPPORT and PAN to the wall.

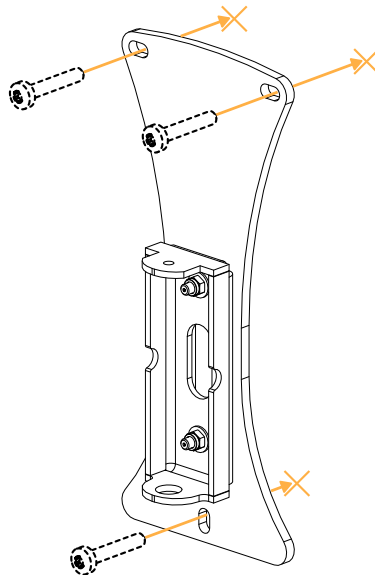

4. Disassemble the two TILT parts.

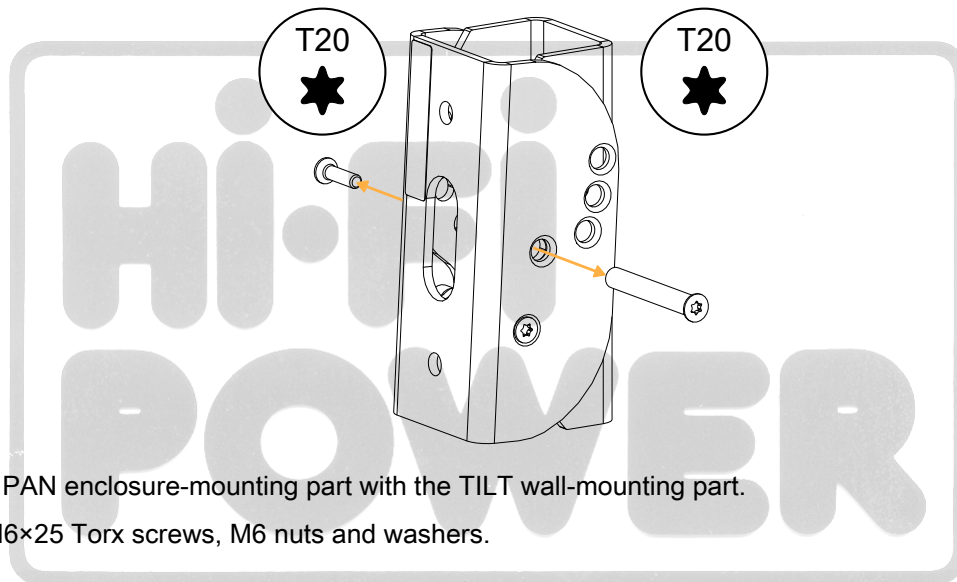

5. Assemble the PAN enclosure-mounting part with the TILT wall-mounting part. Use the two M6×25 Torx screws, M6 nuts and washers.

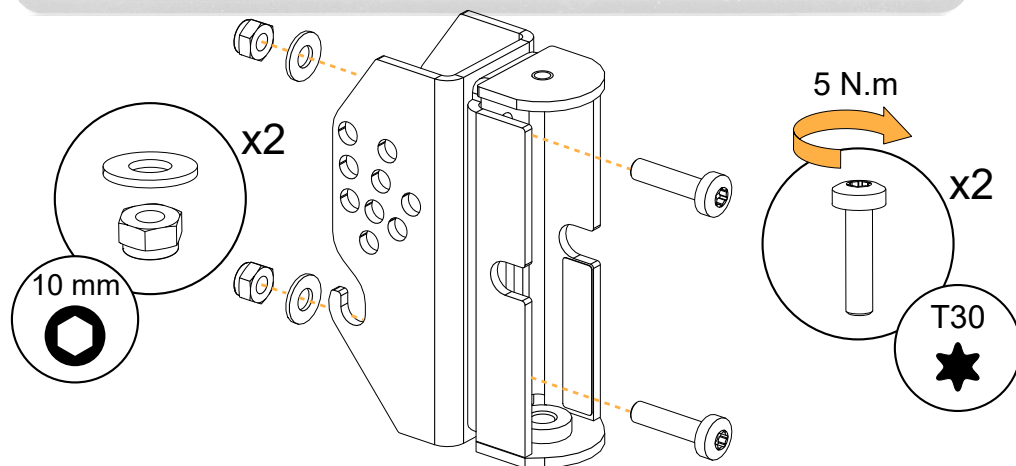

6. Mount the assembly on the PAN wall-mounting part:

- a) Align the pin with the top hole and push the assembly downwards.
- b) Drive the M8×16 Torx screw from underneath PAN.

! Do not fully tighten the screw.

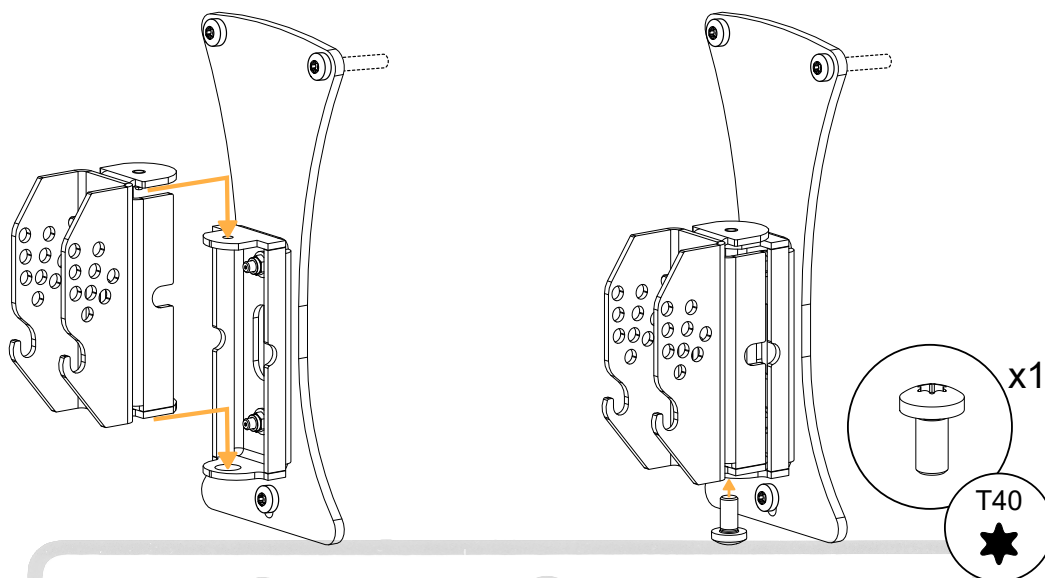

7. Secure TILT to X8i:

- a) Remove the two placeholder screws in the middle of X8i.
 - b) Secure the TILT enclosure-mounting part with the rectangular washer to X8i.
- Use the two M6×25 Torx screws.

! Align the top and the middle hole (formed by the washer) from the rigging accessory with the top and bottom hole on X8i, respectively.

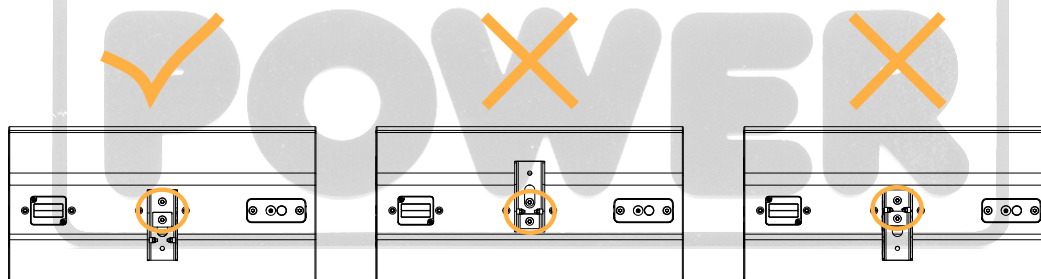

! Make sure the rectangular washer is in the correct position.

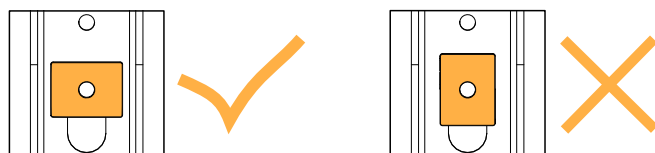

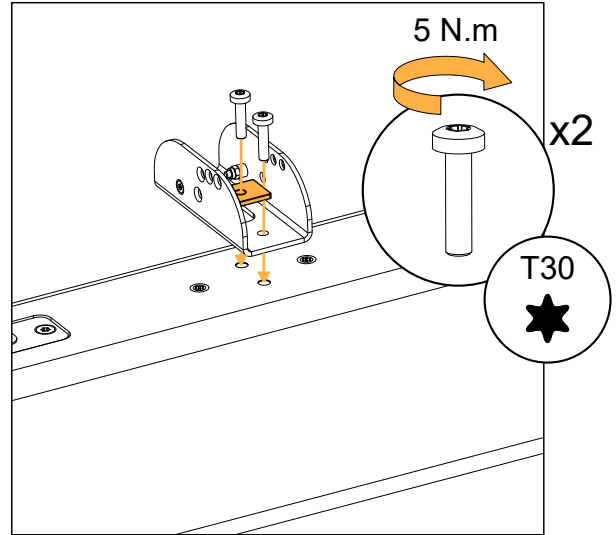
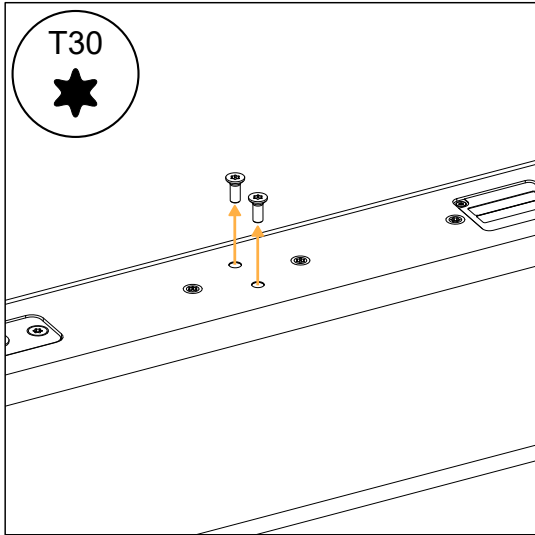

8. Prepare the cabling. Refer to [Cabling X8i](#) (p.171).
9. Mount X8i on the PAN and TILT assembly:
 - a) Assemble the two TILT parts by fitting the indexing studs into the hooks.
Make sure the studs are pushed all the way into the hooks.

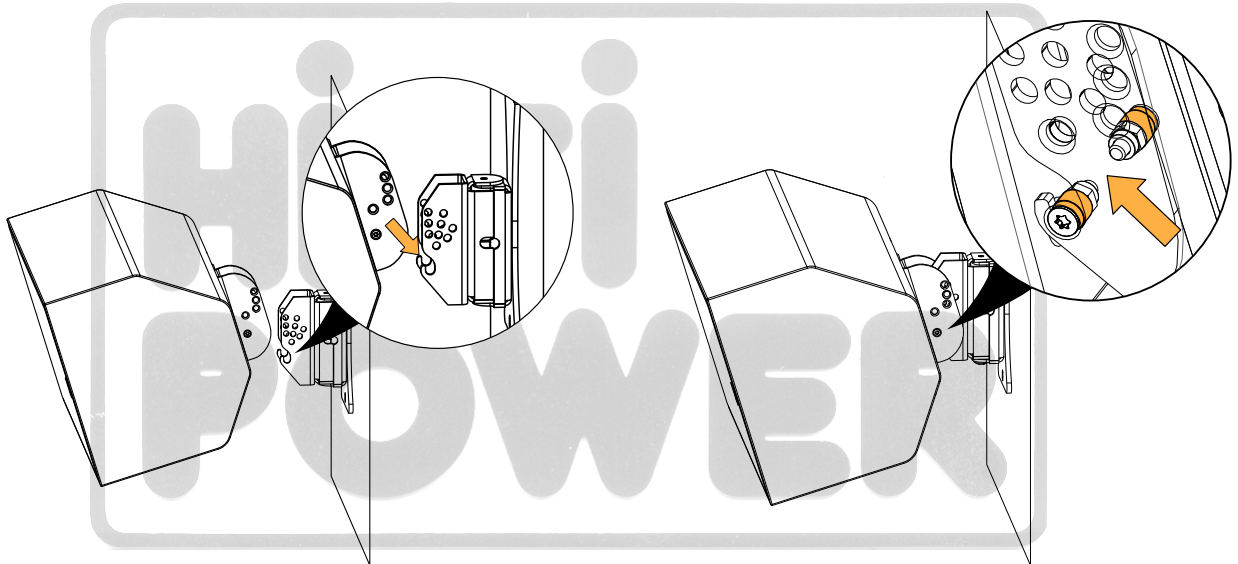

- b) Rotate the assembly to select the site angle.

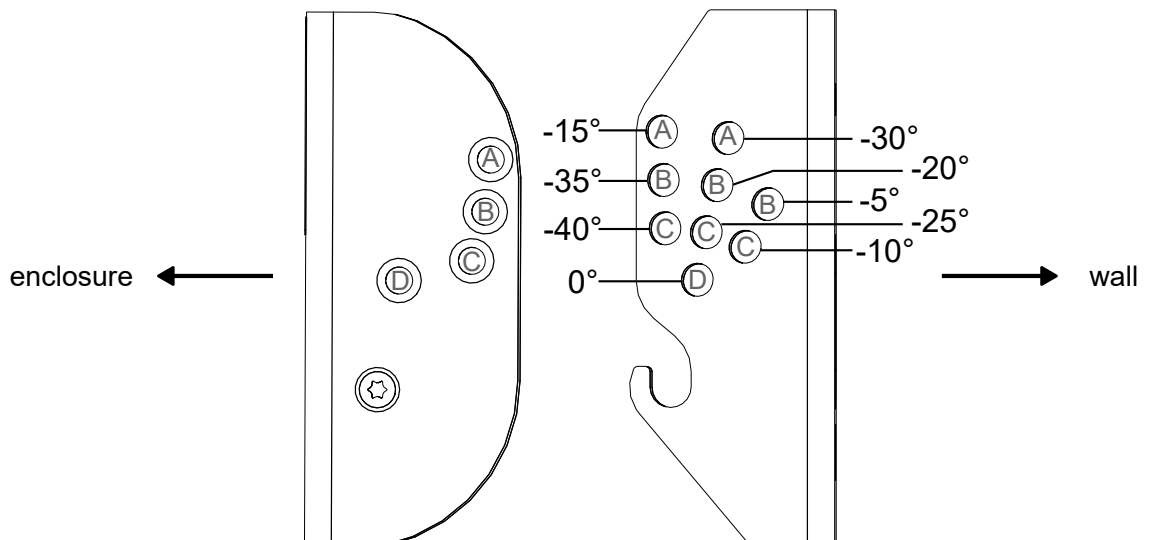

c) Drive the axis through the holes and secure it with the M4×16 Torx screw.

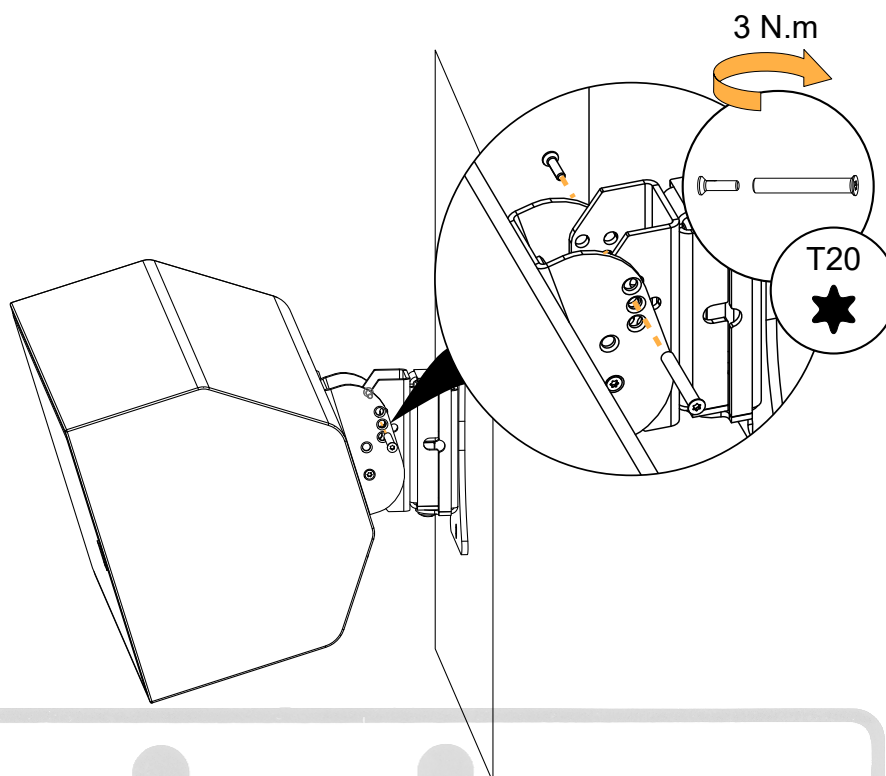

10. Rotate the assembly to adjust the azimuth angle.



Azimuth angle in horizontal orientation

When X8i is mounted horizontally with PAN against a wall, an azimuth angle of $+9^{\circ}/-9^{\circ}$ can be reached. Use a wedge or mount on a narrow wall to increase the azimuth angle, up to $+45^{\circ}/-45^{\circ}$.

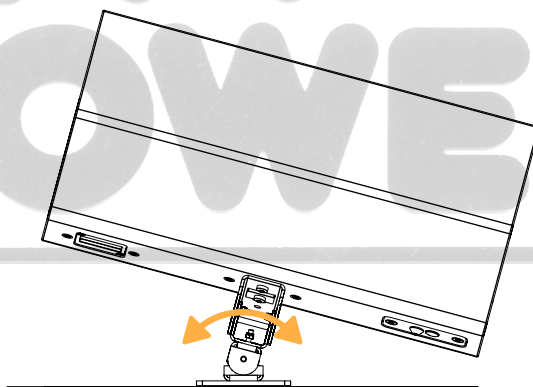

11. Tighten the M8×16 Torx screw. Apply a torque of 10 N.m.

Make sure the assembly is stable.

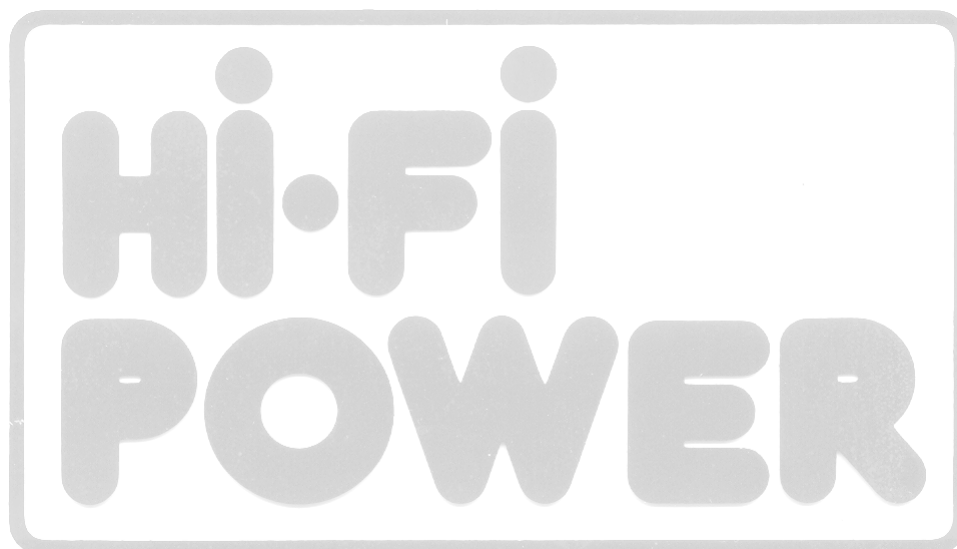
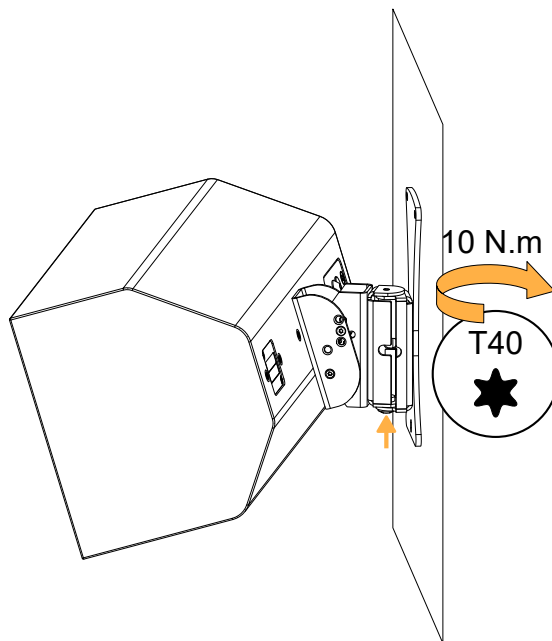

Ceiling-mounting or truss-mounting

Overview

X8i ceiling-mounted vertically

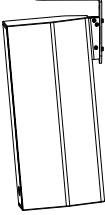
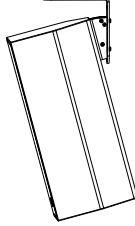
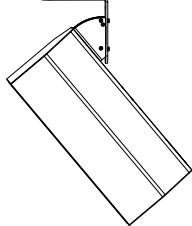
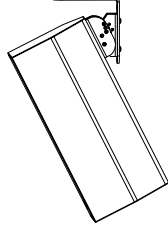
site angle				
0°	-5°	-15°	-40°	0° to -40°
VBAR (p.130) 	VBAR + TILT5 (p.137) 	VBAR + TILT15 (p.137) 	VBAR + TILT40 (p.137) 	VBAR + TILT (p.142) 

X8i ceiling-mounted horizontally

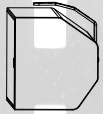
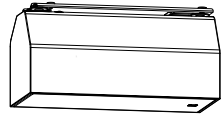
site angle	
0° to -35°	90° (downward-facing)
X8i-HBAR (p.147) 	X8i-onCW (p.155) 

X8i truss-mounted or suspended by a threaded rod

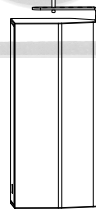
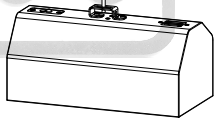
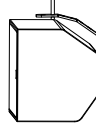
orientation	site angle	
	9° to -17°	90° (downward-facing)
Vertical	VBAR (p.130) 	CEILING-PENDANT (p.160) 
Horizontal	9° to -40° X8i-HBAR (p.147) 	

Vertically

Ceiling-mounting or flying X8i vertically with VBAR

Type of deployment	ceiling-mounting or truss-mounting
Rigging accessories	VBAR
Additional material	2 compatible screws and anchors, or
	1 max. Ø10 mm / 0.39 in truss clamp, or
	1 max. Ø10 mm / 0.39 in threaded rod, with corresponding nuts and washers
Tools	torque screwdriver
	T30 Torx bit
Min. number of operators	2

Secondary safety for flown, wall-mounted, or ceiling-mounted enclosures

Use one insert at the back of the enclosure to implement a secondary safety.

Risk of crushing injury

Ensure that the wall or ceiling can support the load of the product.

It is recommended to mount only on solid structures. If mounting on a hollow structure (such as a wall cavity), place anchoring points on the framework (wall studs, ceiling joists), or reinforce the mounting area.

Select screws and anchors applicable to the wall or ceiling properties and to the load of the product. Prevent screws from loosening over time, using for example thread locker or lock washers.

Specifications for screws and anchors

deployment	accessory	ultimate tensile load per screw (daN)	ultimate shear load per screw (daN)	screws quantity	mounting hole size	specific constraints
ceiling-mounting	VBAR + optional TILT or TILTxx	19	–	2	Ø 10.4 mm / 0.41 in	use the holes 1 and 7 (at both ends)

 SPCON cannot be used in this configuration.

Screws and fasteners

from VBAR

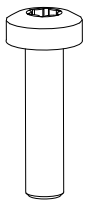

×2

M6×25 Torx

Ceiling-mounting X8i with VBAR

About this task

! For this configuration, the speaker cable must be run inside the ceiling.

Prerequisite

Place X8i on its front face on a clean flat surface.

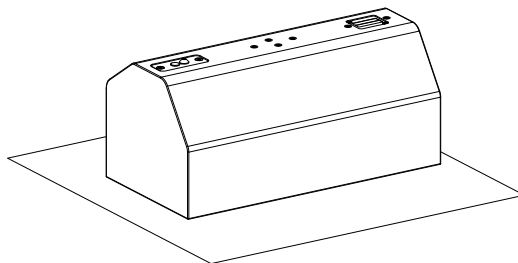

Procedure



Ceiling-mounting holes

When ceiling-mounting with VBAR, always use holes 1 and 7 (at both ends) to ensure optimal support.



Make sure to leave enough space between the walls, the sides, and the rear of the rigging element to access the screw(s) when the enclosure is mounted.

1. Drill holes in the ceiling for VBAR.

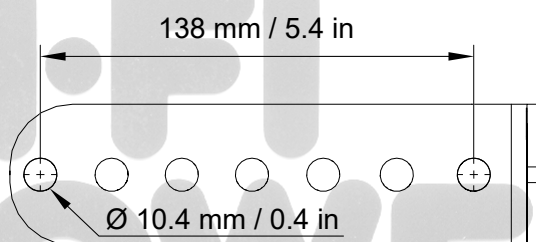

2. Secure VBAR to the ceiling.

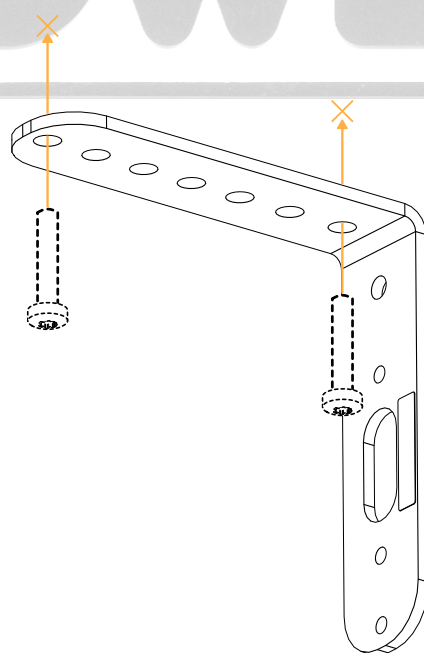

3. Run the speaker cable through VBAR.

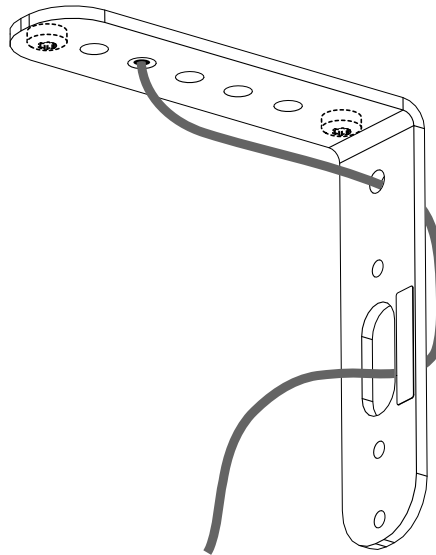

4. Prepare X8i cabling:

- a) Remove the connector sealing plate.
- b) Run the cable through the connector sealing plate.
- c) Connect the cable to the X8i terminal block. Refer to [Cabling X8i](#) (p.171).

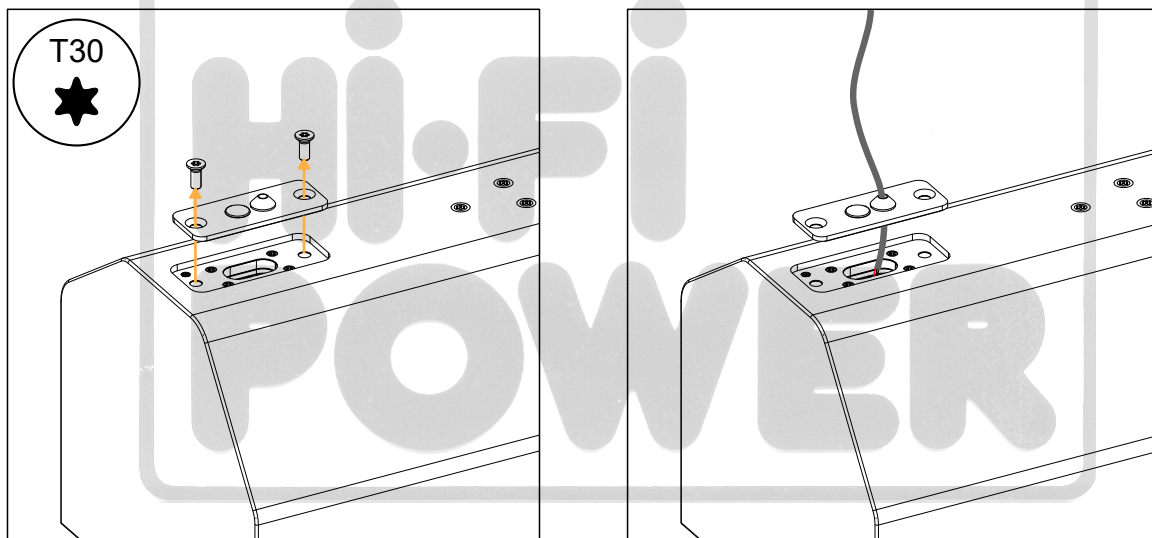

**Risk of crushing injury**

This step requires two operators.

5. Hold the connector sealing plate against the connector and secure X8i to VBAR.

Use two M6×25 Torx screws.

Make sure the assembly is stable.

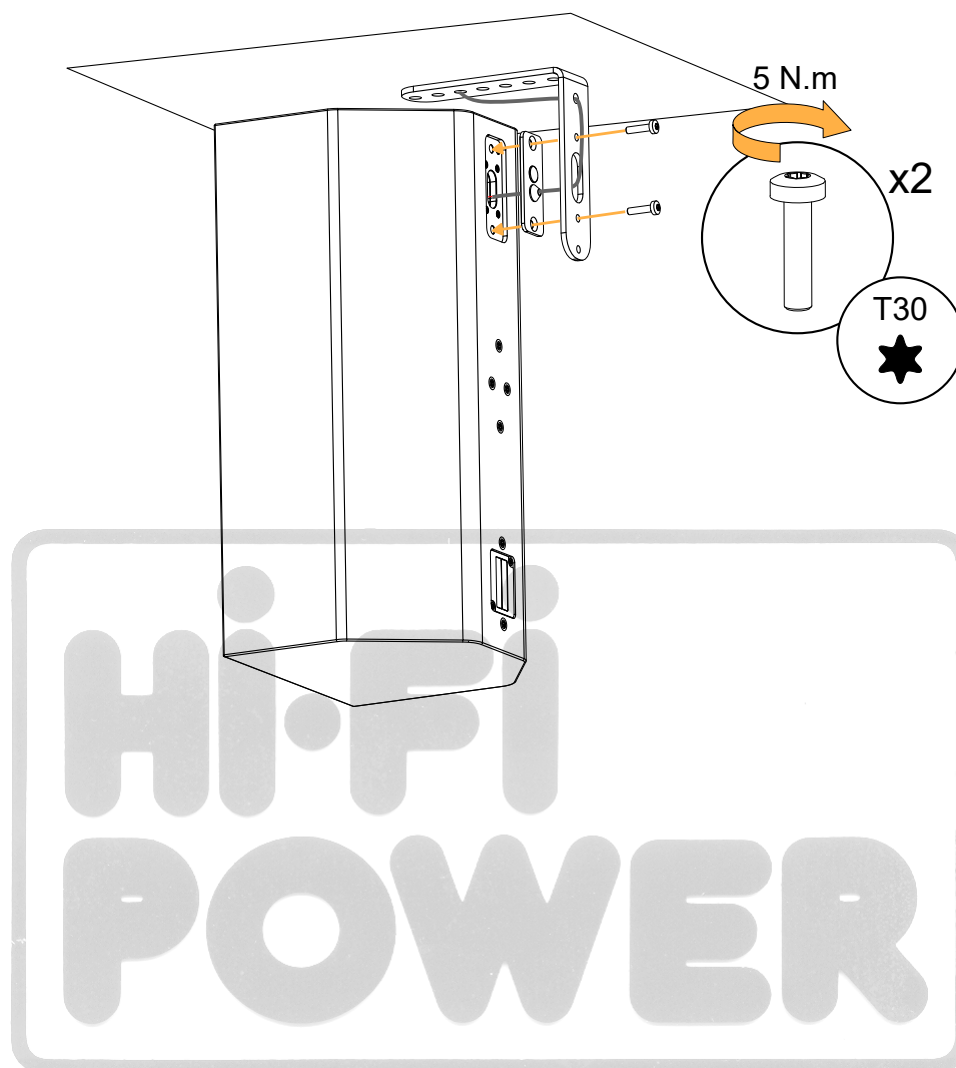

Flying X8i with VBAR

About this task

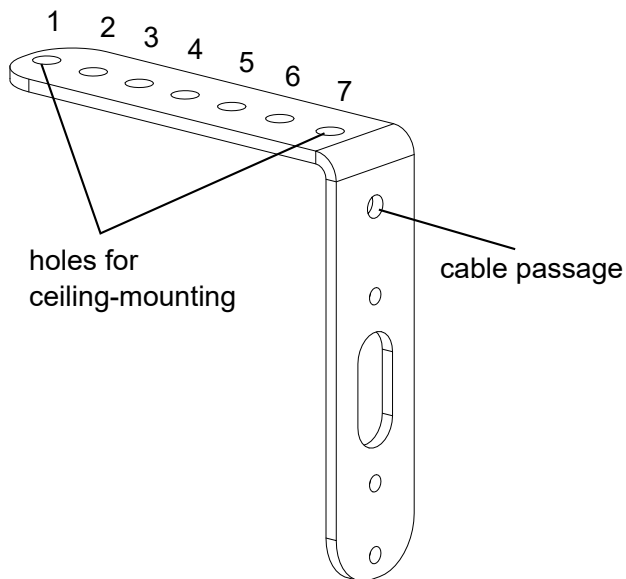

X8i site angles when flown or truss-mounted with VBAR

hole N°	angle
1	9°
2	5°
3	0°
4	-4°
5	-9°
6	-13°
7	-17°

Procedure

1. Run the speaker cable through VBAR.

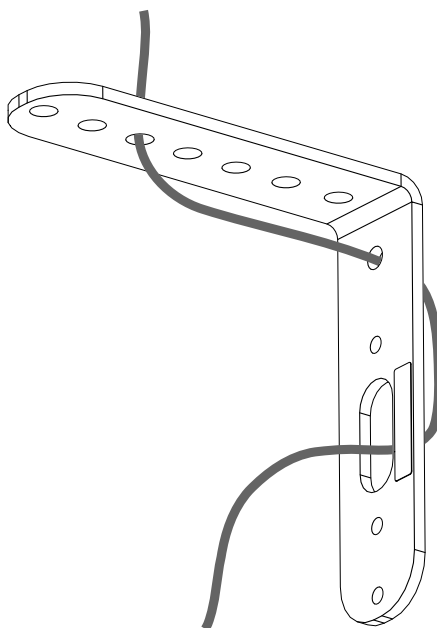

2. Prepare X8i cabling:

- a) Remove the connector sealing plate.
- b) Run the cable through the connector sealing plate.
- c) Connect the cable to the X8i terminal block. Refer to [Cabling X8i](#) (p.171).

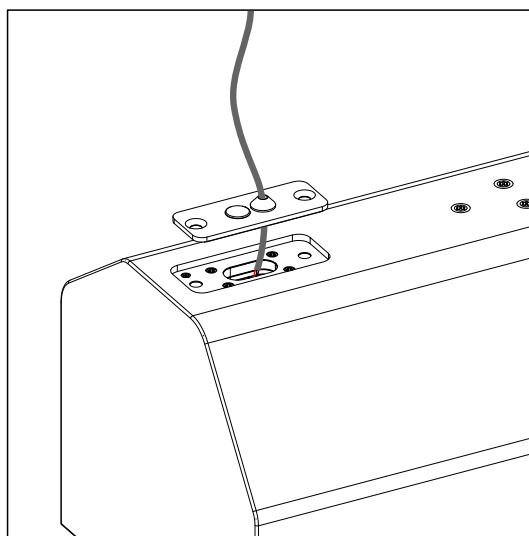
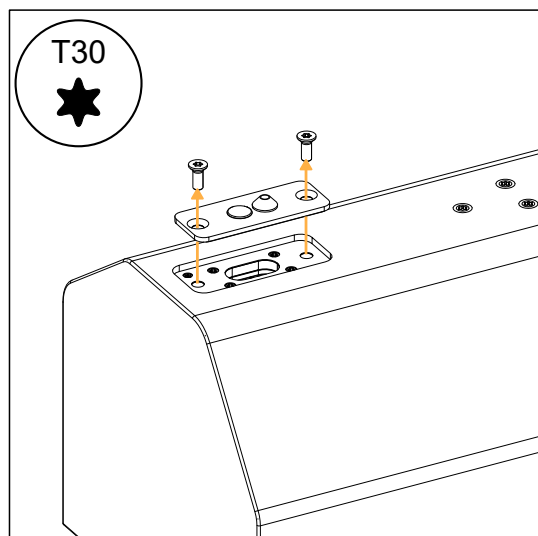

3. Hold the connector plate and position X8i upright.

4. Secure VBAR and the connector sealing plate to X8i.

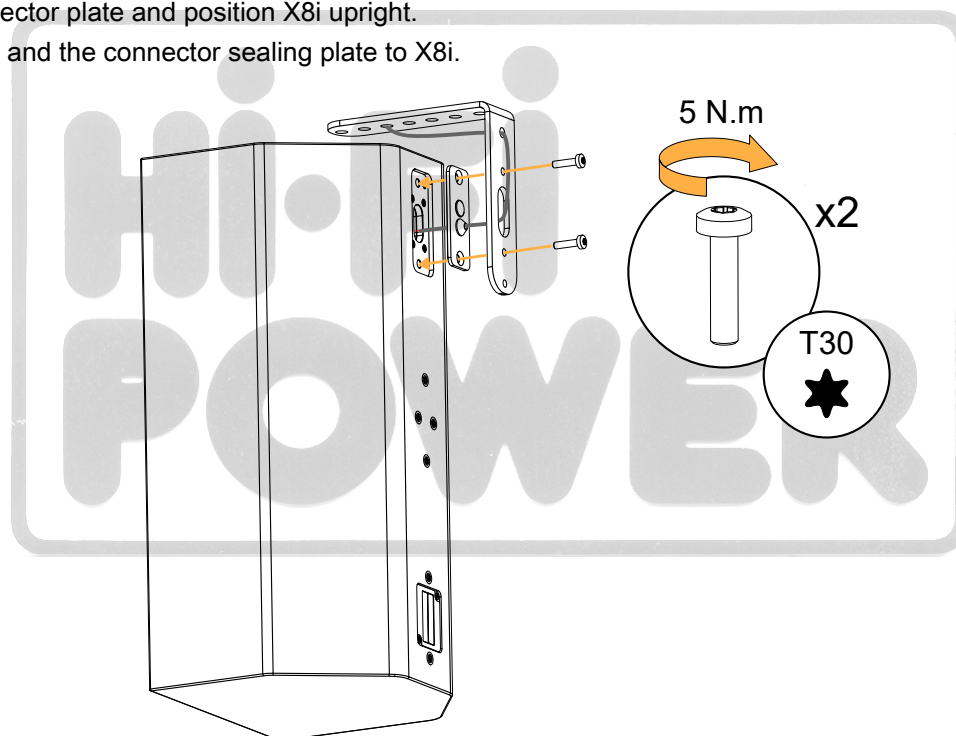



Risk of crushing injury

This step requires two operators.

5. Choose the pickup point and secure X8i to a truss clamp or a threaded rod (maximum $\varnothing 10$ mm / 0.39 in) using nuts.

Make sure the assembly is stable.

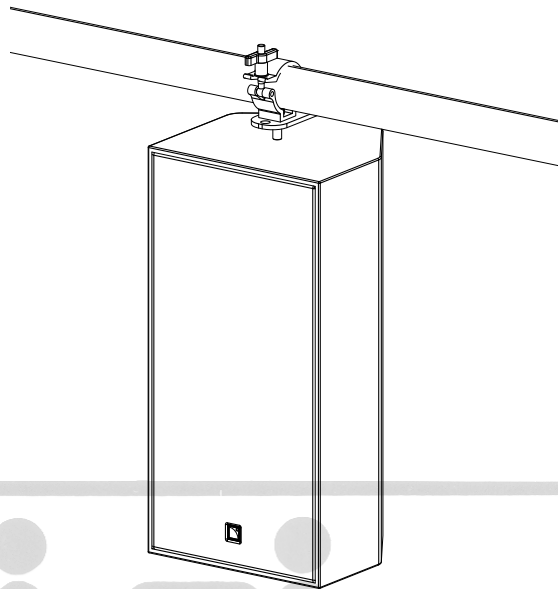

6. Fly X8i at desired height.

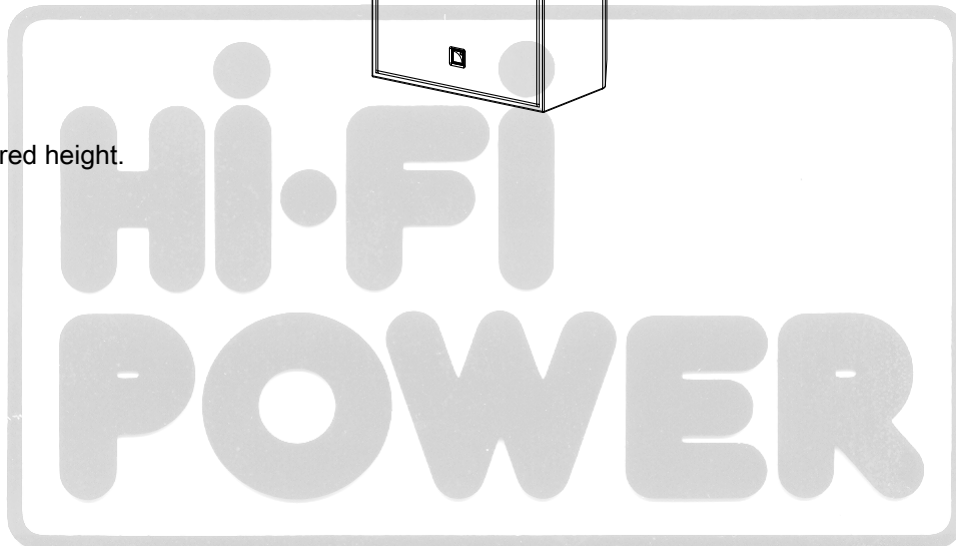

Ceiling-mounting X8i vertically with VBAR and TILT5/TILT15/TILT40

Type of deployment	ceiling-mounting
Rigging accessories	VBAR
	TILT5/TILT15/TILT40
Additional material	2 compatible screws and anchors
Tools	torque screwdriver
	T20 Torx bit
	T25 Torx bit
	T30 Torx bit
	8 mm wrench or 8 mm hex socket
Min. number of operators	2

Assembly overview

Pay attention to the position of the accessory parts throughout the procedure.

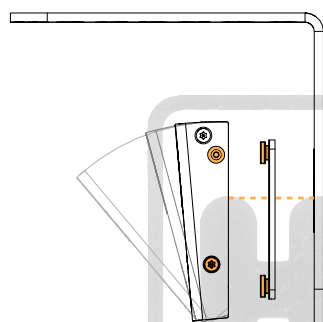

TILTxx VBAR

Secondary safety for flown, wall-mounted, or ceiling-mounted enclosures

Use one insert at the back of the enclosure to implement a secondary safety.

Risk of crushing injury

Ensure that the wall or ceiling can support the load of the product.

It is recommended to mount only on solid structures. If mounting on a hollow structure (such as a wall cavity), place anchoring points on the framework (wall studs, ceiling joists), or reinforce the mounting area.

Select screws and anchors applicable to the wall or ceiling properties and to the load of the product. Prevent screws from loosening over time, using for example thread locker or lock washers.

Specifications for screws and anchors

deployment	accessory	ultimate tensile load per screw (daN)	ultimate shear load per screw (daN)	screws quantity	mounting hole size	specific constraints
ceiling-mounting	VBAR + optional TILT or TILTxx	19	–	2	Ø 10.4 mm / 0.41 in	use the holes 1 and 7 (at both ends)

Risk of falling objects

Do not use TILT, TILT5, TILT15, or TILT40 upside-down. These rigging accessories are designed for negative site angles only.

Ceiling-mounting holes

When ceiling-mounting with VBAR, always use holes 1 and 7 (at both ends) to ensure optimal support.

Screws and fasteners

from VBAR



from TILT5/TILT15/TILT40

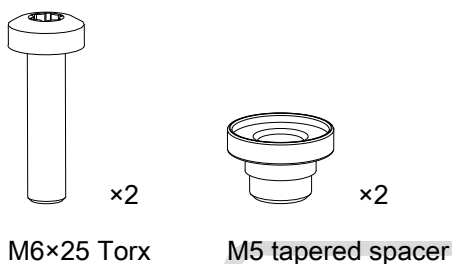

Assembly

About this task

i In this procedure, TILTxx designates the fixed angle accessories TILT5, TILT15, and TILT40.

Prerequisite

Place X8i on its front face on a clean flat surface.

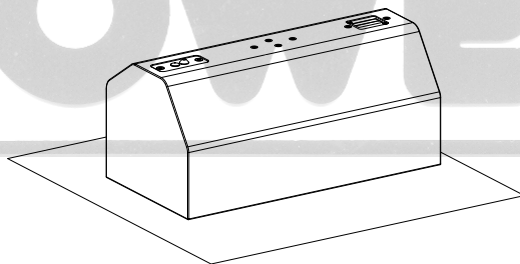

Make sure that the TILTxx safety screw is present and loosened.

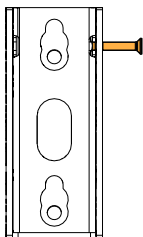

Procedure



Ceiling-mounting holes

When ceiling-mounting with VBAR, always use holes 1 and 7 (at both ends) to ensure optimal support.



Make sure to leave enough space between the walls, the sides, and the rear of the rigging element to access the screw(s) when the enclosure is mounted.

1. Drill holes in the ceiling for VBAR.

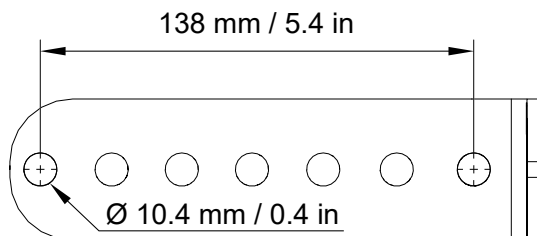

2. Secure VBAR to the ceiling.

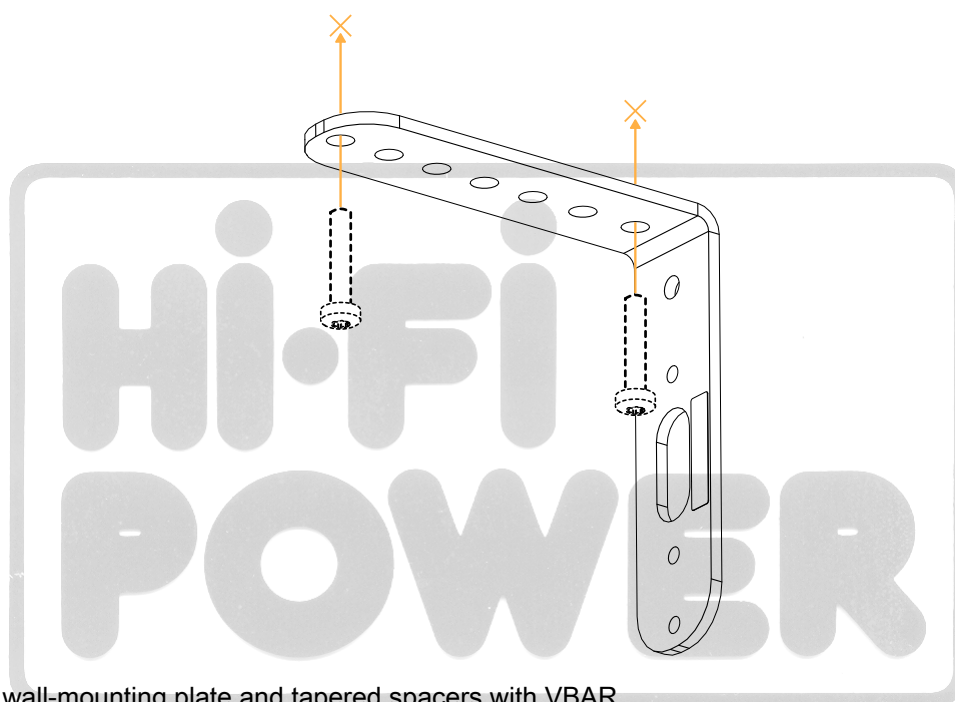

3. Assemble the wall-mounting plate and tapered spacers with VBAR.

Use two M5×20 Torx, two M5 washers, and two M5 nuts.

The wall-mounting plate gasket is facing away from VBAR.

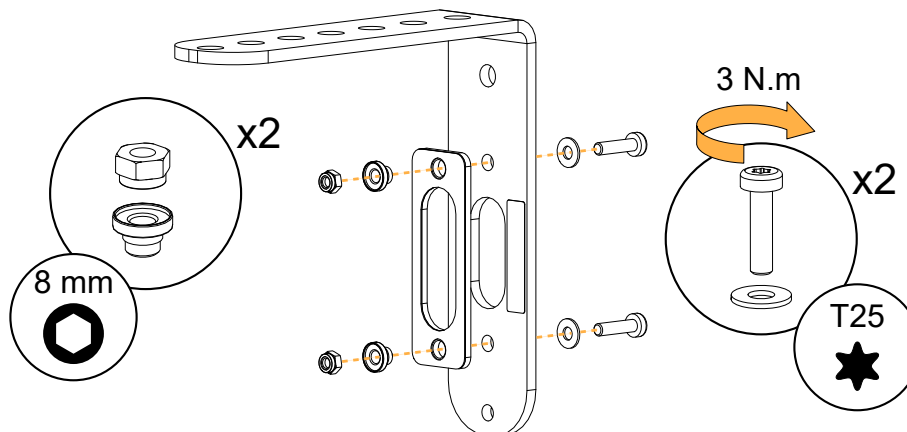

4. Run the speaker cable through VBAR.

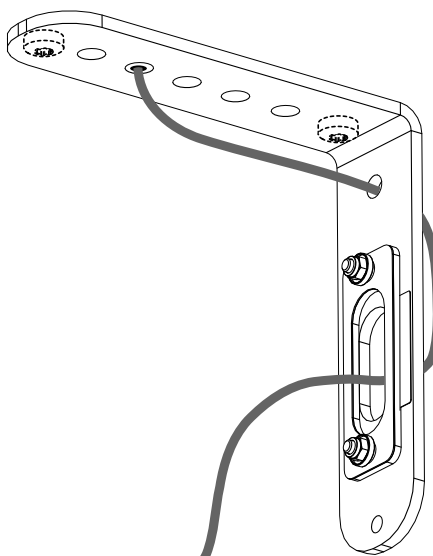

5. Secure TILTxx to X8i:

- a) Remove the connector sealing plate (if present) or the placeholder screws.
- b) Run the cable through TILTxx and through the connector sealing plate.
- c) Connect the speaker cable to the X8i terminal block. Refer to [Cabling X8i](#) (p.171).
- d) Secure TILTxx and the connector sealing plate to X8i.

Use two M6×25 Torx screws.

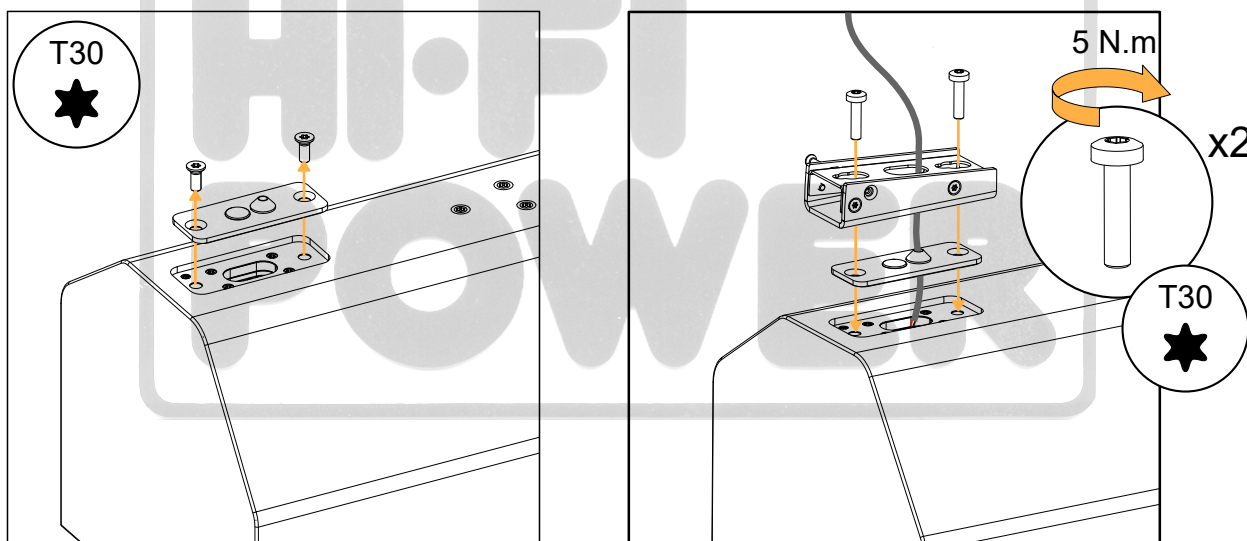



Risk of crushing injury

This step requires two operators.

6. Mount X8i on VBAR:

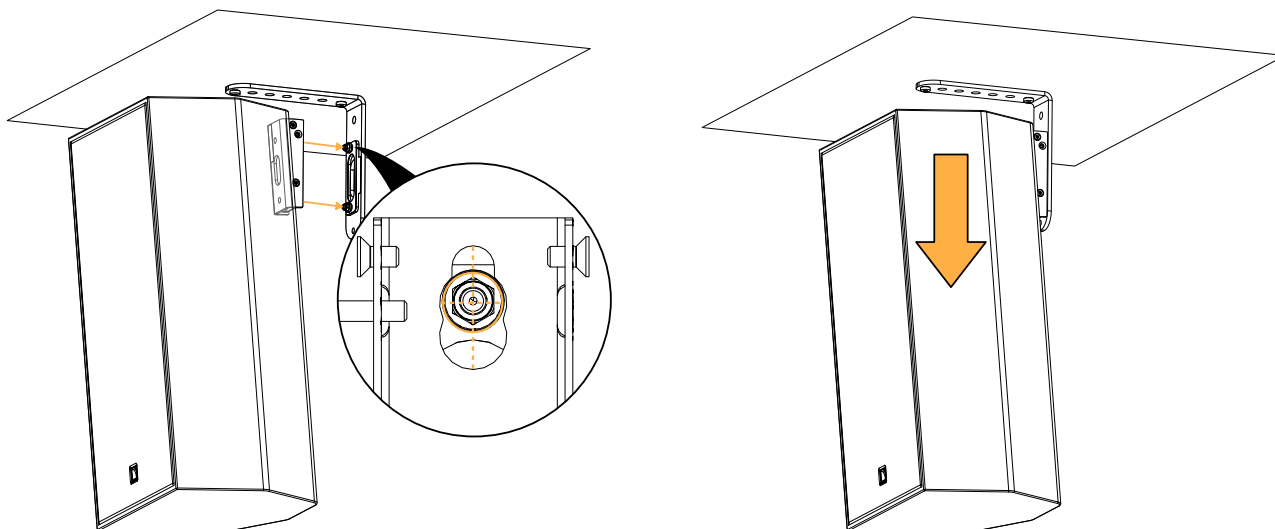
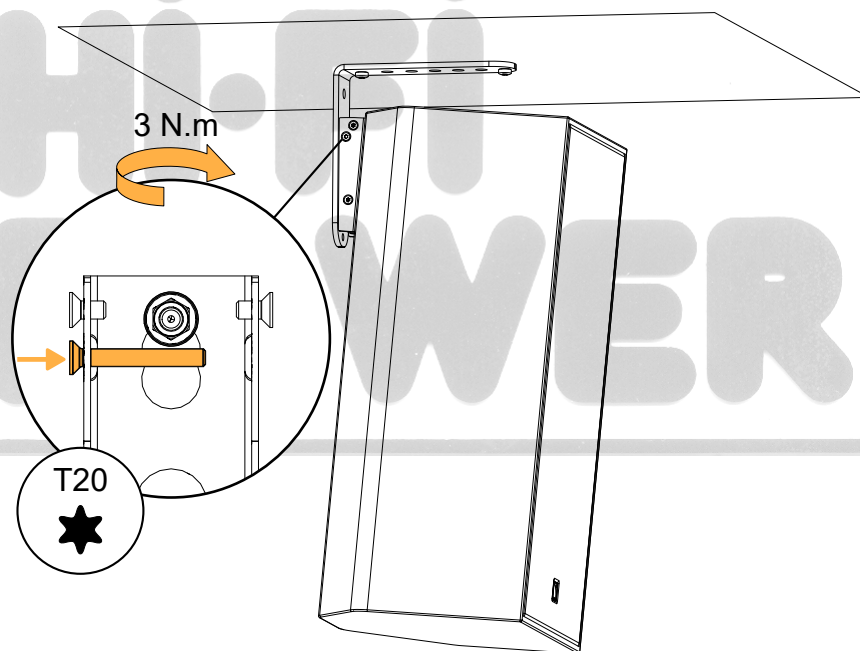
- a) Align the midpoints of the TILTxx rear cutouts with the tapered spacers.
- b) Push the assembly downwards.



7. Tighten the safety screw and make sure the assembly is stable.

Ceiling-mounting X8i vertically with VBAR and TILT

Type of deployment	ceiling-mounting
Rigging accessories	VBAR
	TILT
Additional material	2 compatible screws and anchors
Tools	torque screwdriver
	T20 Torx bit
	T30 Torx bit
	T40 Torx bit
	T20 screwdriver
	10 mm wrench or 10 mm hex socket
Min. number of operators	2

! Assembly overview

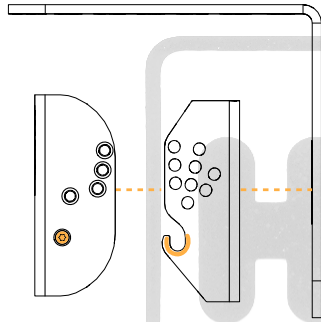
Pay attention to the position of the accessory parts throughout the procedure.



TILT VBAR

! Secondary safety for flown, wall-mounted, or ceiling-mounted enclosures

Use one insert at the back of the enclosure to implement a secondary safety.

! Risk of crushing injury

Ensure that the wall or ceiling can support the load of the product.

It is recommended to mount only on solid structures. If mounting on a hollow structure (such as a wall cavity), place anchoring points on the framework (wall studs, ceiling joists), or reinforce the mounting area.

Select screws and anchors applicable to the wall or ceiling properties and to the load of the product. Prevent screws from loosening over time, using for example thread locker or lock washers.

Specifications for screws and anchors

deployment	accessory	ultimate tensile load per screw (daN)	ultimate shear load per screw (daN)	screws quantity	mounting hole size	specific constraints
ceiling-mounting	VBAR + optional TILT or TILTxx	19	–	2	Ø 10.4 mm / 0.41 in	use the holes 1 and 7 (at both ends)

! Risk of falling objects

Do not use TILT, TILT5, TILT15, or TILT40 upside-down. These rigging accessories are designed for negative site angles only.

Screws and fasteners

from VBAR

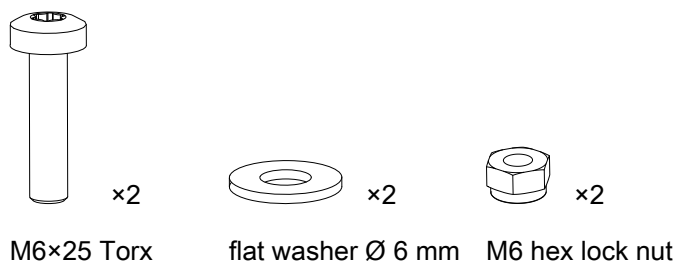

from TILT

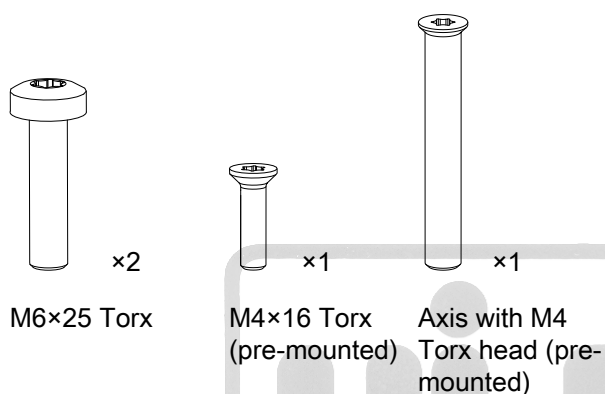

Assembly

About this task



In this procedure, TILTxx designates the fixed angle accessories TILT5, TILT15, and TILT40.

Prerequisite

Place X8i on its front face on a clean flat surface.

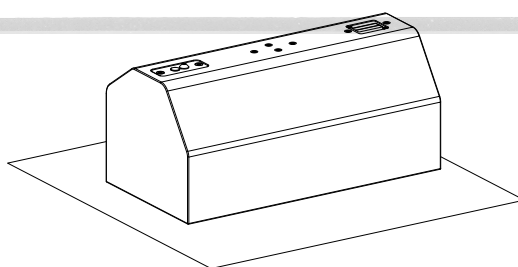

Procedure



Ceiling-mounting holes

When ceiling-mounting with VBAR, always use holes 1 and 7 (at both ends) to ensure optimal support.



Make sure to leave enough space between the walls, the sides, and the rear of the rigging element to access the screw(s) when the enclosure is mounted.

1. Drill holes in the ceiling for VBAR.

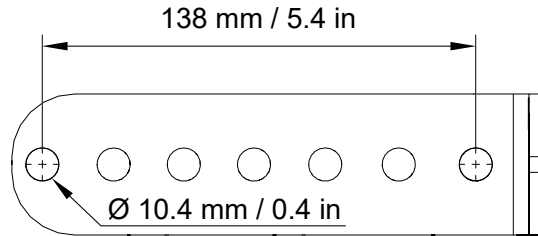

2. Assemble the TILT wall-mounting part with VBAR.

Use two M6×25 Torx, two M6 nuts and two M6 washers.

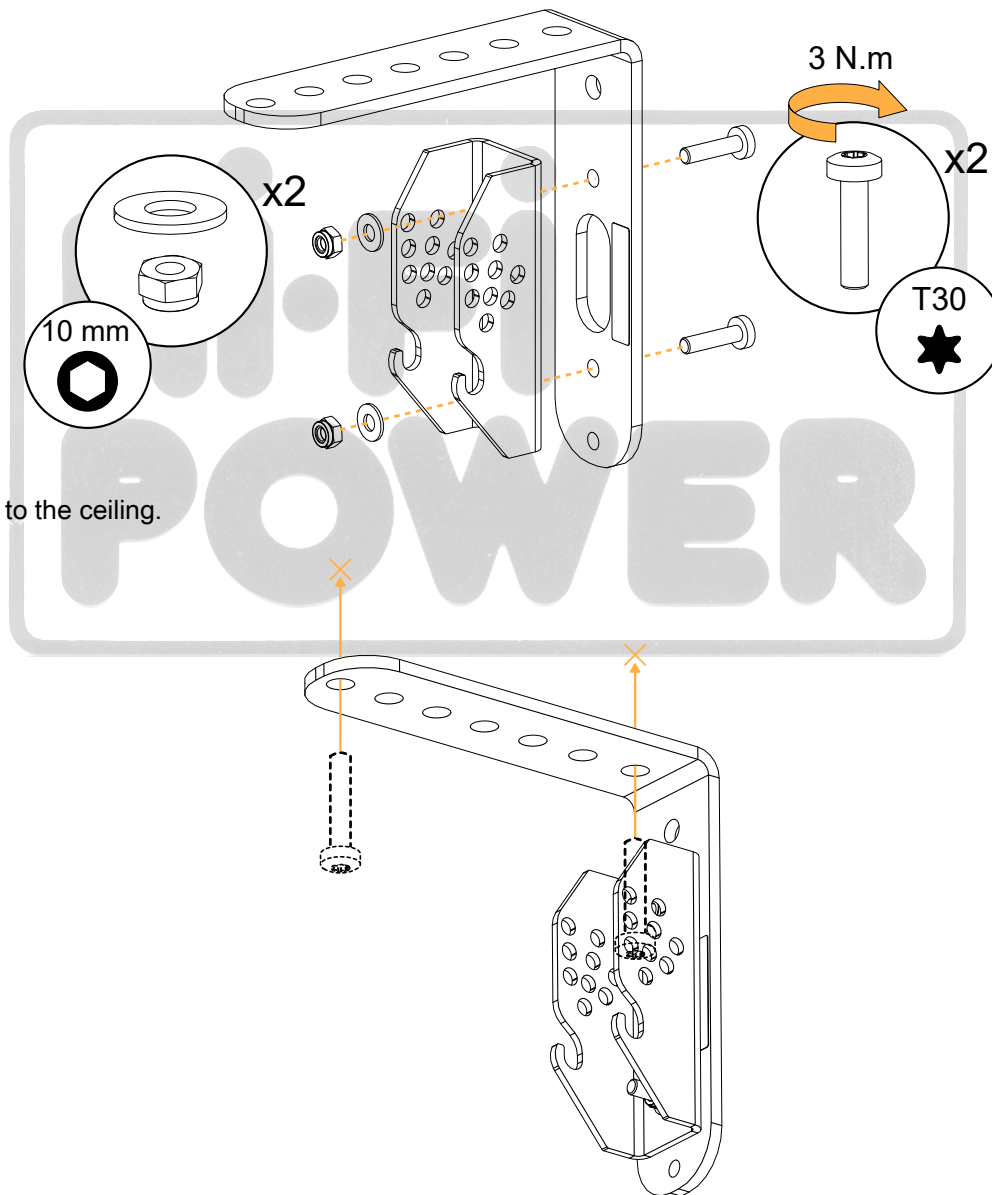

3. Secure VBAR to the ceiling.

4. Secure TILT to X8i:

- Remove the connector sealing plate (if present) or the placeholder screws.
- Run the cable through TILT and through the connector sealing plate.
- Connect the speaker cable to the X8i terminal block. Refer to [Cabling X8i](#) (p.171).
- Secure the TILT enclosure-mounting part and the connector sealing plate to X8i.

Use the two M6×25 Torx screws.

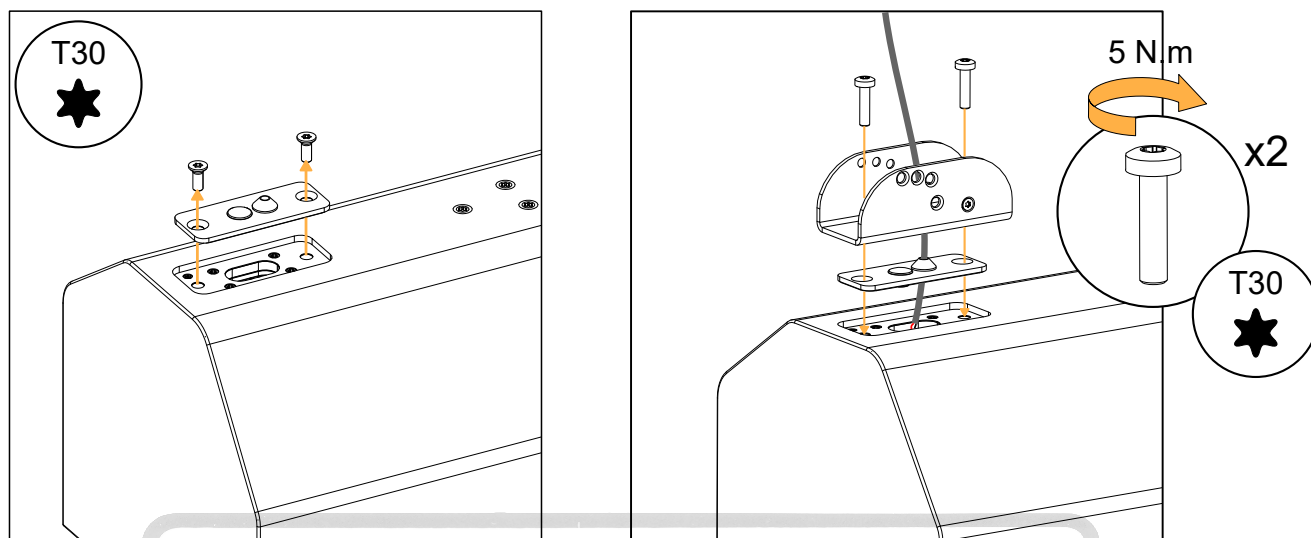

Risk of crushing injury

This step requires two operators.

5. Mount X8i on VBAR.

- Assemble the two TILT parts by fitting the indexing studs into the hooks.

Make sure that the studs are pushed all the way into the hooks.

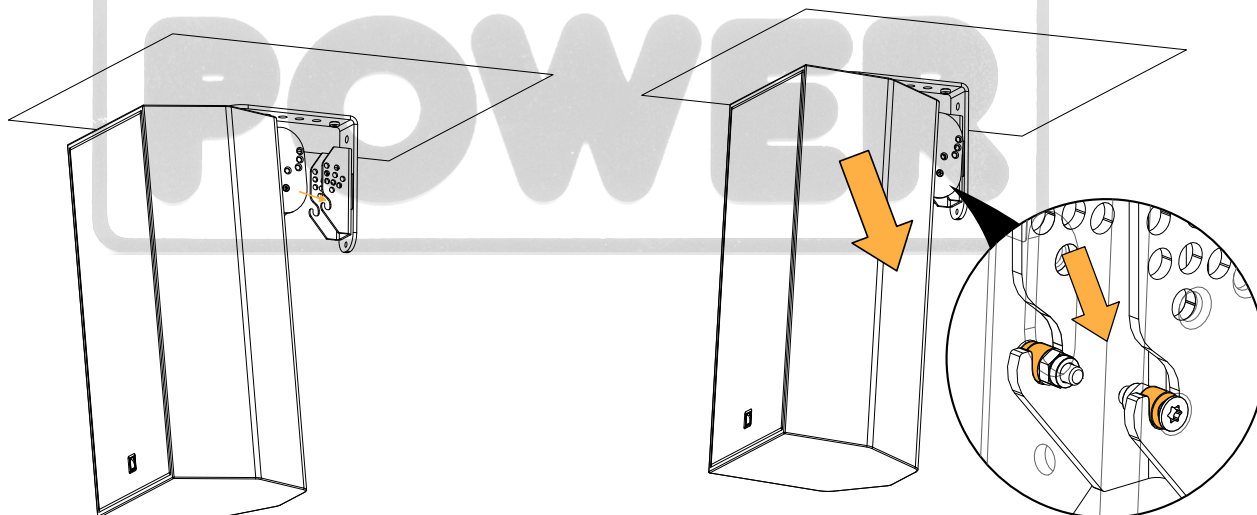

b) Rotate the assembly to select the site angle.

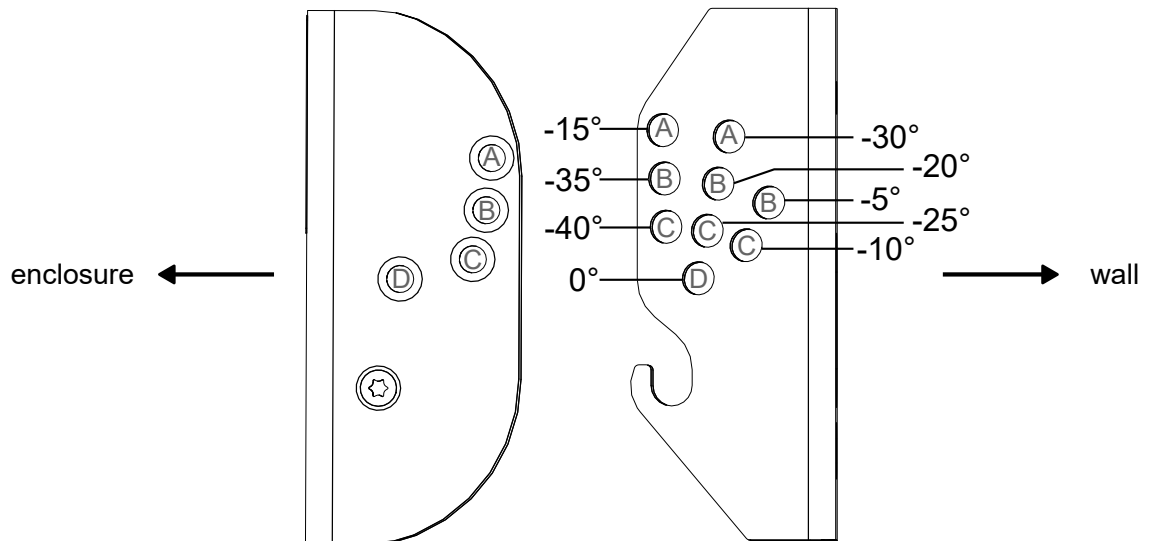

c) Drive the axis through the holes and secure it with the M4×16 Torx screw.

Make sure that the assembly is stable.

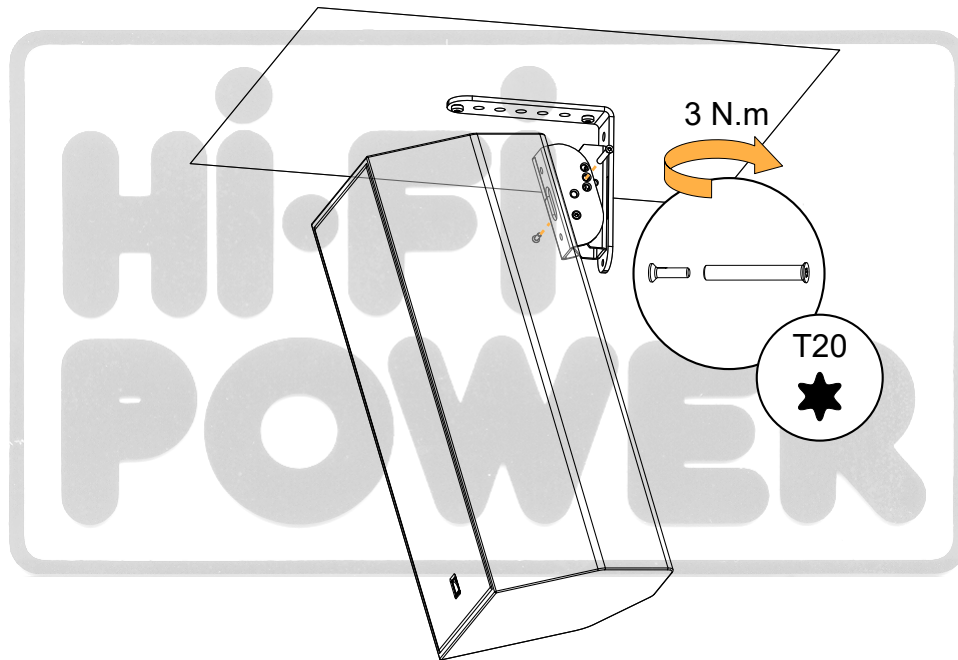

Horizontally

Ceiling-mounting or truss-mounting X8i horizontally with X8i-HBAR

Type of deployment	ceiling-mounting or truss-mounting
Rigging accessories	X8i-HBAR
Additional material	2 compatible screws and anchors, or
	1 max. Ø10 mm / 0.39 in truss clamp, or
	1 max. Ø10 mm / 0.39 in threaded rod, with corresponding nuts and washers
Tools	torque screwdriver
	T30 Torx bit
	level
Min. number of operators	2

! Secondary safety
Use available holes on the rigging accessories to implement a secondary safety.

! Risk of crushing injury
Ensure that the wall or ceiling can support the load of the product.
It is recommended to mount only on solid structures. If mounting on a hollow structure (such as a wall cavity), place anchoring points on the framework (wall studs, ceiling joists), or reinforce the mounting area.
Select screws and anchors applicable to the wall or ceiling properties and to the load of the product. Prevent screws from loosening over time, using for example thread locker or lock washers.

Specifications for screws and anchors

deployment	accessory	ultimate tensile load per screw (daN)	ultimate shear load per screw (daN)	screws quantity	mounting hole size	specific constraints
ceiling-mounting	X8i-HBAR	19	–	2	Ø 10.3 mm / 0.40 in	use two adjacent, coplanar holes distance between centers: 25 mm / 0.98 in

Screws and fasteners

from X8i-HBAR

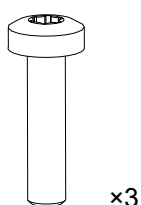

M6×25 Torx

Ceiling-mounting X8i horizontally with X8i-HBAR**About this task**

For this configuration, the speaker cable must be run inside the ceiling.

X8i site angles when ceiling-mounted with X8i-HBAR

holes N°	angle
1 + 2	0°
3 + 4	-14°
5 + 6	-35°

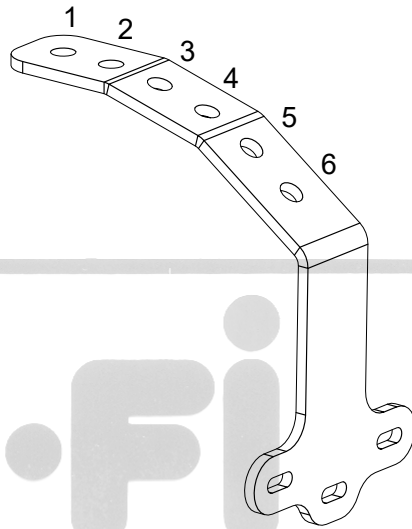
**Prerequisite**

Place X8i on its front face on a clean flat surface.

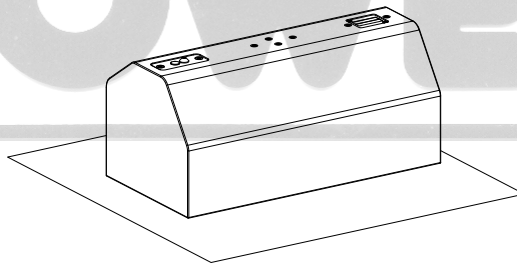

Procedure



Ceiling-mounting holes

When ceiling-mounting with X8i-HBAR, use one pair of adjacent, coplanar holes depending on the chosen site angle.

1. Drill holes in the ceiling for X8i-HBAR.

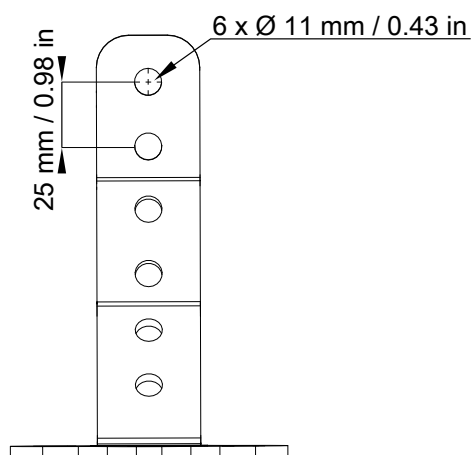

2. Secure X8i-HBAR to the ceiling.

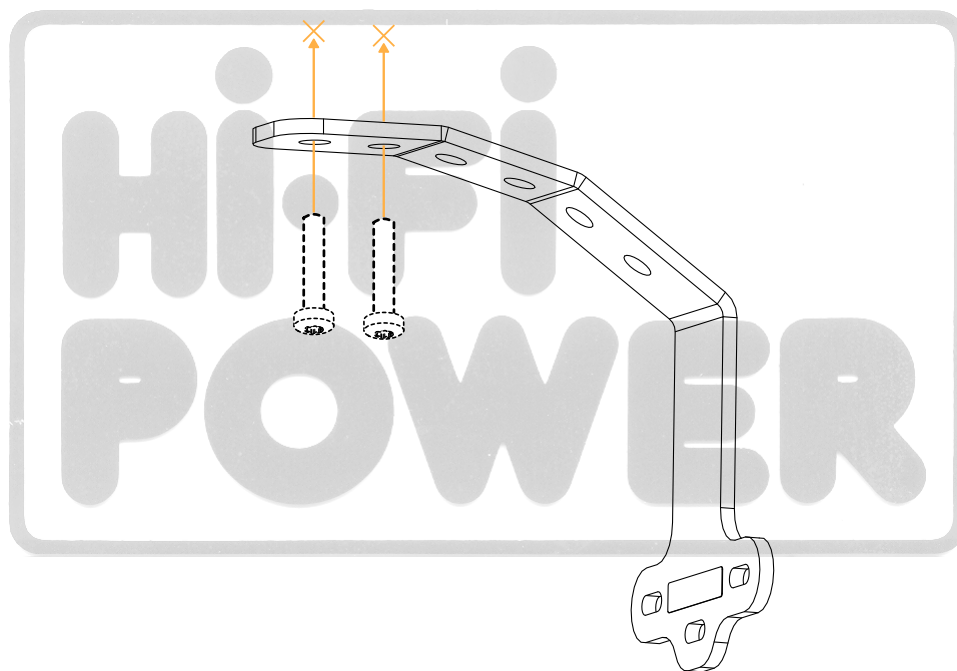

3. Remove the three placeholder screws in the middle of X8i.



X8i-HBAR can be mounted on a horizontal X8i turned either way:

- with the connector plate on the right-hand side
- with the connector plate on the left-hand side

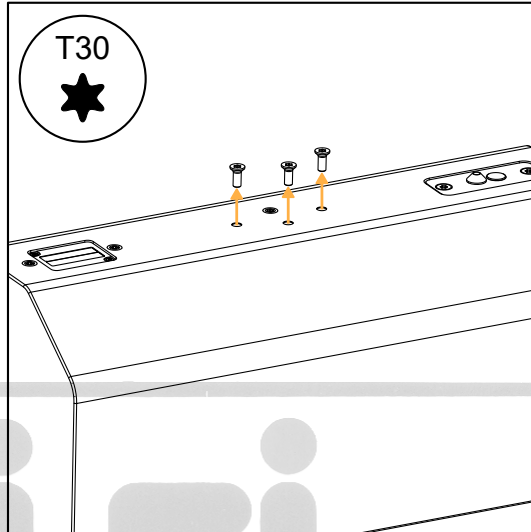
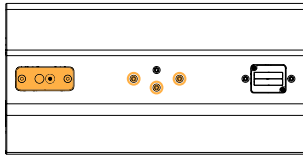
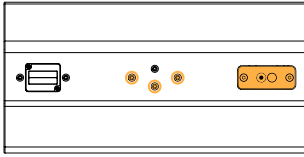

Risk of crushing injury

This step requires two operators.



Do not fully tighten the screws.

4. Mount X8i on X8i-HBAR.

Use three M6×25 Torx screws.

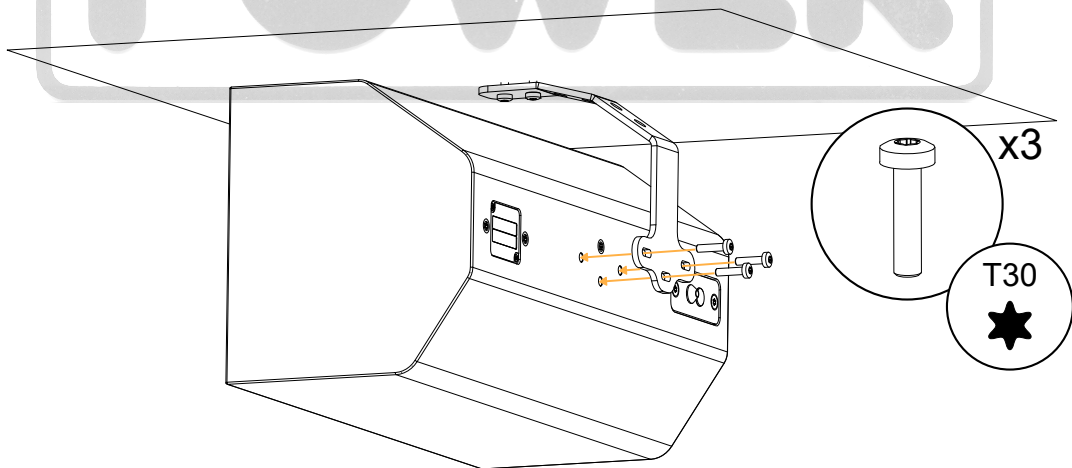

5. Tighten the screws.

Make sure the assembly is stable.

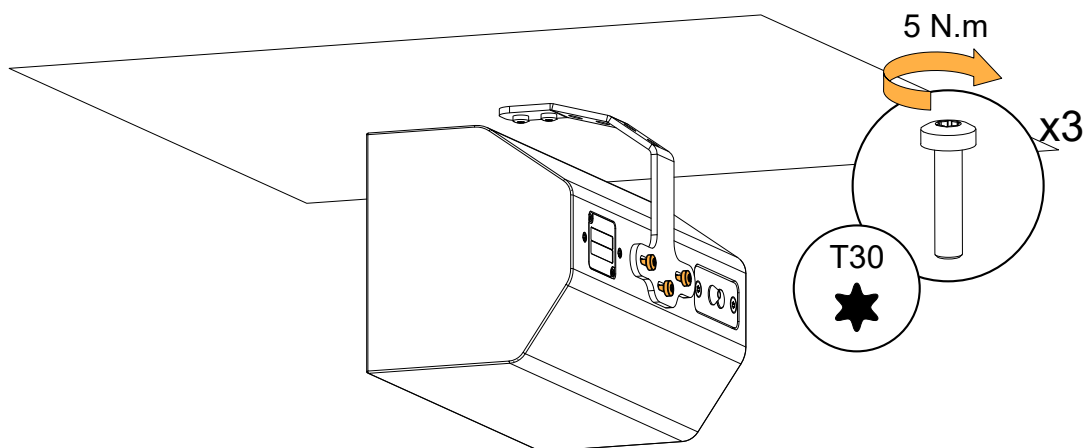

6. Prepare X8i cabling. Refer to [Cabling X8i](#) (p.171).

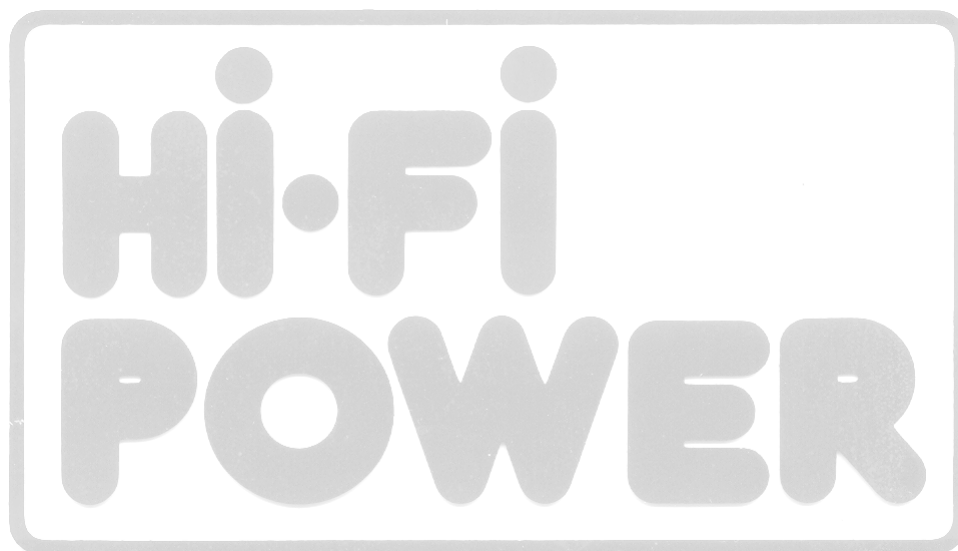

Flying X8i with X8i-HBAR

About this task

X8i site angles when flown or truss-mounted with X8i-HBAR

hole N°	angle
1	9°
2	1°
3	-10°
4	-20°
5	-30°
6	-40°

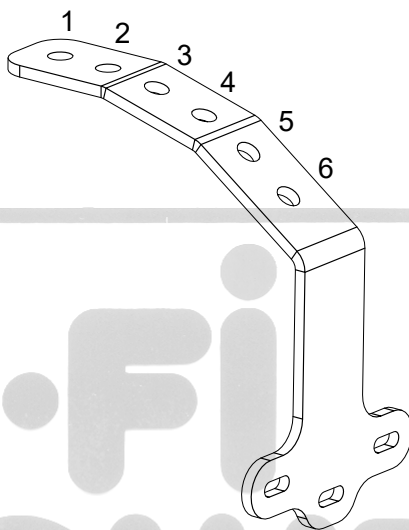

Prerequisite

Place X8i on its front face on a clean flat surface.

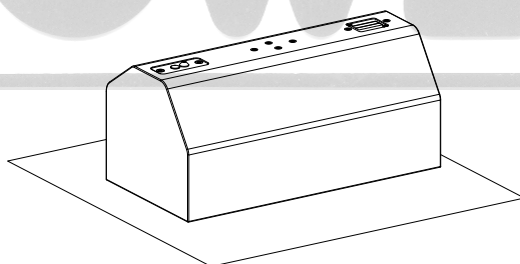
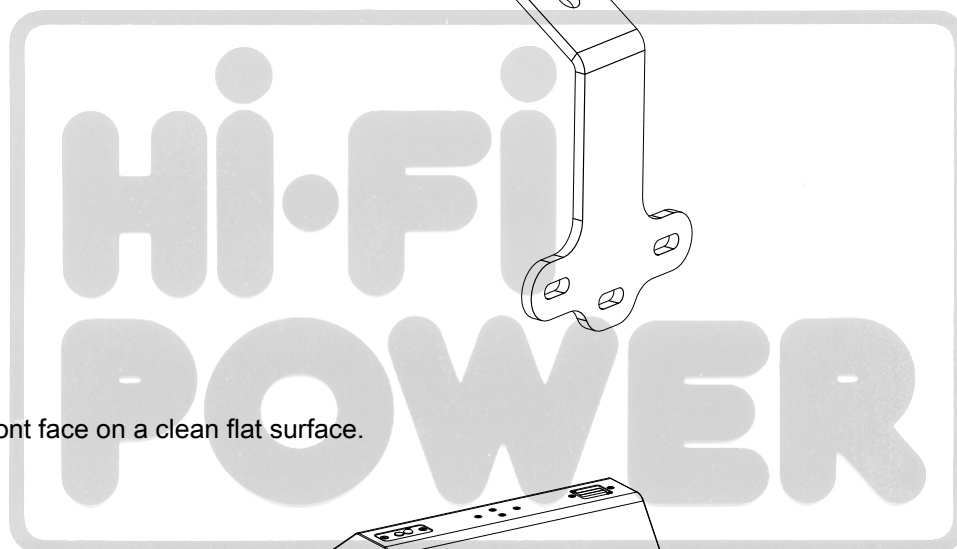

Procedure



Adjust the threaded rod length to avoid any collision with the enclosure.

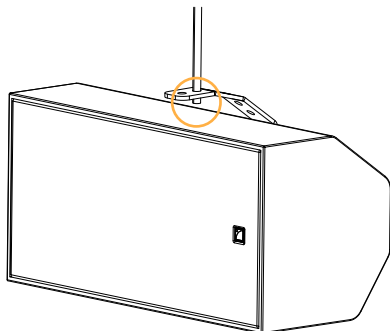

1. Choose the pickup point and secure X8i-HBAR to a truss clamp or to a threaded rod (maximum Ø 10 mm / 0.39 in) using nuts.

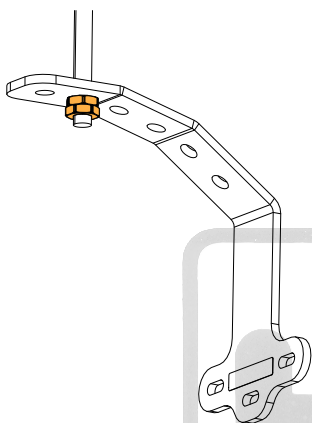

2. Remove the three placeholder screws in the middle of X8i.



X8i-HBAR can be mounted on a horizontal X8i turned either way:

with the connector plate on the right-hand side

with the connector plate on the left-hand side

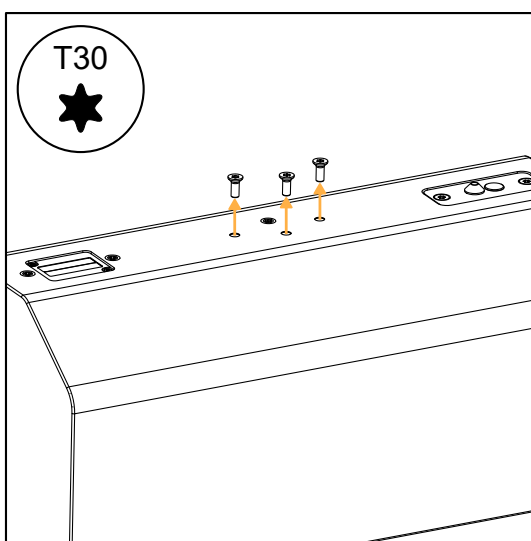
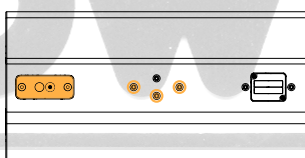
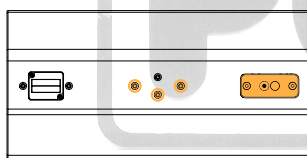



Do not fully tighten the screws.

3. Mount X8i on X8i-HBAR.

Use three M6×25 Torx screws.

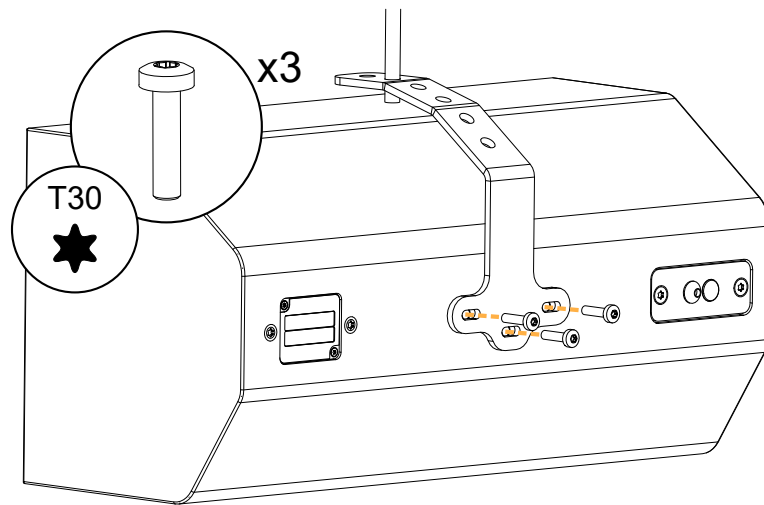

4. Adjust the roll angle.

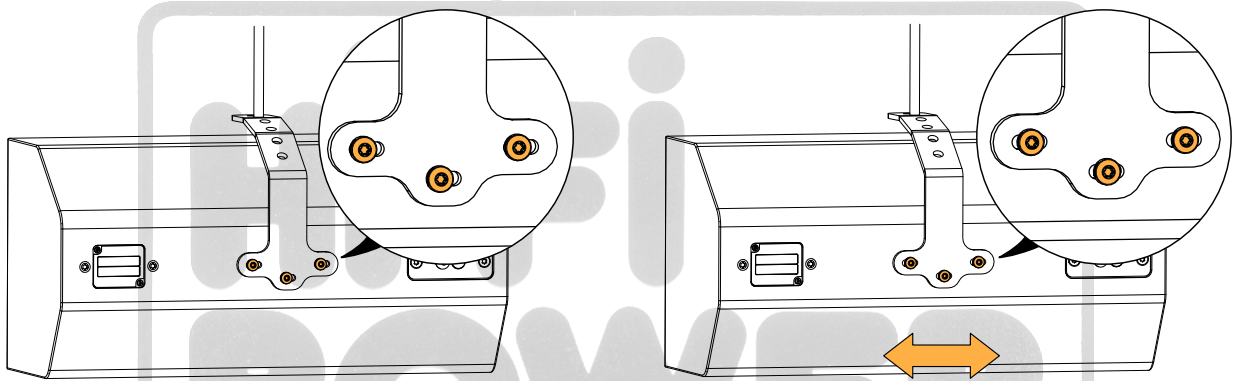

5. Tighten the screws.

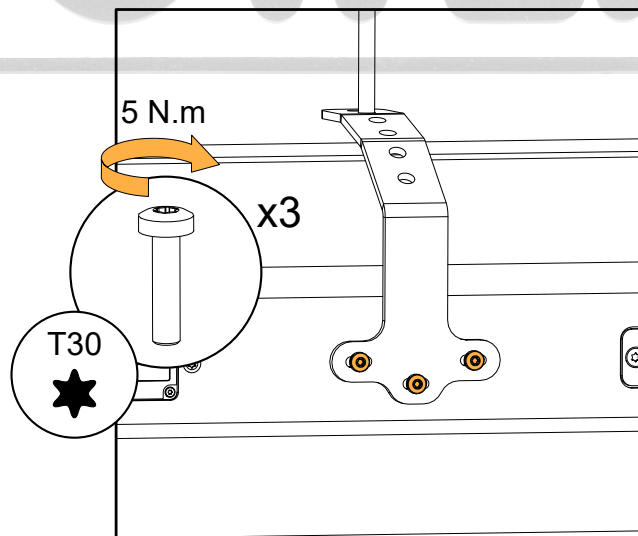

6. Prepare the cabling. Refer to [Cabling X8i](#) (p.171).

Downward-facing

Ceiling-mounting X8i with X8i-onCW

Type of deployment	ceiling-mounting
Rigging accessories	X8i-onCW
Additional material	4 compatible screws and anchors
Tools	torque screwdriver
	T20 Torx bit
	T30 Torx bit
Min. number of operators	2

Secondary safety for flown, wall-mounted, or ceiling-mounted enclosures

Use one insert at the back of the enclosure to implement a secondary safety.

Risk of crushing injury

Ensure that the wall or ceiling can support the load of the product.

It is recommended to mount only on solid structures. If mounting on a hollow structure (such as a wall cavity), place anchoring points on the framework (wall studs, ceiling joists), or reinforce the mounting area.

Select screws and anchors applicable to the wall or ceiling properties and to the load of the product. Prevent screws from loosening over time, using for example thread locker or lock washers.

Specifications for screws and anchors

deployment	accessory	ultimate tensile load per screw (daN)	ultimate shear load per screw (daN)	screws quantity	mounting hole size	specific constraints
ceiling-mounting	X8i-onCW	6	–	4	Ø 6.4 mm / 0.25 in	total thickness with washers: 13.10 mm / 0.51 in

 SPCON cannot be used in this configuration.

Screws and fasteners

from X8i-onCW

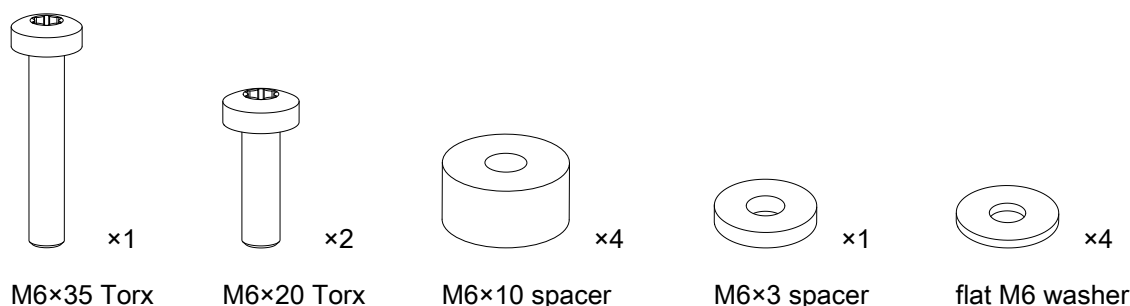

Assembly

About this task



For this configuration, the speaker cable must be run inside the wall or ceiling.

Prerequisite

Place X8i on its front face on a clean flat surface.

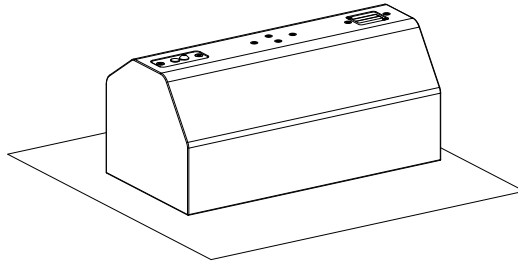

Make sure that the X8i-onCW safety screws are present and loosened.

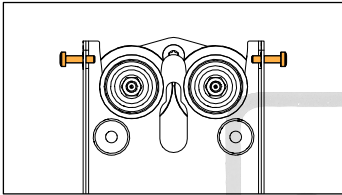

Procedure



Make sure to leave enough space between the walls and the sides of the rigging element to access the screw(s) when the enclosure is mounted.

1. Drill holes in the ceiling for the anchors and for the cable exit(s).

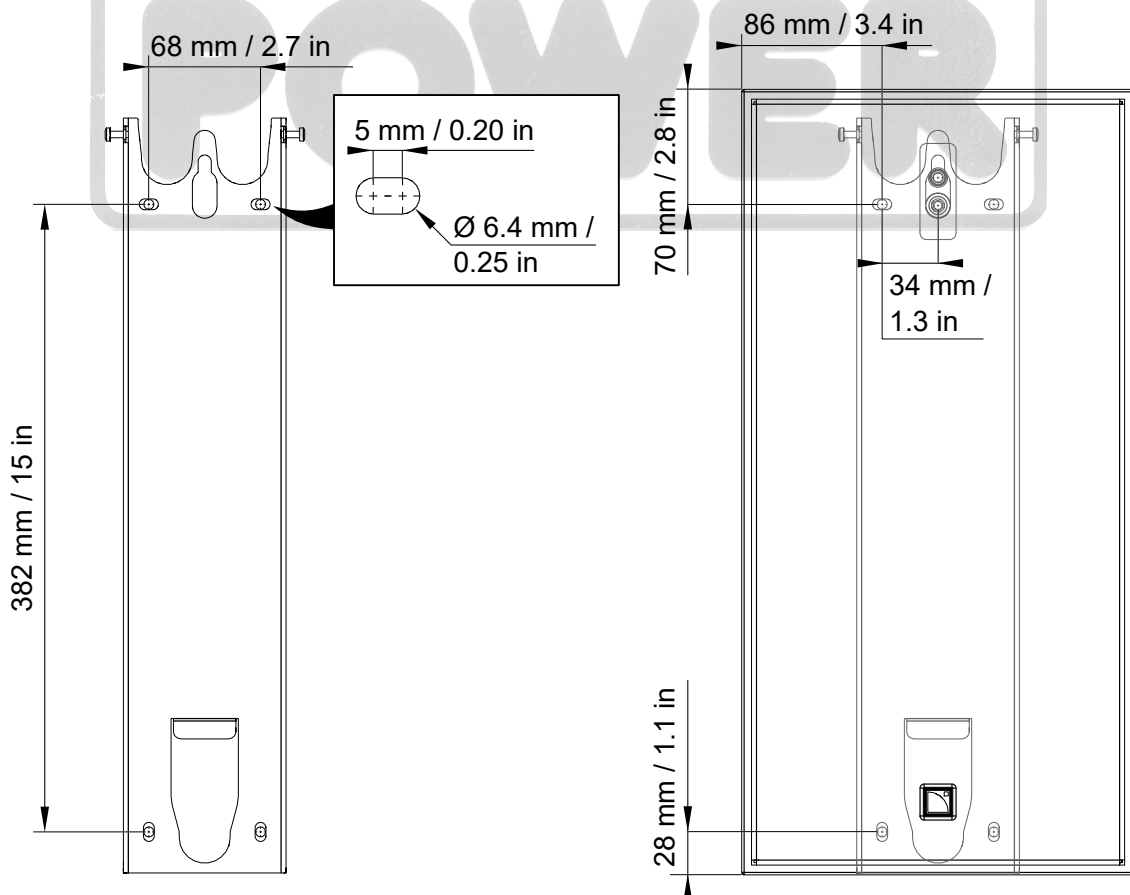

2. Run the speaker cable inside the ceiling.
3. Secure the surface-mounting plate to the ceiling, using the four M6×10 spacers.

If the surface is uneven, adjust with the flat M6 washers.

Run the cable through the top hole of the surface-mounting plate.

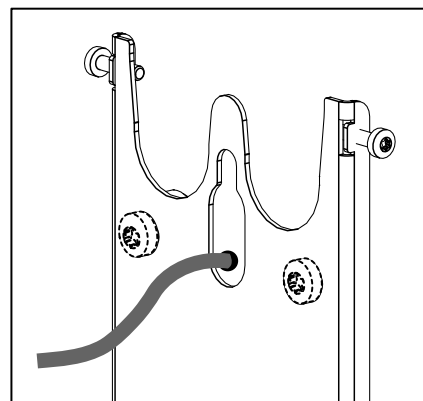
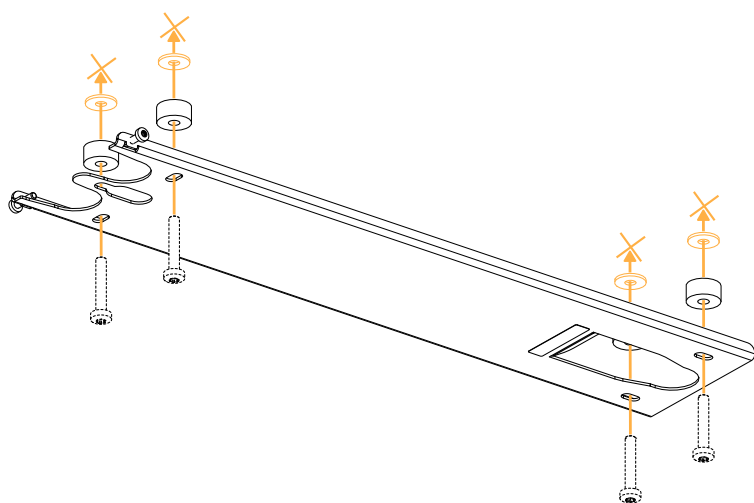

4. Secure the two top silent blocks to X8i:

- a) Remove the connector sealing plate (if present) or the placeholder screws.
- b) Run the cable through the enclosure-mounting plate and through the connector sealing plate.
- c) Connect the cable to the X8i terminal block. Refer to [Cabling X8i](#) (p.171).
- d) Secure the enclosure-mounting plate and the connector sealing plate to X8i.

Use the two M6×20 Torx screws.

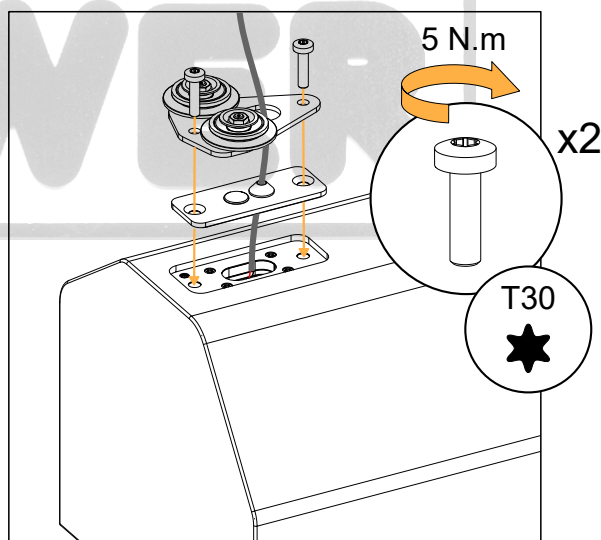
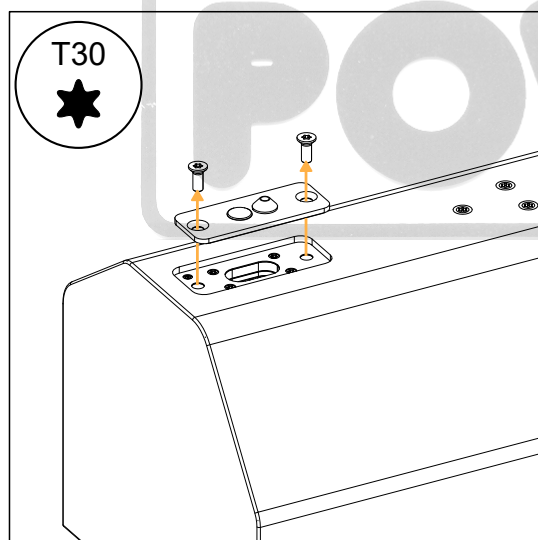

5. Secure the bottom silent block to X8i:

- a) Remove the placeholder screw at the bottom of X8i.
- b) Secure the silent block and the M6×3 spacer at the bottom of the enclosure.

Use the M6×30 Torx screw.

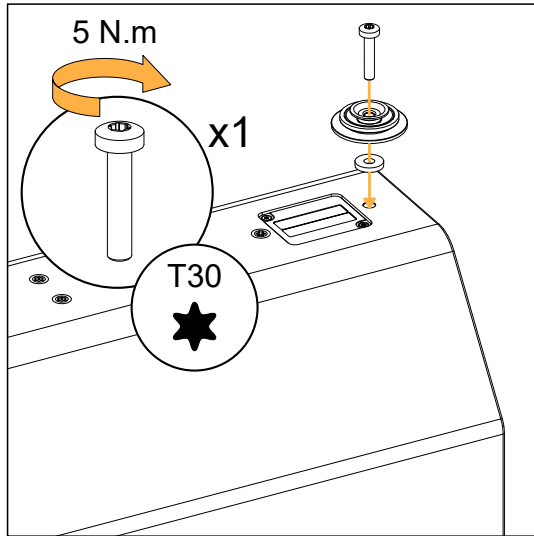
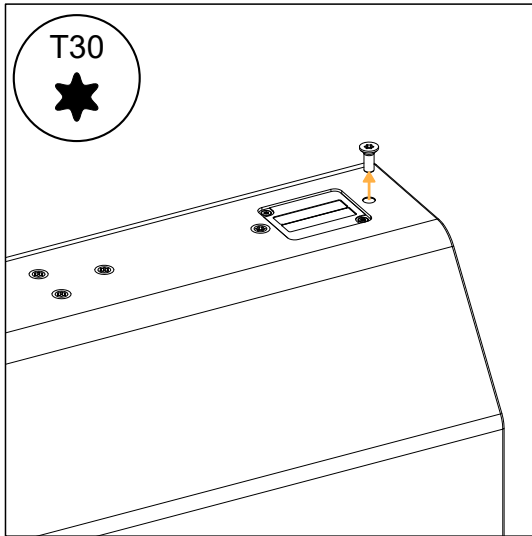

Risk of crushing injury

This step requires two operators.

6. Mount X8i on the ceiling:

- a) Align the silent blocks with the surface-mounting plate cutouts.
- b) Push the assembly towards the bottom of X8i.

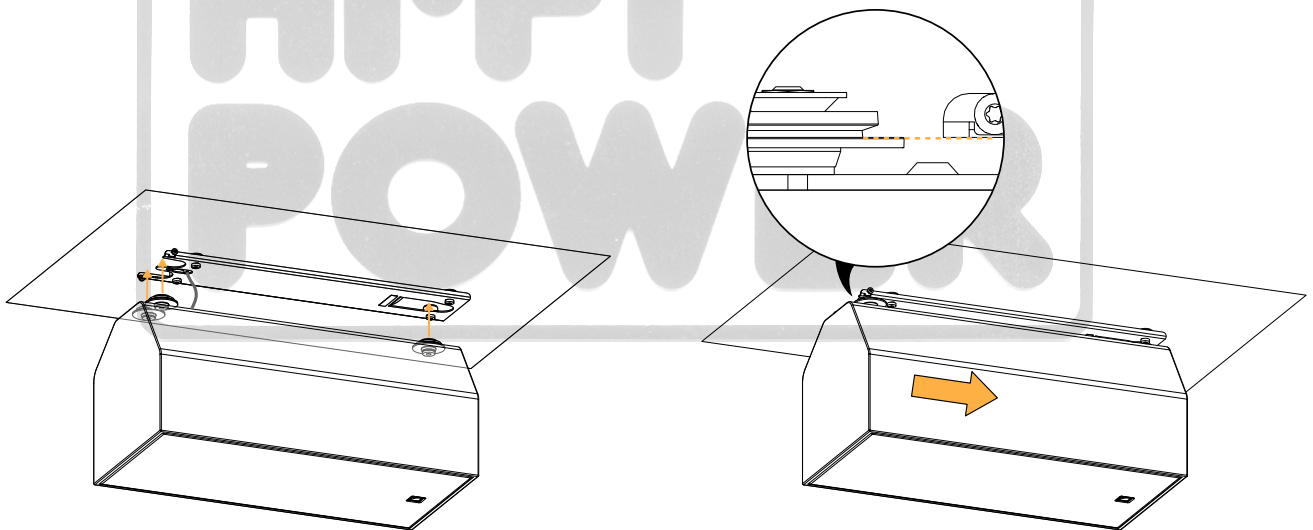

7. Tighten the safety screws on both sides and make sure the assembly is stable.

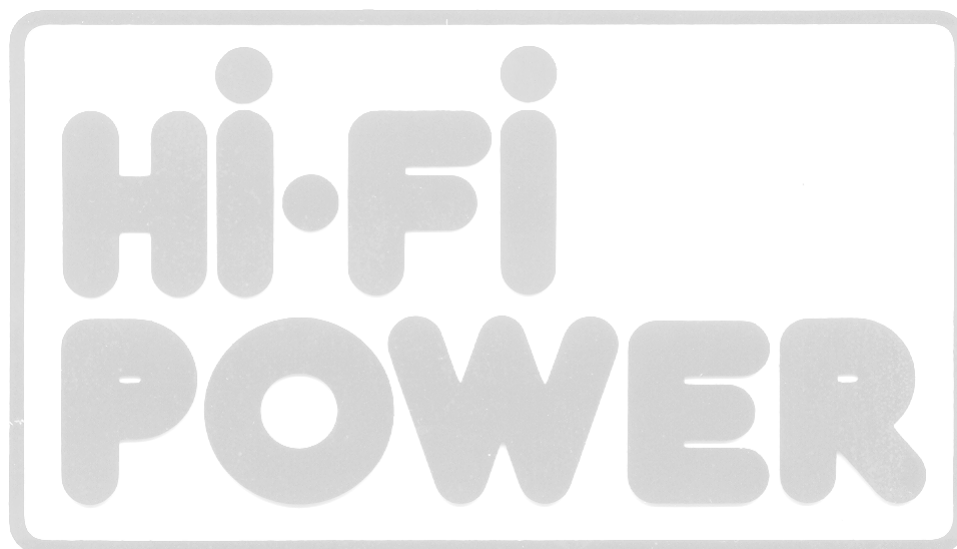
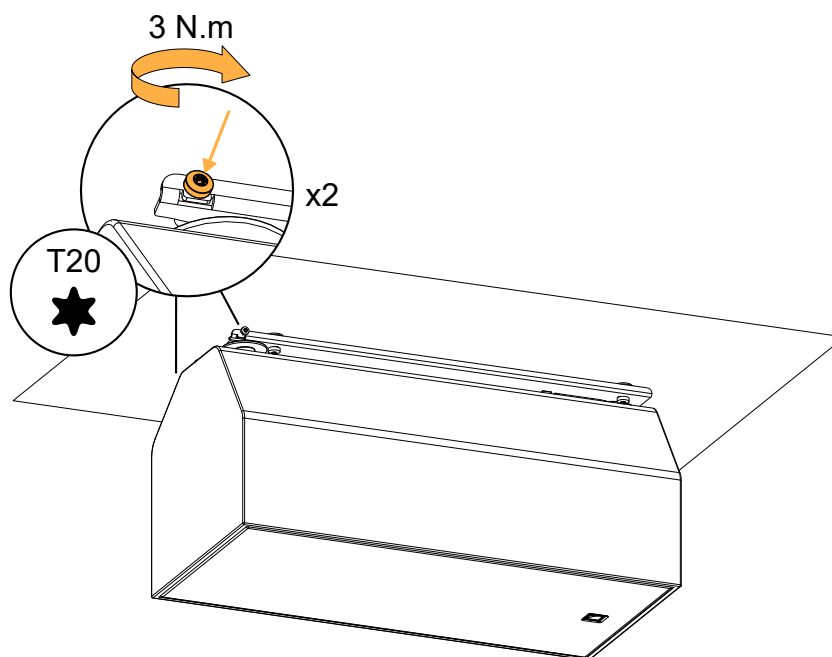

Flying X8i with CEILING-PENDANT

Type of deployment	truss-mounting
Rigging accessories	CEILING-PENDANT
Additional material	1 max. Ø 12 mm / 0.47 in truss clamp, or
	1 max. Ø 12 mm / 0.47 in threaded rod, with corresponding nuts and washers
Tools	torque screwdriver
	T30 Torx bit
Min. number of operators	2

! **Secondary safety for flown, wall-mounted, or ceiling-mounted enclosures**
Use one insert at the back of the enclosure to implement a secondary safety.

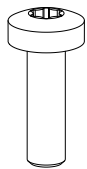
Screws and fasteners*from CEILING-PENDANT*

x2

M6x20 Torx

Assembly**About this task**

! For this configuration, the speaker cable must be run inside the ceiling.

Prerequisite

Place X8i on its front face on a clean flat surface.

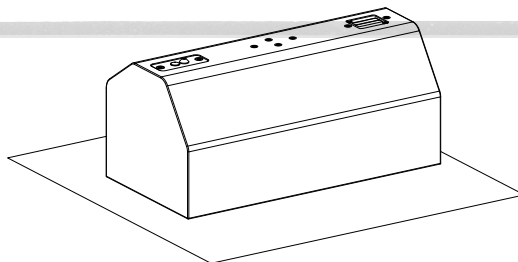

Procedure

1. Remove the two placeholder screws in the middle of X8i.

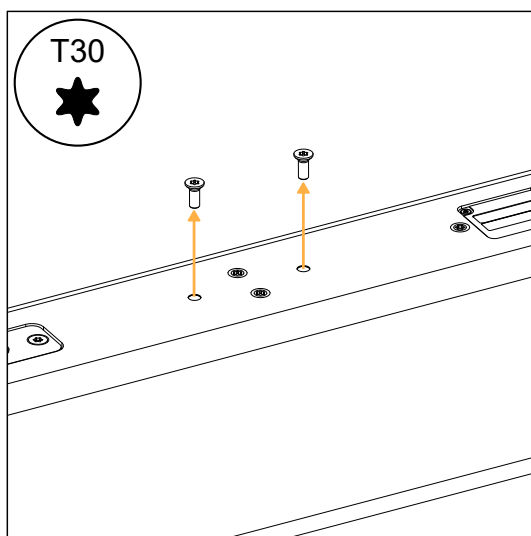

2. Secure CEILING-PENDANT to X8i.
Use two M6×25 Torx screws.

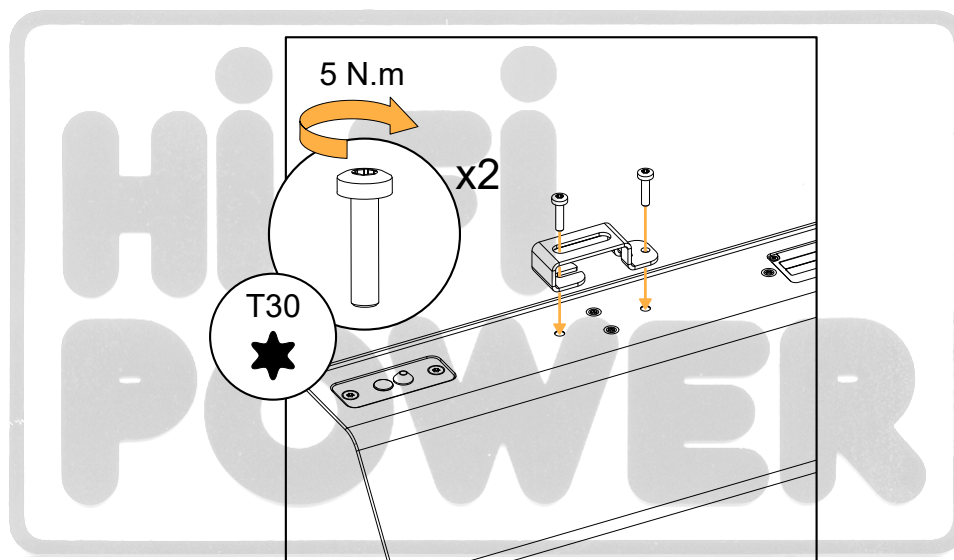

3. Fly X8i with a truss clamp or a threaded rod (maximum \varnothing 12 mm / 0.47 in).
Make sure the assembly is stable.

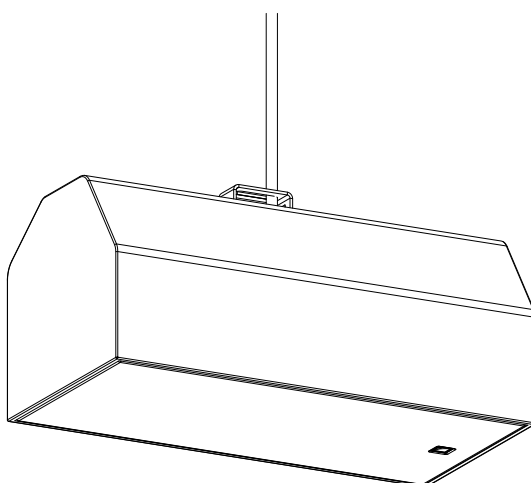

4. Prepare the cabling. Refer to [Cabling X8i](#) (p.171).

Ground-mounting

Overview

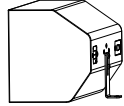
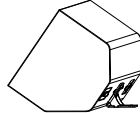
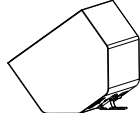
orientation	site angle		
	0°	35°	55°
Vertical	no rigging accessory	–	
Horizontal	GROUND (p.162) 	GROUND35 (p.162) 	GROUND55 (p.162) 

Ground-mounting X8i horizontally with GROUND / GROUND55 / GROUND35

Type of deployment	ground-stacking
Rigging accessories	GROUND / GROUND55 / GROUND35
Additional material	2 compatible screws and anchors
Tools	torque screwdriver
	T30 Torx bit
	screwdriver extension
Min. number of operators	1



SPCON cannot be used in this configuration.

Specifications for screws and anchors

deployment	accessory	ultimate tensile load per screw (daN)	ultimate shear load per screw (daN)	screws quantity	mounting hole size	specific constraints
ground-mounting	GROUND / GROUND35 / GROUND55	–	–	2	Ø 6.4 mm / 0.25 in	–

Screws and fasteners

from GROUND / GROUND55 / GROUND35

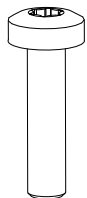

×2

M6×25 Torx

Assembly

About this task

i In this procedure, GROUNDxx designates the ground-mounting accessories GROUND55, GROUND35, and GROUND.

Prerequisite

Place X8i on its front face on a clean surface:

- For GROUND55 (55° site angle): with the connector plate on the right.

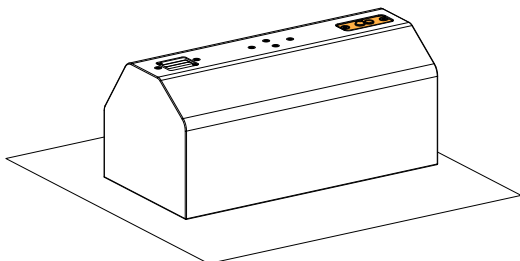

- For GROUND35 (35° site angle) : with the connector plate on the left.

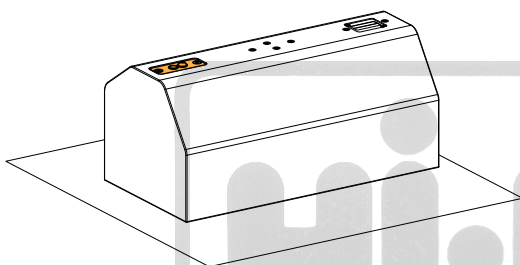

- For GROUND (0° site angle): turned either way.

Procedure

1. Remove one placeholder screw for GROUND or two for GROUND55/GROUND35, in the middle of X8i.

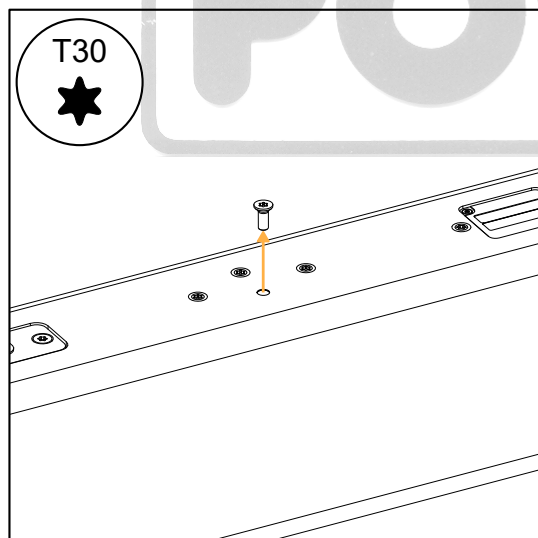

GROUND

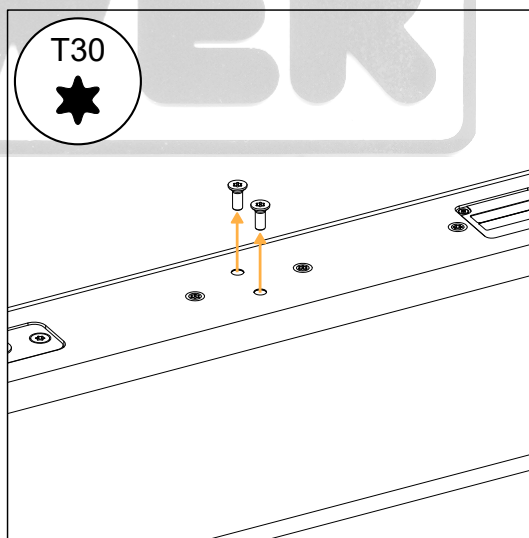

GROUND55/GROUND35



Do not fully tighten the screws.

2. Mount GROUNDxx on X8i.

Use one M6×25 Torx screw (GROUND) or two M6×25 Torx screws (GROUND55/GROUND35).

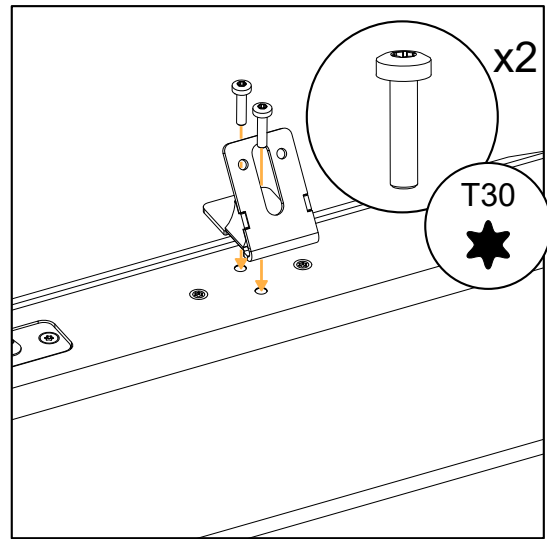
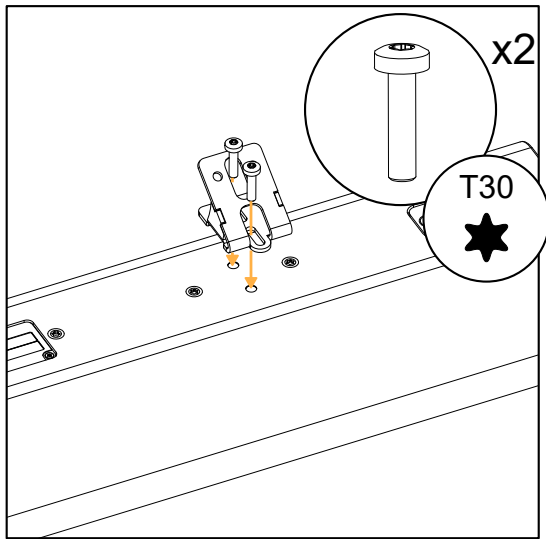

GROUND55

GROUND35

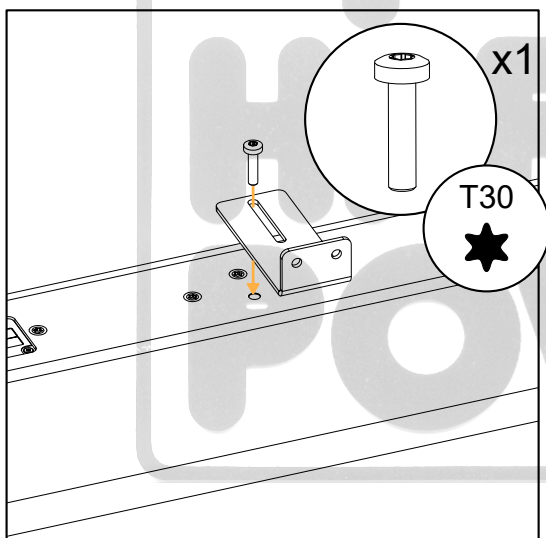

GROUND

3. Place X8i in monitor position, with GROUNDxx resting on the ground.

Make sure that GROUNDxx is aligned with the cabinet. Make adjustments if necessary.

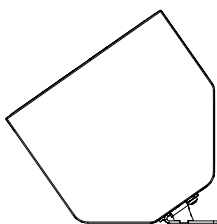

GROUND55

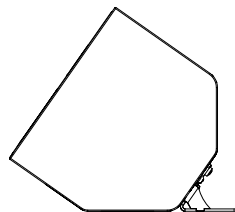

GROUND35

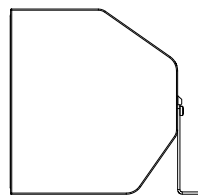

GROUND

4. Place X8i on its front face and tighten the screws.

Use a screwdriver extension.

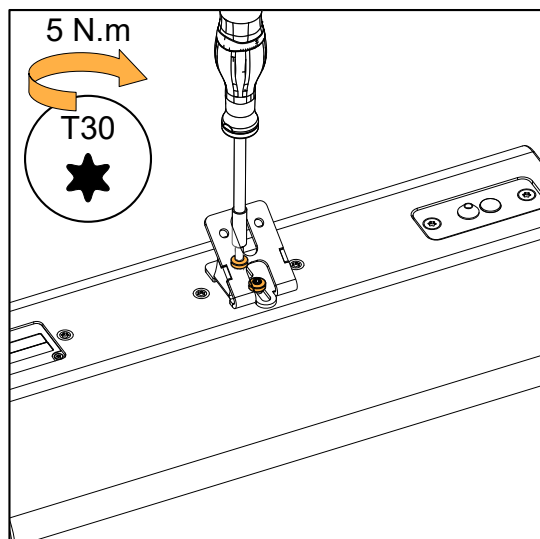

GROUND55

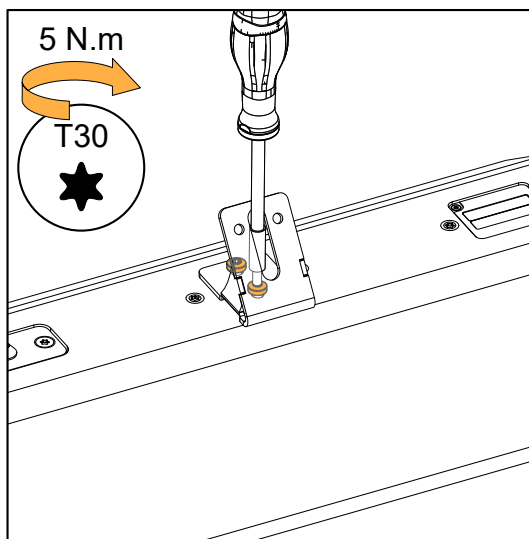

GROUND35

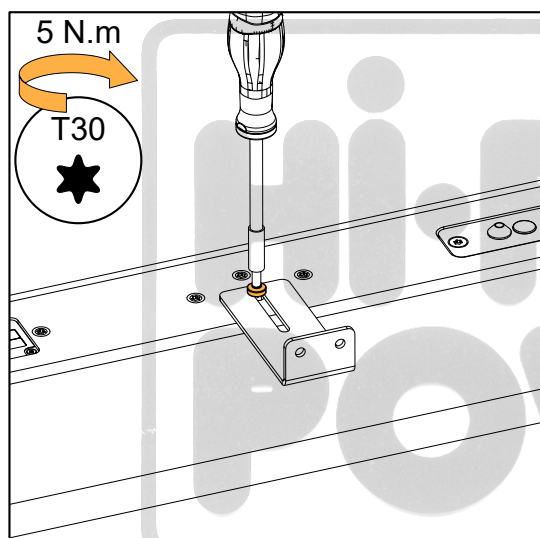

GROUND

5. Place X8i at its final location and secure GROUNDxx to the ground.

Make sure the assembly is stable.

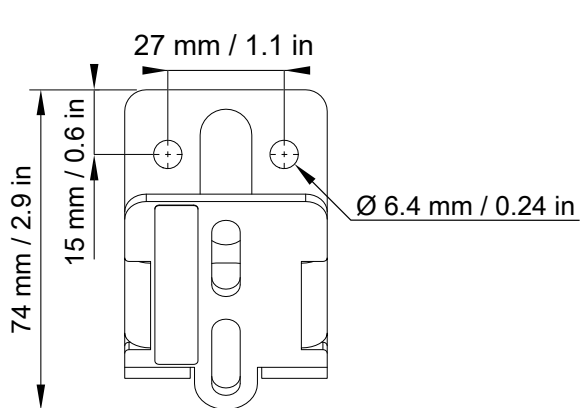

GROUND55

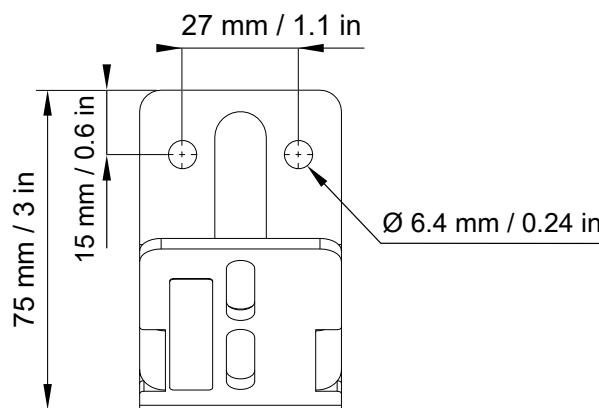

GROUND35

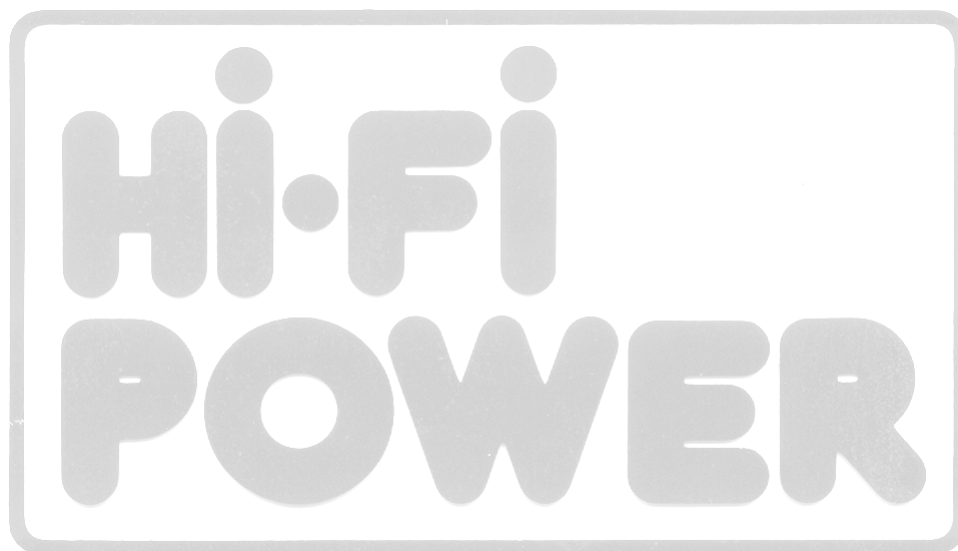
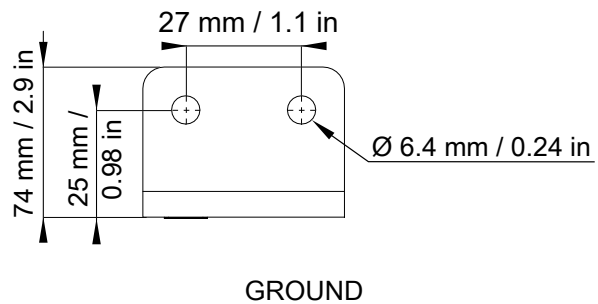

Pole-mounting

Pole-mounting X8i with POLE

Type of deployment	pole-mounting
Rigging accessories	POLE
Additional material	Ø 35 mm (1-3/8") pole
Tools	torque screwdriver
	screwdriver extension
	T30 Torx bit
	17 mm wrench
Min. number of operators	1

Assembly

Procedure

1. Remove the two placeholder screws in the middle or at the bottom of X8i.

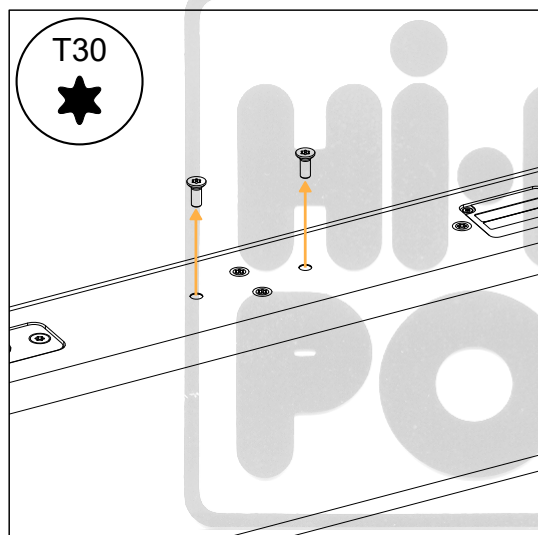

- Secure POLE to X8i with the two captive screws.

Use a screwdriver extension.

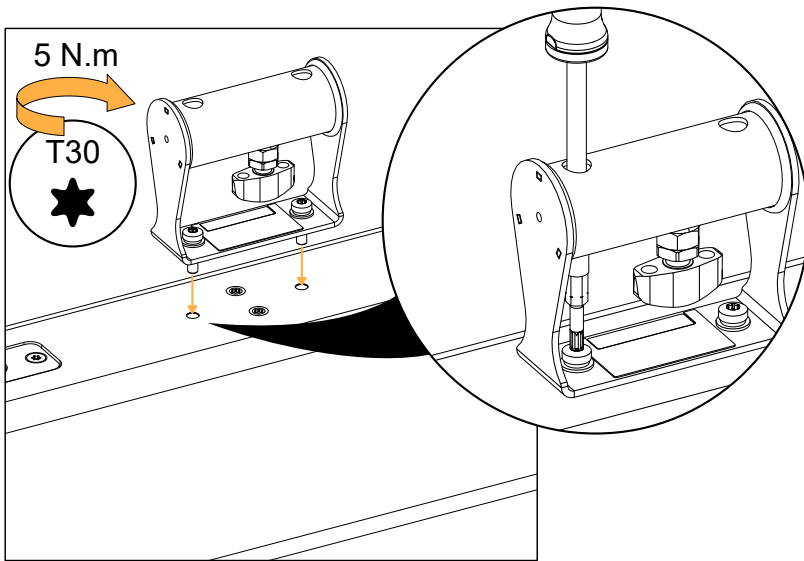

- Mount the assembly on a $\varnothing 35$ mm (1-3/8") pole.

Use a screwdriver extension.

- Tighten the locking knob and the nut.

Make sure the assembly is stable.

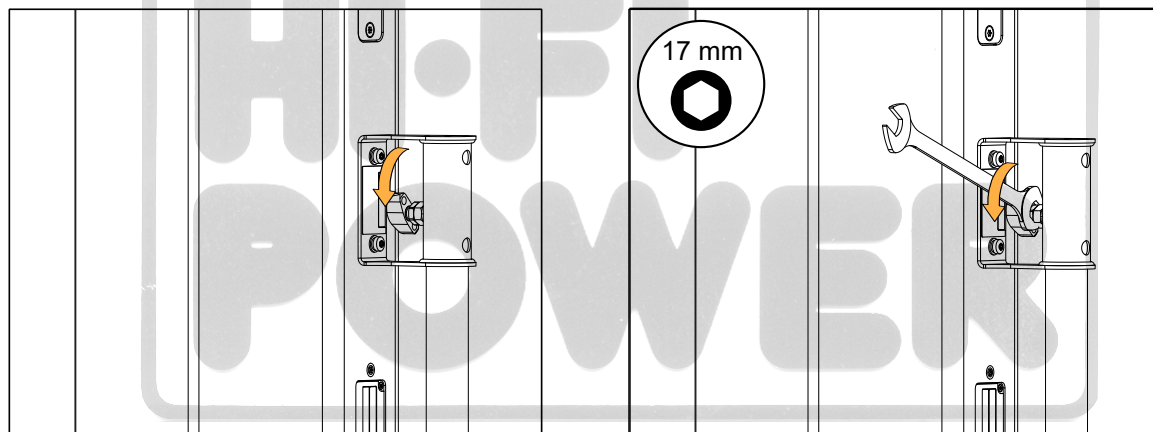

Connection to LA amplified controllers

! Refer to the **Amplification reference** technical bulletin for the latest information on compatibility with amplified controllers and cabling schemes for all enclosure types.

Enclosure drive capacity per amplified controller

Make sure the total number of connected enclosures does not exceed the maximum number of enclosures per controller (refer to the footnotes).

	LA2Xi	LA4X	LA7.16i	LA12X
	per output* / total	per output* / total	per output* / total ^a	per output* / total
X8i	2 / 8 (SE), 1 / 2 (BTL)	2 / 8	1 / 16	3 / 12

i Reduced maximum SPL or drive capacity with LA2Xi: refer to the **LA2Xi owner's manual**.

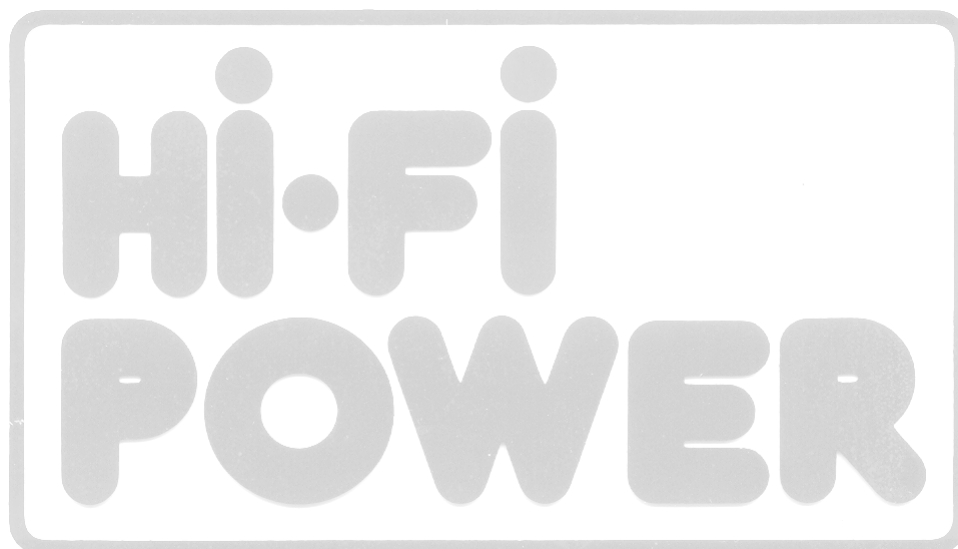

* For passive loudspeakers, the value corresponds to the number of enclosures in parallel on the output. For active loudspeakers, the value corresponds to the number of sections in parallel on the output.

^a Given for nominal use, assuming that all channels are driven at full power. When sending the same signal to all outputs, never exceed the maximum numbers, regardless of the Power Budget values, otherwise the Fuse Protect algorithm may be triggered. When powered by a 100 V power supply, reduce the number of enclosures in order not to exceed 75% of the power gauge.

Cabling schemes for X8i

Refer to the cabling schemes to connect the enclosures to different types of output configurations.



Refer to the cable manufacturer documentation for the wire color code.



Refer to the **LA2Xi owner's manual** for more information on output configurations.

Terminal block output (LA2Xi SE / LA7.16i)

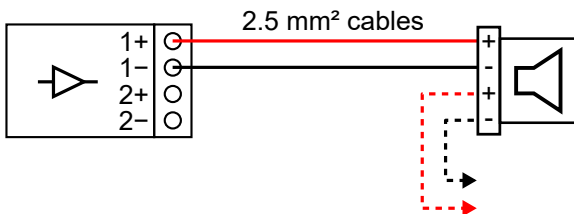

Terminal block output (LA2Xi BTL)

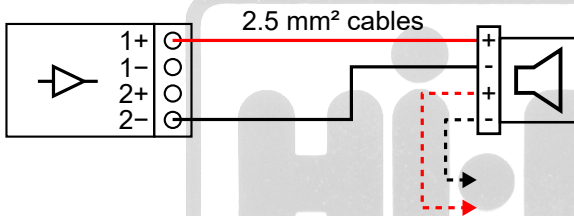

One-channel speakON output

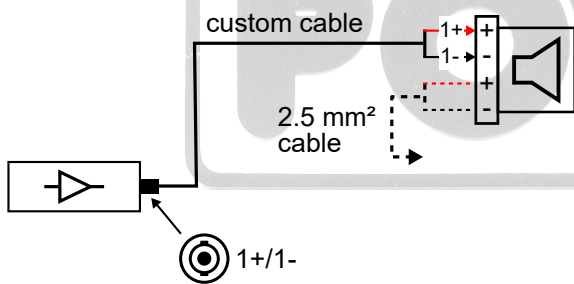

Two-channel speakON output

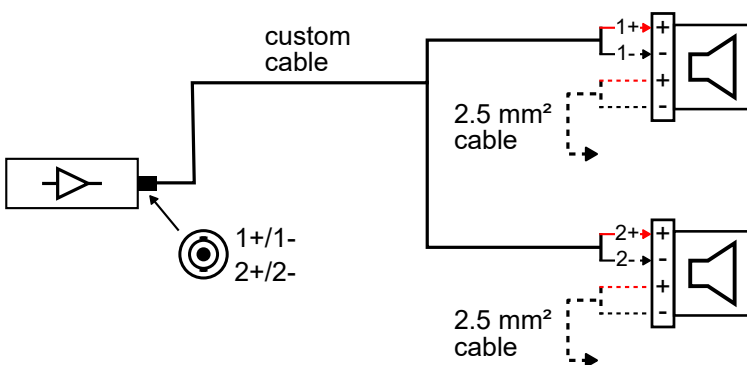

Cabling X8i

Accessory	connector sealing plate (provided)
Screws and fasteners	2 M6×16 screws (mounted on enclosure)
Tools	torque screwdriver
	T30 Torx bit
	small tool or flat screwdriver (3 mm or less)
Additional material	recommended: insulated cable ferrules and crimping tool
Min number of operators	1

Specifications for insulated cable ferrules

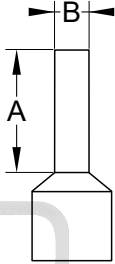
Wire range	14 AWG / 2.5 mm ²		
Maximum electric current	30 A		
Maximum electrical rating	105 °C (221 °F) / 600 V		
Terminal material	tin-plated copper		
Dimensions	A	12 mm / 0.47 in	
	B	2.5 mm / 0.10 in	

HI-FI
POWER

Cabling

Prerequisite



The cable glands on the connector sealing plate are compatible with cables up to $2 \times 2.5 \text{ mm}^2$ gauge.

Refer to:

- [APPENDIX B: Recommendation for speaker cables](#) (p.210)
- [Cabling schemes for X8i](#) (p.170)

About this task

The connector sealing plate has two holes: one for the input cable and one for the cable connecting to the next enclosure in parallel. By default, the first hole is fitted with a cable gland and the second one with a protective plug. An extra cable gland is provided with each enclosure.

This procedure describes how to connect the input cable to the enclosure. If the enclosure must be connected in parallel, replace the protective plug with the extra cable gland and proceed identically for both cables.

Procedure

1. Remove the connector sealing plate (if present) or the placeholder screws.

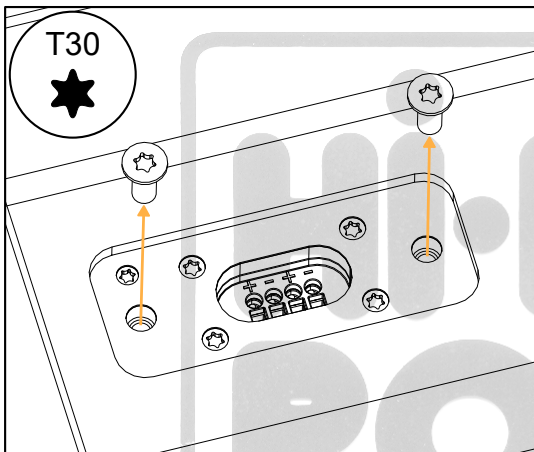

2. Insert the cable through the cable gland.

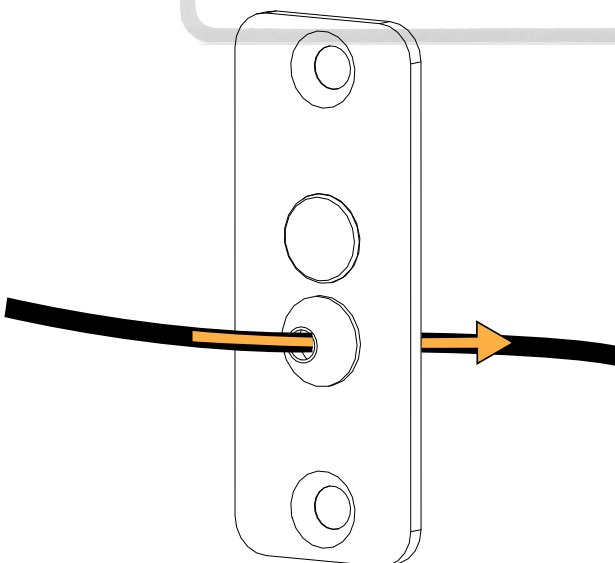

3. Strip the wires of the cable.

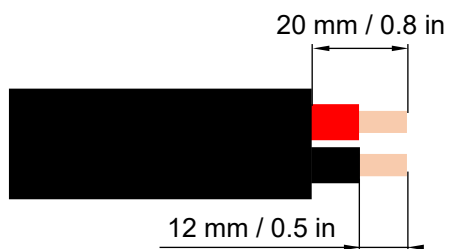

2 × max. 2.5 mm² cable



It is recommended to crimp insulated ferrules at the end of both wires.
See [Specifications for insulated cable ferrules](#) (p.171).



Refer to the cable manufacturer documentation for the wire color code.

4. Push the wires into the terminals.

If necessary, use a small tool in the hole next to the terminal to unlock it.

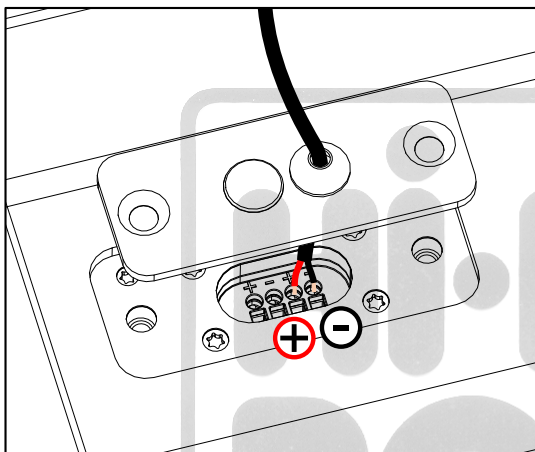

5. Secure the connector sealing plate to the enclosure.

Apply a torque of 3 N.m.

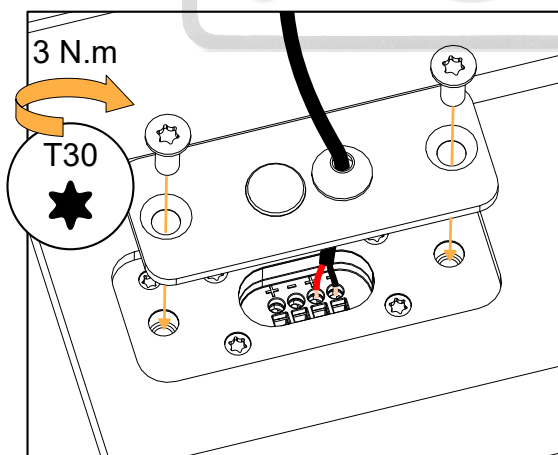

What to do next

To remove the cables, use the small tool to unlock the terminals and pull on the wires.

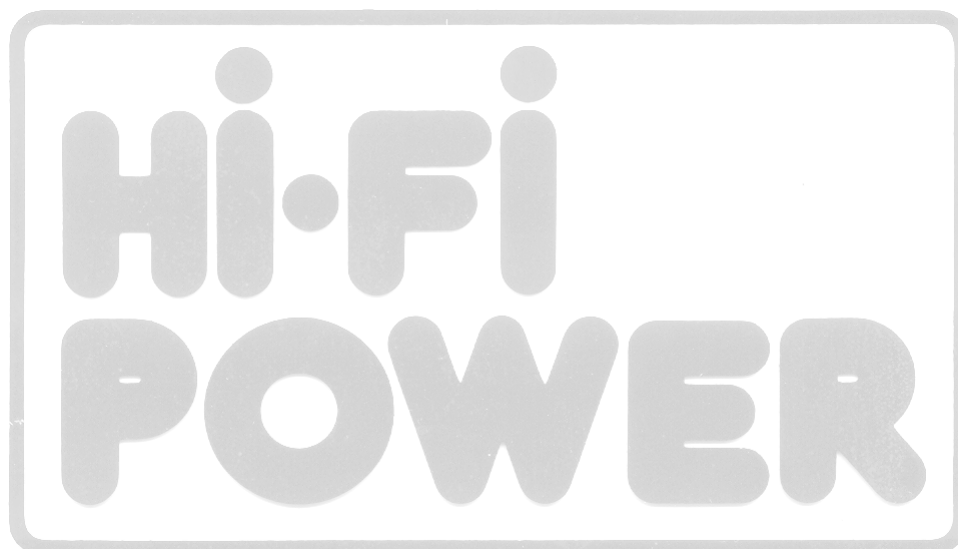
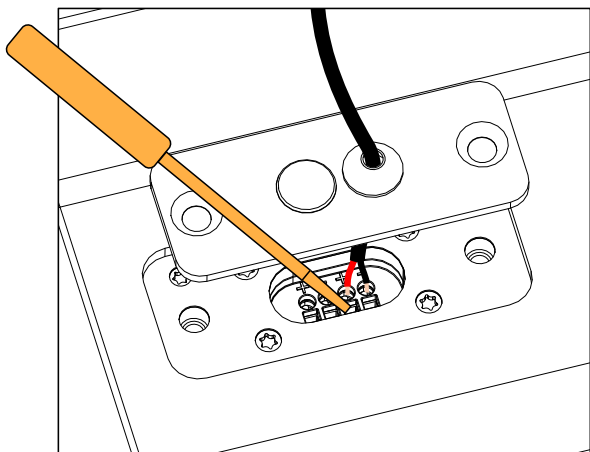

Cabling with SPCON

About this task



Risk of electric shock

When SPCON is connected to an amplified controller, the bare wires carry electrical voltage.

Always mount SPCON to the enclosure **before** connecting the speaker cable to SPCON.

Always disconnect the speaker cable from SPCON **before** removing SPCON from the enclosure.

If the speaker cable cannot be disconnected, unplug the amplified controller from the mains.

SPCON is **not compatible** with the following rigging accessories:

- X8i-onCW
- WALLx2
- PANx2
- GROUND55
- GROUND35
- GROUND

Procedure

1. Remove the connector sealing plate (if present) or the placeholder screws.

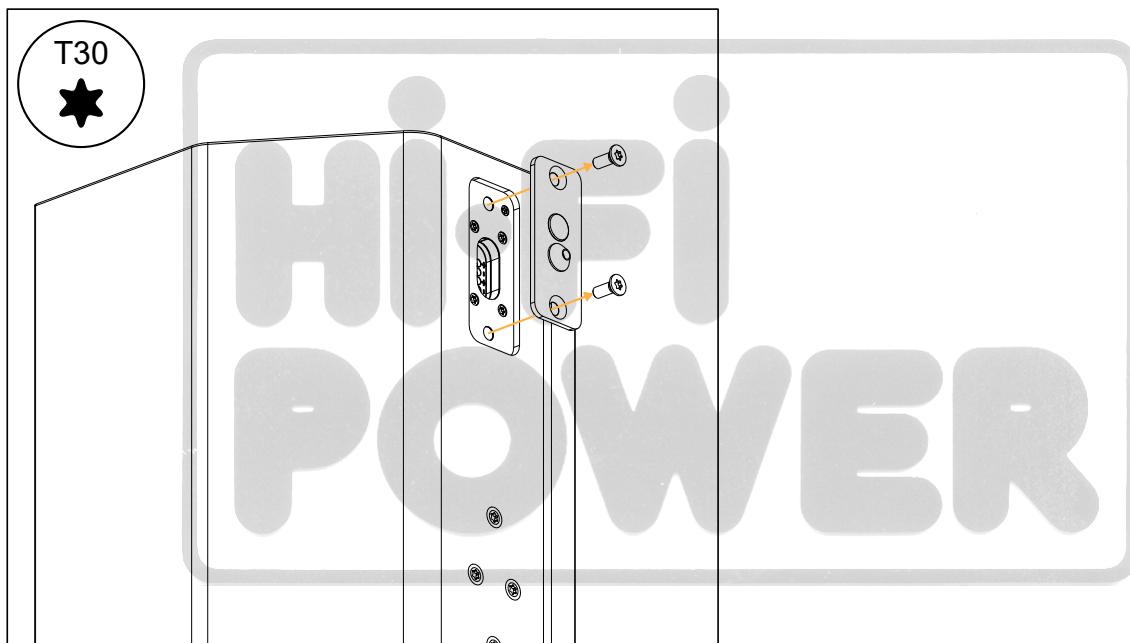

2. Push the SPCON ferrules into the terminals.

If necessary, use a small tool in the hole next to the terminal to unlock it.

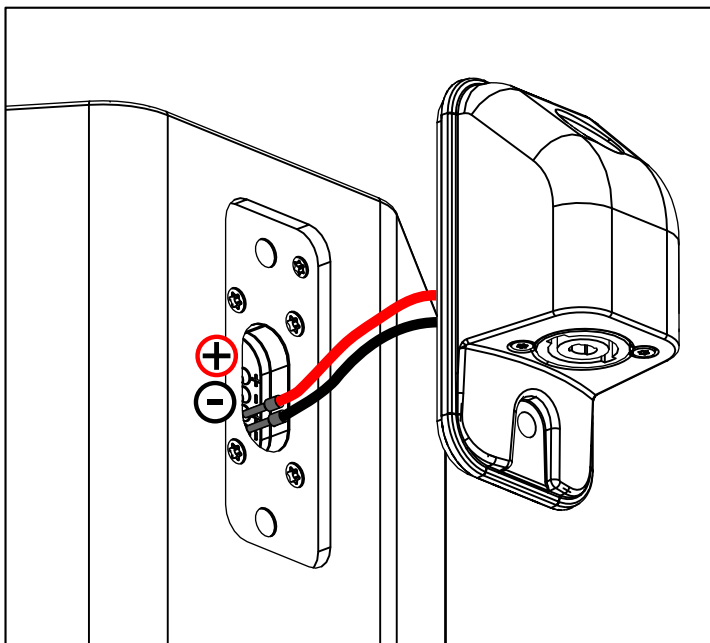

3. Secure SPCON to X8i.

Use the two provided M6×25 Torx screws.

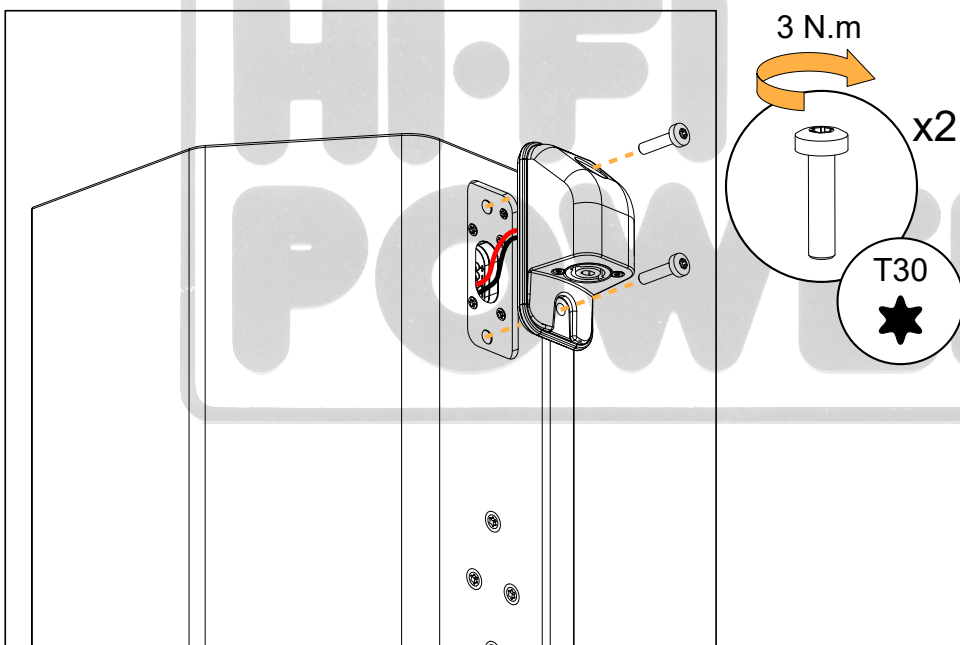

4. Connect the speaker cable to SPCON.

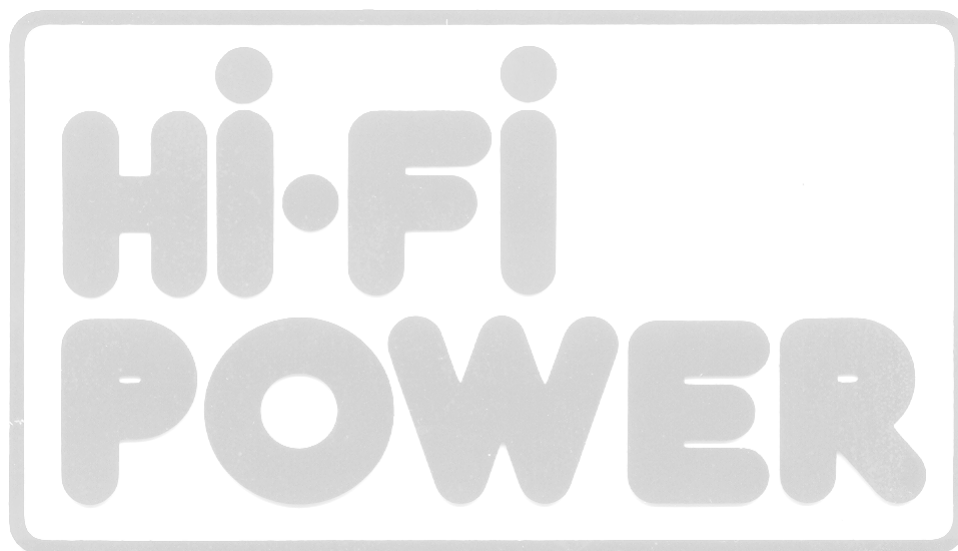
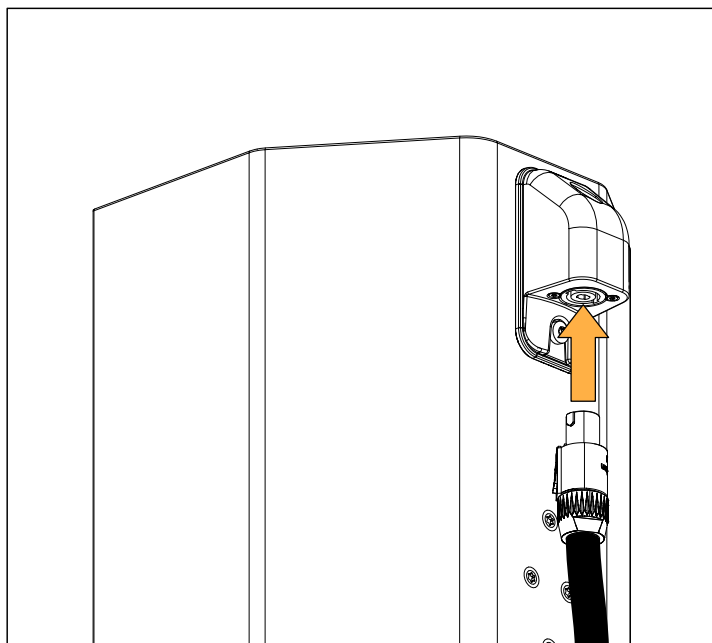

Corrective maintenance

Introduction

This section contains the following maintenance procedures:

X8i

- [D/R - Grill](#) (p.180)
- [D/R - Coaxial loudspeaker](#) (p.181)
- [D/R - Diaphragm](#) (p.182)

For advanced maintenance, contact your L-Acoustics representative.

Tools and consumables

Before performing maintenance on this product, make sure all the tools listed are available. References are given for FACOM® products in this table. Other manufacturers can be used.

name	reference	distributor
set of 6-point 1/4" sockets *	RL.NANO1 / R.360NANO	FACOM
torque screwdriver (2 - 10 N.m) *	A.404	FACOM
torque screwdriver (0.5 - 2.5 N.m) *	A.402	FACOM
flat tool	-	-
trim clip removal pliers	-	-
compressed air blower	-	-

i *included in the L-Acoustics Maintenance Toolcase.

Maintenance Toolcase

The Maintenance Toolcase is a carry-on suitcase that includes all the tools required to perform maintenance on L-Acoustics products. This toolcase is aimed at Certified Providers.

The Maintenance Toolcase uses a Peli™ 1510 Protector case that features three pre-cut layers of foam to safely fit the tools. The Maintenance Toolcase includes tools manufactured by FACOM®, Fluke®, Tohnichi, ABUS, and Würth.

i All third-party trademarks, registered trademarks, or product names are the property of their respective owners.

Exploded views

In order to operate, follow the order outlined here. Each assembly refers to the corresponding Disassembly/ Reassembly (D/R) procedure and the necessary repair kit (KR).



Using the G03895 reconing kit

Follow the instructions to remove the LF speaker from the enclosure.

Perform the reconing procedure according to the information provided by the manufacturer.

Use the screws and fasteners provided in G03895 for reassembly.

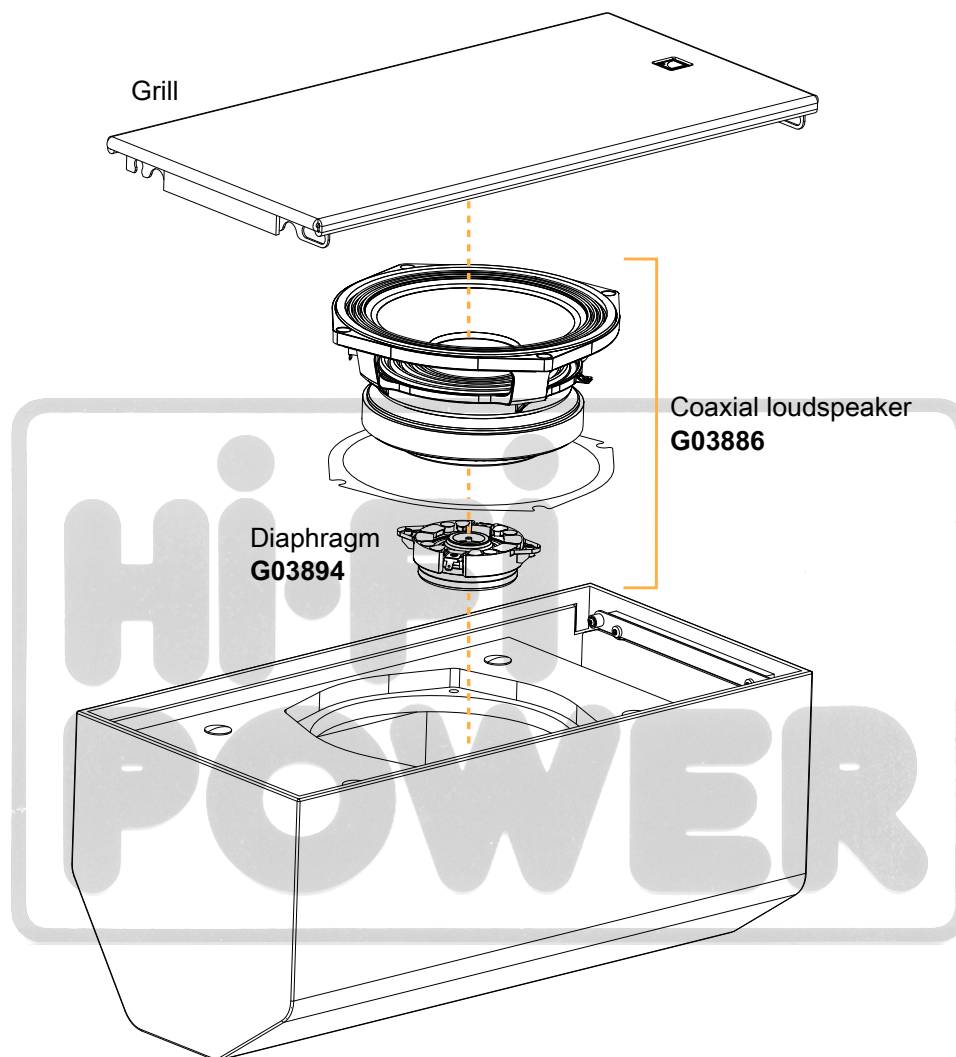

Disassembly and Reassembly procedures

D/R - Grill

Tools

- flat tool

Procedure

1. Use a flat tool as a lever to unlock the grill from each side of the enclosure.

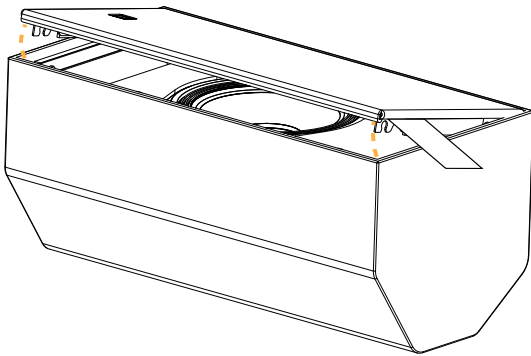

2. Pull the grill forwards and slide it up.

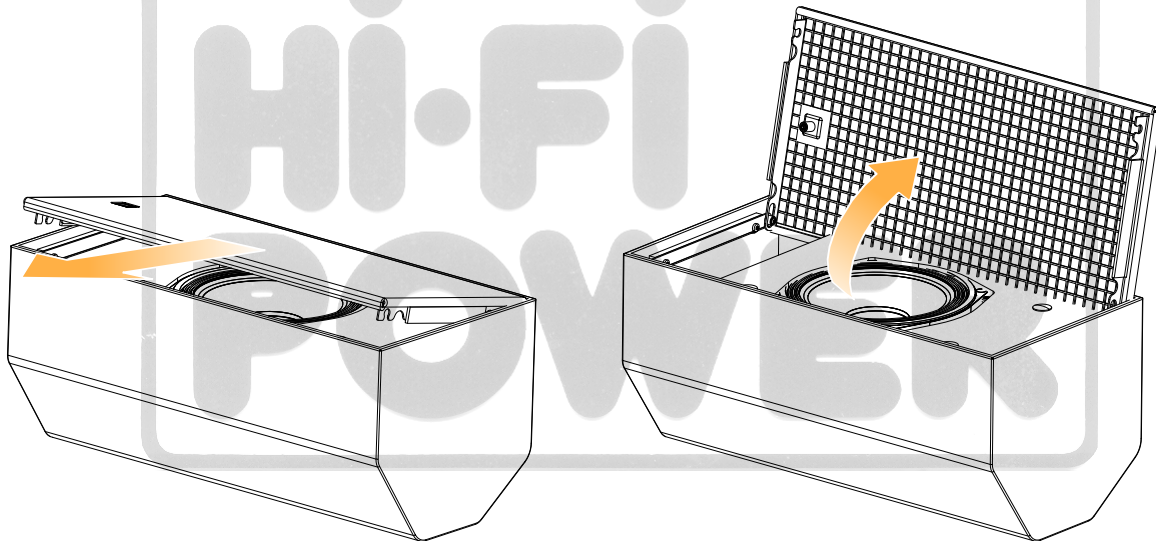

D/R - Coaxial loudspeaker

Tools

- torque screwdriver
- T25 Torx bit

Repair kit

G03886

KR coaxial speaker (8" LF + 1.5" HF diaphragm) X8i

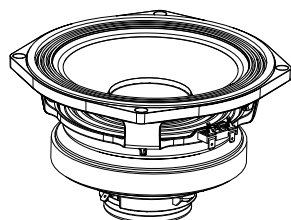

x1

18466_2

8" coaxial speaker - 8 ohms

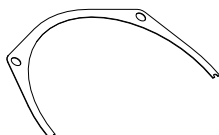

x2

100604

8" speaker gasket



x4

S100053

M5x20 Torx

Prerequisite

Grill removed.

See [D/R - Grill](#) (p.180).

Exploded view



For safety reasons, always use the new screws and spare parts provided in the KR.
If no new screws are available, use blue threadlocker.



Gradually tighten the screws following a star pattern.



If the speaker gasket is damaged, remove and replace it.

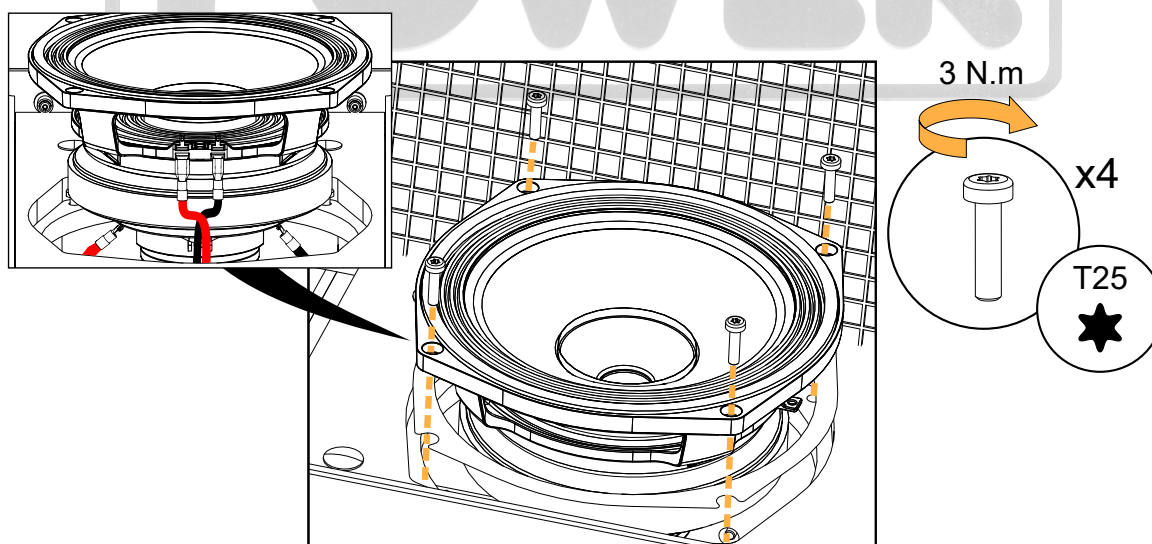

What to do next

Perform the procedures [Acoustical check](#) (p.185).

D/R - Diaphragm

Tools

- torque screwdriver
- 3 mm hex bit
- 3 mm hex wrench
- flat screwdriver

Repair kit

G03894

KR diaphragm 1.5" X8i

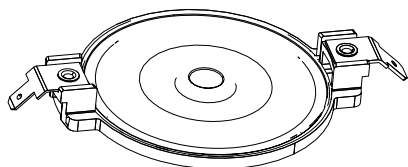

×1

17704

X8 diaphragm assembly



×1

-

driver gasket



×4

S182

M4×12 hex

Prerequisite

Grill removed.

See [D/R - Grill](#) (p.180).

Coaxial speaker removed.

See [D/R - Coaxial loudspeaker](#) (p.181).

The speaker is placed on a flat surface in a dust-free environment.

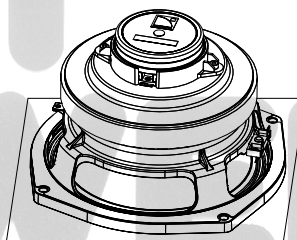

Disassembly

Procedure

1. Pierce the label covering the center screw.
Use the flat screwdriver.

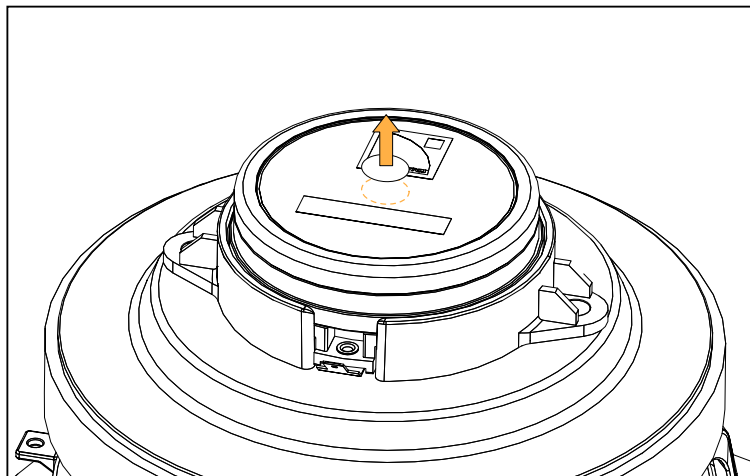

2. Remove the two screws securing the HF driver.
Use the 3 mm hex bit.

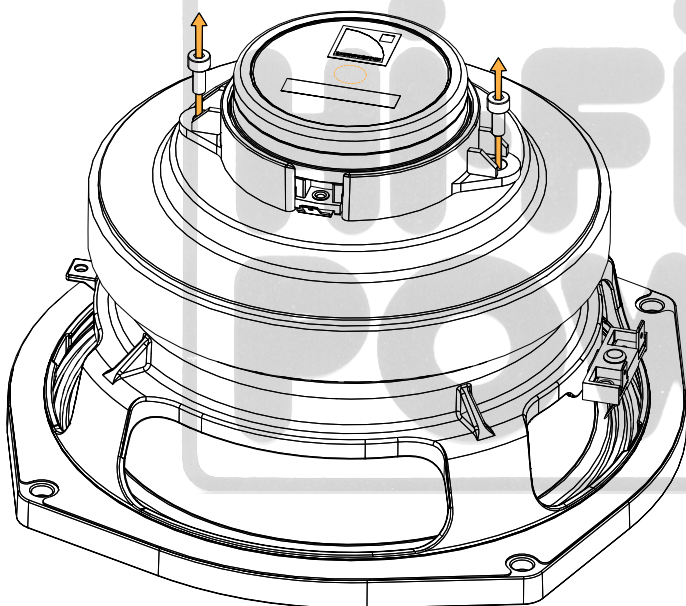

3. Remove the HF driver and remove the gasket between the HF and LF driver.
4. Place the HF driver on a flat surface.
5. Remove the four screws securing the cover and remove the cover.
Use the 3 mm hex bit.
6. Remove the center screw while holding the cone in place.
Use the 3 mm hex bit.



Discard the paper disk to avoid parasitic vibrations.

7. Remove the cone.
8. If there are shims under the cone, carefully remove them.
Take note of how many and what kind of shims are present.
9. Carefully remove the diaphragm holding it by the connectors.

Reassembly

About this task



For safety reasons, always use the new screws and spare parts provided in the KR.

Procedure

1. Clean the driver and the air gap.
Use a blower or double face adhesive tape to clean any particle.
- 
 Make sure the air gap is perfectly clean before moving to the next step.
2. Carefully place the diaphragm.
3. Position the diaphragm using the screw holes as reference points.
The connectors must be positioned halfway between two screw holes.
4. Place the same kind and number of shims that were initially present.
5. Place the cone in the middle.
6. While holding the cone in place, drive the center screw manually using the 3 mm hex wrench.
7. Secure the cover with four S182 screws.
 - a) Gradually secure each screw manually with the 3 mm hex wrench.
Follow a star pattern.
 - b) Tighten the screws in the same order with the torque screwdriver.
Use the 3 mm hex bit. Set the torque to 1.7 N.m.
8. While holding the cone in place, tighten the center screw with the torque screwdriver.
Use the 3 mm hex bit. Set the torque to 1.7 N.m.
9. Place the gasket on the LF driver.
10. Carefully position the HF driver on the LF driver.
Use the connectors as reference points. When facing the LF driver connectors, the small HF driver connector must be on the left, and the larger one on the right.
11. Secure the HF driver on the LF driver with the two screws.
Use the 3 mm hex bit. Set the torque to 3 N.m.

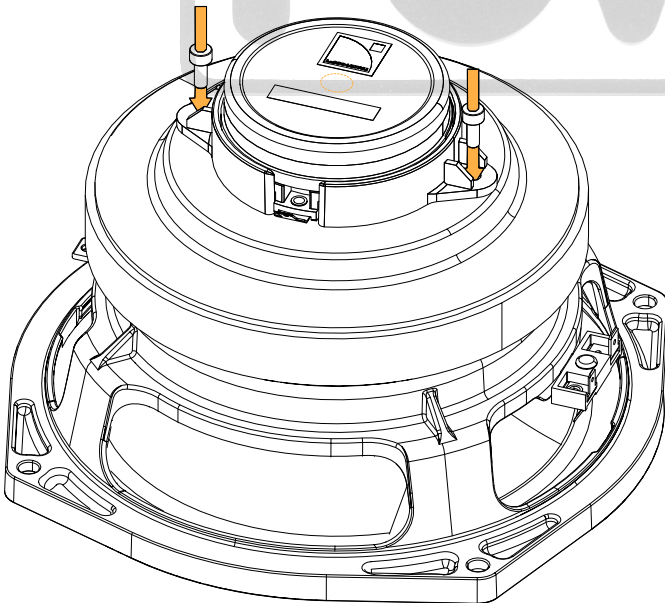

Acoustical check

Enclosure check



This feature is available on:

LA4X
LA12X

ENCLOSURE CHECK measures impedance at the reference frequencies for the connected loudspeaker family. The measured impedance is compared to the expected range allowing for fast detection of loudspeakers presenting circuit continuity issues.



The results can be used for preliminary diagnosis but cannot replace a comprehensive quality control.

Prerequisite



ENCLOSURE CHECK measurements can only be reliable if the following requirements are met:

Environment and temperature:

- Ambient temperature must be comprised between 0 °C / 32 °F and 40 °C / 104 °F. Ideal temperature is 20 °C / 68 °F.
- Enclosures must be at room temperature. If warm from a recent high level use or recently moved from a cold environment, let the loudspeakers reach room temperature before starting.

Enclosures:

- Enclosures must be included in the embedded factory preset library.
- Enclosures must be in nominal operating conditions:
 - Remove covers or dollies obstructing the loudspeakers or the vents.
 - Check for obvious physical damage or air leak: visually inspect the grill, gasket, cabinet, and connector plate for loose, missing or damaged parts.

Connection:

- Use only 10 m / 30 ft 4 mm² / AWG 11 speaker cables.
- Do not connect enclosures in parallel.

Amplified controllers:

- LA4X must run at least firmware version 1.1.0.
- LA4X load sensors must be calibrated. Refer to the **Load Sensor Calibration Tool** technical bulletin for more information.
- LA4X must warm up for at least 10 minutes after power up. Do not power off, reboot or switch to standby mode to avoid resetting the countdown.
- Load a preset corresponding to the connected loudspeaker's family. Presets from the user memories may be used on condition they are made of presets supported in the embedded factory preset library.

Procedure

1. Power up the amplified controller. Let LA4X warm up for at least 10 minutes.
2. Connect the loudspeaker enclosures to the amplified controller.
3. Load a preset from or built from the embedded library corresponding to the connected loudspeaker family.
4. On the amplified controller, use the encoder wheel to select **MONITORING & INFO**. Press the OK key or the encoder wheel to validate.
5. Use the encoder wheel to select **ENCLOSURE CHECK**.



Beware of sound levels.

Although the sound pressure levels generated for the ENCLOSURE CHECK are moderate, do not stay within close proximity of the loudspeakers and consider wearing ear protection.

6. Press the OK key or the encoder wheel to launch the ENCLOSURE CHECK.

The amplified controller generates short sinusoidal signals simultaneously for each connected output.

The amplified controller displays the results for each output.

7. Depending on the displayed results, follow the instructions in the table.

result	interpretation	instructions
OK	measured impedance is within expected range	enclosure is in working order electrically
?	unsupported preset family	only supported enclosures should be tested
NC	Not Connected	if cables are connected: a. inspect the cables and connections b. go to step 8 (p.186)
NOK	measured impedance is not within expected range	a. check that all the prerequisites are met, in particular that the loaded preset corresponds to the connected speaker's family b. inspect the cables and connections c. go to step 8 (p.186)
UNDEF	measured impedance is undefined	

8. Under NC, NOK and UNDEF results, press and hold the corresponding OUT key.

The amplified controller displays:

- the tested frequencies,
- information on the measured impedance:
 - OPEN for open circuit (found in NC results),
 - SHORT for short circuit (found in NOK results), or
 - a percentage of variation from the expected range (found in NOK and UNDEF results)
- the number of operational transducers out of the total

i Low variations from the expected range are acceptable: displayed percentage can be different from 0 and all transducers considered operational.

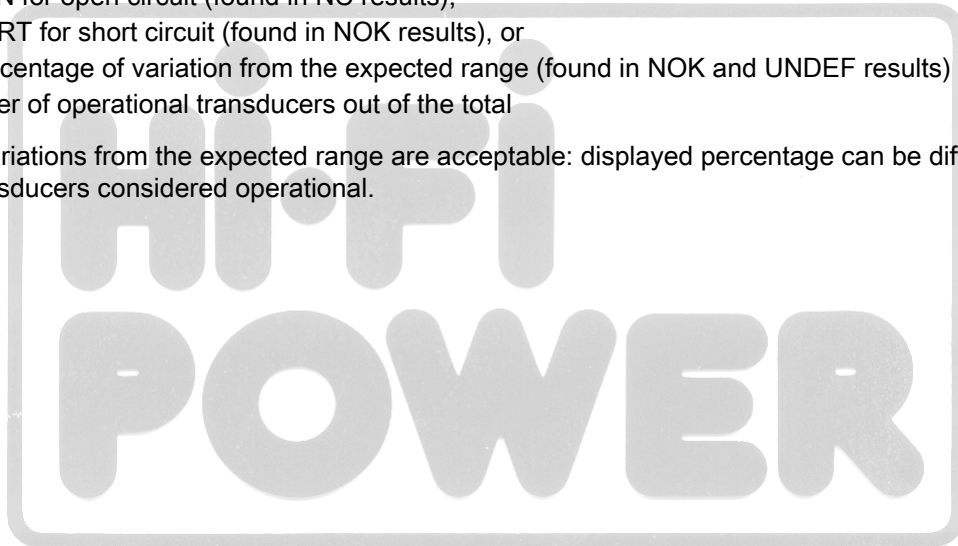

Listening test

Procedure

1. Load the preset on an LA2Xi / LA4X / LA7.16i / LA12X amplified controller.
2. Connect a sine wave generator to the amplified controller.



Risk of hearing damage

Set a low sound level to start and use ear protection to adjust before testing.

3. Scan the bandwidth focusing on the usable range.
The sound should remain pure and free of unwanted noise.
4. Focus on the 35 Hz frequency.
The sound should remain pure and free of unwanted noise.

Troubleshooting for installation enclosures

One or more enclosure produces a high-pitched, leaking air sound.

Possible cause

- Placeholder screws are missing.

Procedure

Visually inspect the screws on each side of the enclosures.

Secure placeholder screws in the empty inserts.

Troubleshooting for LF speakers

One or more LF speaker produces distorted, buzzing, rubbing, clicking, muffled or weak sound.

Possible causes

- The screws are not tightened with the appropriate torque.
- There is an air leak in the gasket.
- There is dust on the cone.
- The cone is damaged.
- The surround is torn or delaminated.
- The voice coil or the spider is damaged.

Procedure

1. Perform the speaker disassembly procedure.
2. Visually inspect the cables and the connectors.
3. Visually inspect the speaker cone, the voice coil and the spider.

If any damage is visible, replace the speaker.

4. Carefully clean the speaker with a dry cloth.
5. Perform the reassembly procedure.
Replace the speaker gasket and the screws.
Apply the recommended torque.

6. Repeat the listening test.

If the problem persists, replace the speaker.

Troubleshooting for HF drivers

One or more HF driver produces high-frequency harmonic distortions, strange vibrations or weak sound.

Possible causes

- There are foreign particles on the air gap.
- The diaphragm is not centered correctly.
- The screws used for reassembly are too loose.

- The diaphragm is damaged.

Procedure

1. Perform the diaphragm disassembly procedure.
2. Visually inspect the diaphragm and the voice coil.
If any damage is visible, replace the diaphragm.
3. Clean the air gap thoroughly.
Use double-face adhesive tape to remove any particles.
4. Perform the diaphragm reassembly procedure.
Apply the recommended torque.
5. Repeat the listening test.
If the problem persists, replace the driver.

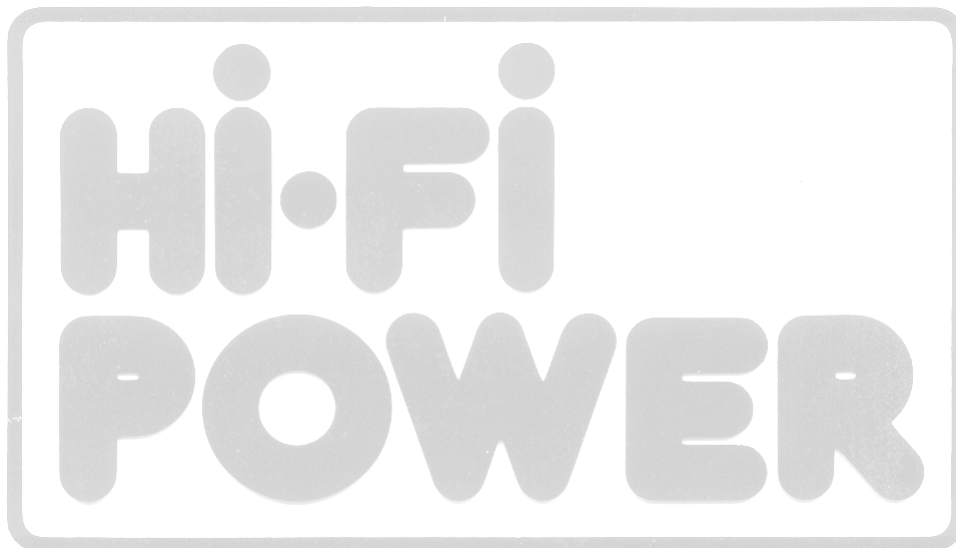

Specifications

X8i specifications

Description	2-way passive coaxial enclosure: 8" LF + 1.5" HF diaphragm (installation version) amplified by LA2Xi / LA4X / LA7.16i / LA12X	
	with [X8i_40]	with [X8i]
Usable bandwidth (-10 dB)	43 Hz - 20 kHz	67 Hz - 20 kHz
Maximum SPL¹	with LA2Xi (bridge mode) / LA4X / LA7.16i / LA12X	123 dB
	with LA2Xi (single-ended mode)	121 dB
Nominal directivity (-6 dB)	90° axisymmetric	
Monitoring angle	35° / 55°	
Transducers	LF: 1 × 8" HF: 1 × 1.5" neodymium	
Acoustical load	bass-reflex	
Nominal impedance	8 Ω	
Connectors	1 × 4-point terminal block with push-in connection	
Rigging and handling	8 M6 inserts	
Weight (net)	11 kg / 24 lb	
Cabinet	premium grade Baltic beech and birch plywood	
Front	coated steel grill acoustically neutral 3D fabric	
Finish	dark grey brown Pantone 426 C pure white RAL 9010 custom RAL code on special order	
IP	IP55 ²	

¹ Peak level measured at 1 m under free field conditions using pink noise with crest factor 4 (preset specified in brackets).

² With connector at the top and connector sealing plate.

X8i dimensions

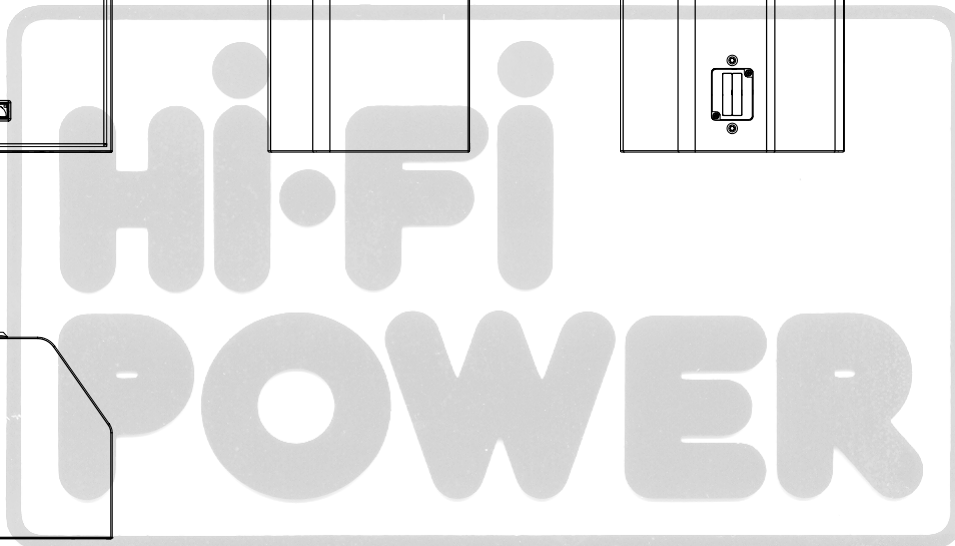
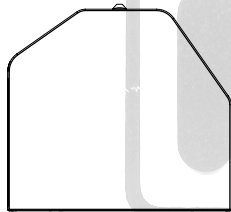
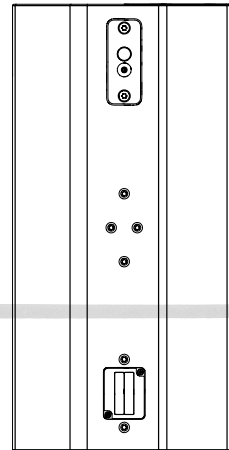
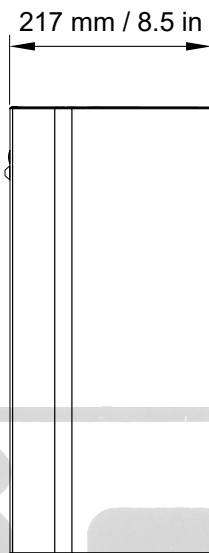
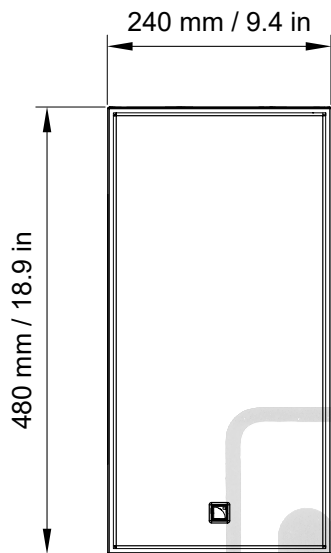
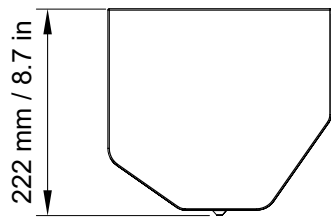

X8i-onCW specifications

Description	On-wall or on-ceiling mounting accessory with silent blocks for X8i
Weight (net)	0.8 kg / 1.8 lb
Material	steel with anti-corrosion coating

X8i-onCW dimensions

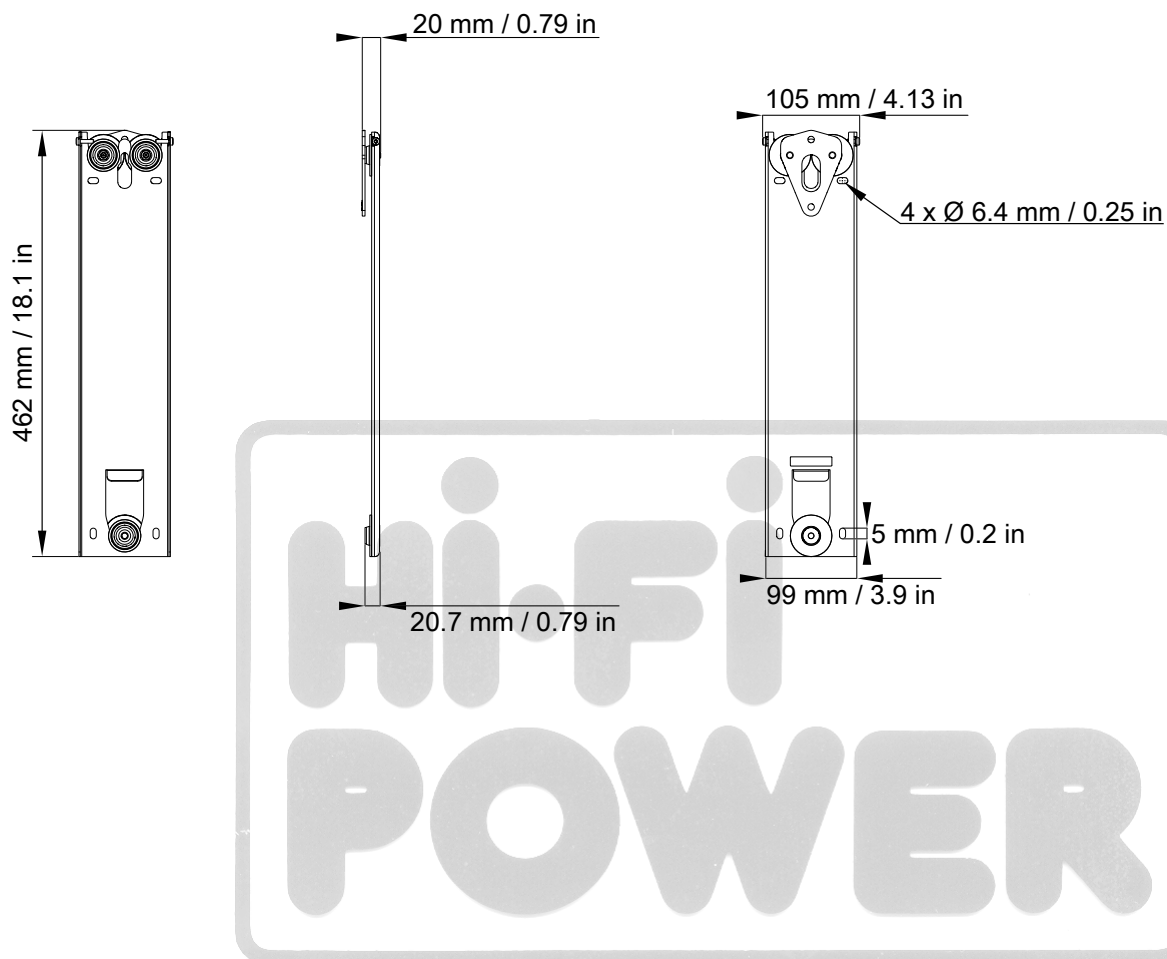

WALL specifications

Description	Wall-mounting accessory
Weight (net)	0.2 kg / 0.4 lb
Material	steel with anti-corrosion coating

WALL dimensions

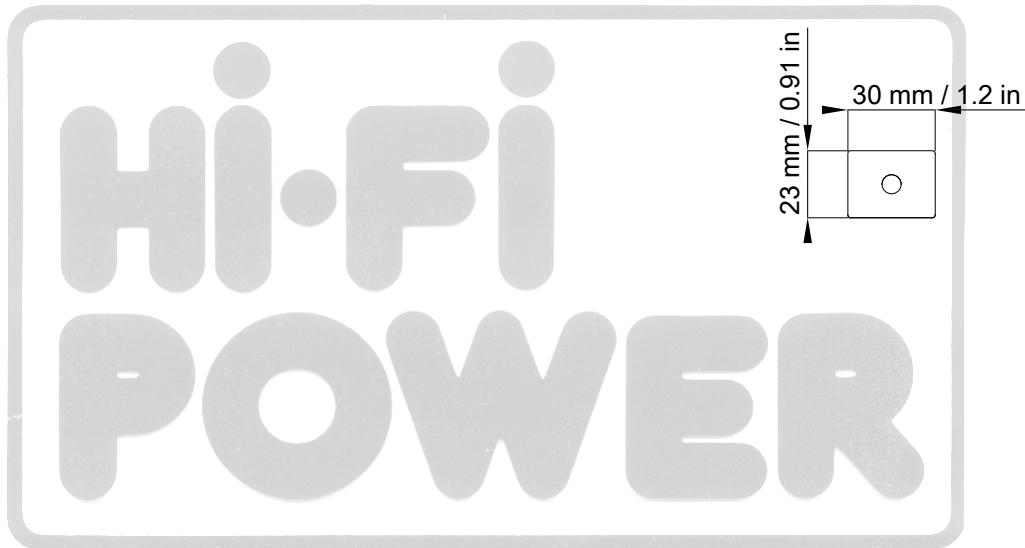
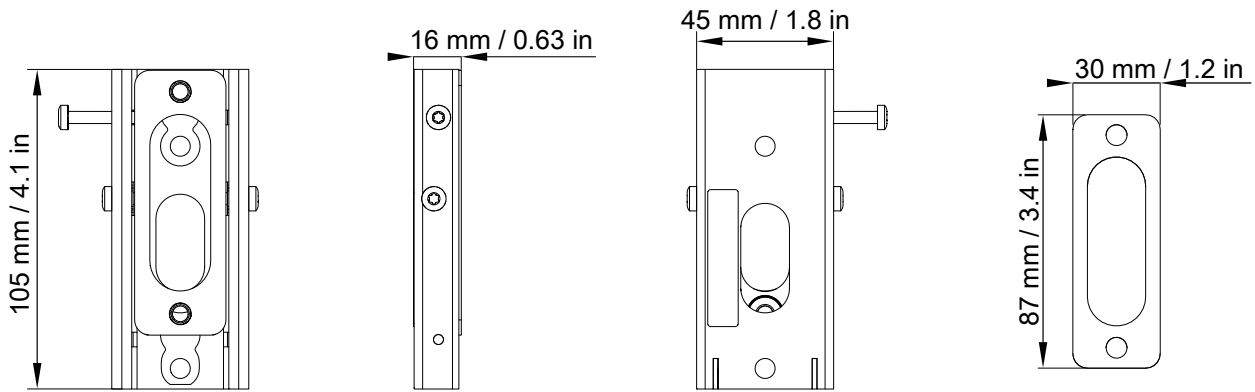

PAN specifications

Description	Adjustable pan accessory +/-45°
Weight (net)	0.4 kg / 0.9 lb
Material	steel with anti-corrosion coating

PAN dimensions

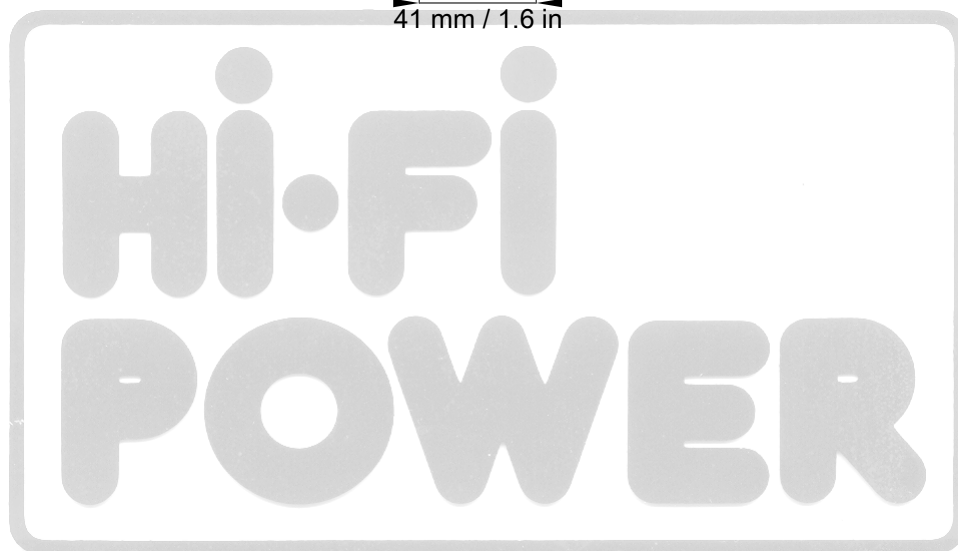
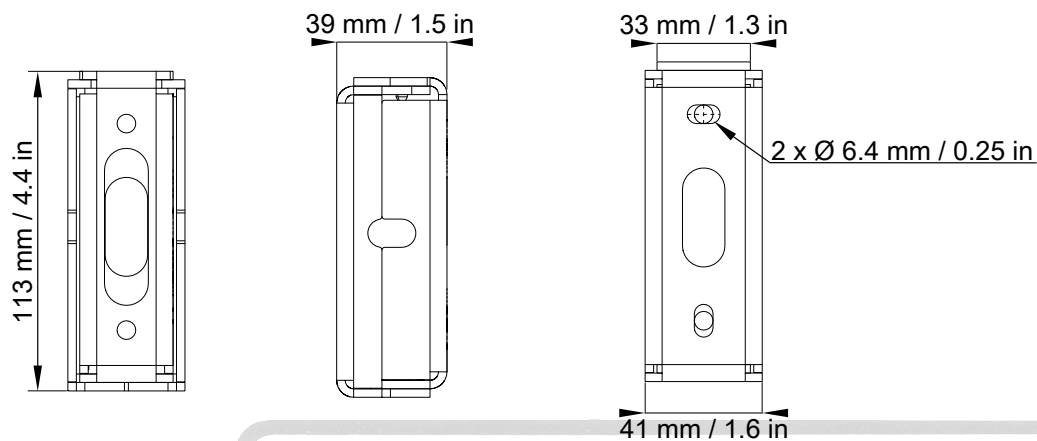

WALLx2 specifications

Description	Wall-mounting kit
Weight (net)	0.4 kg / 0.9 lb
Material	steel with anti-corrosion coating

WALLx2 dimensions

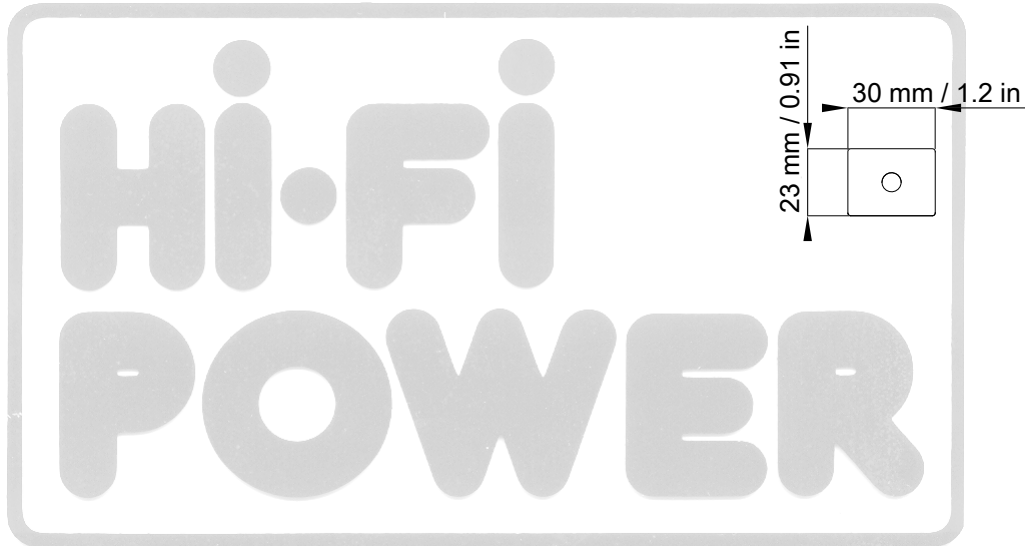
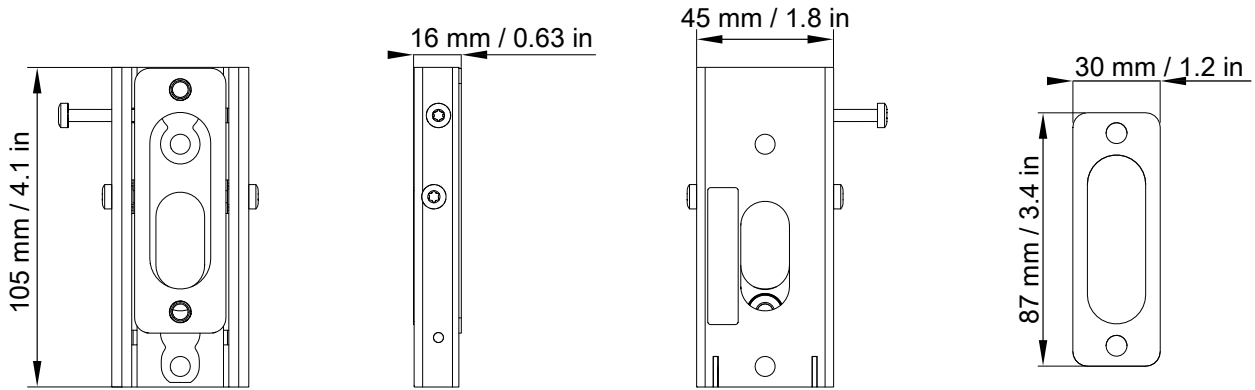

PANx2 specifications

Description	Adjustable pan accessory kit +/-45°
Weight (net)	0.8 kg / 1.8 lb
Material	steel with anti-corrosion coating

PANx2 dimensions

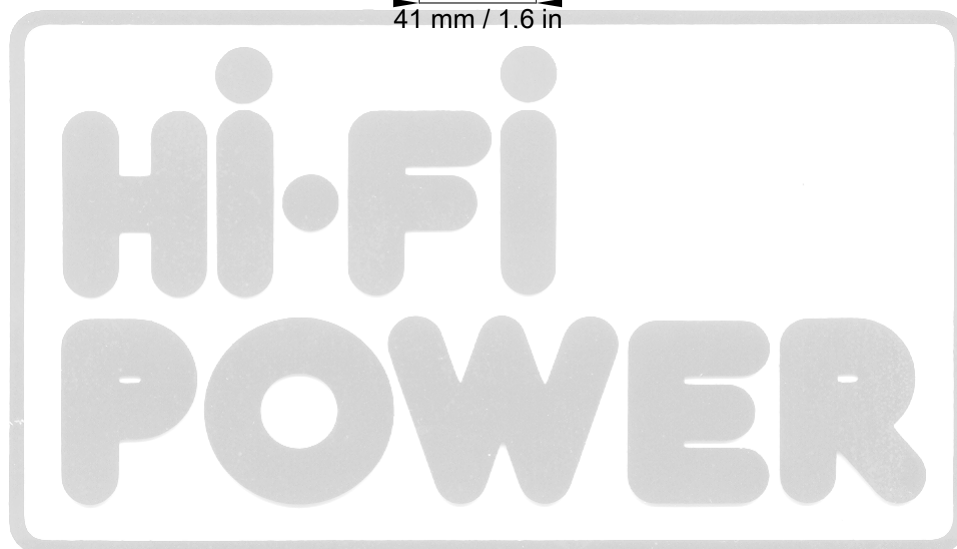
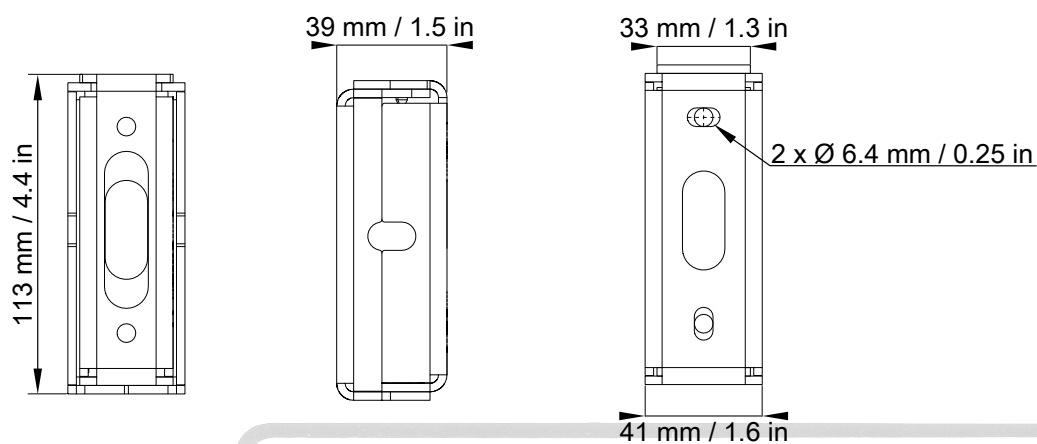

TILT specifications

Description	Adjustable tilt accessory from 0° to 40°
Weight (net)	0.6 kg / 1.3 lb
Material	steel with anti-corrosion coating

TILT dimensions

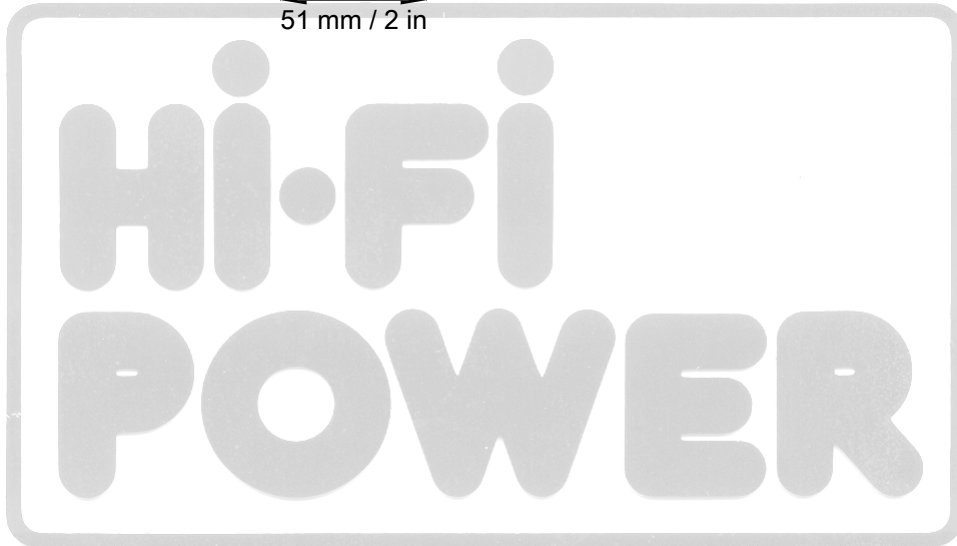
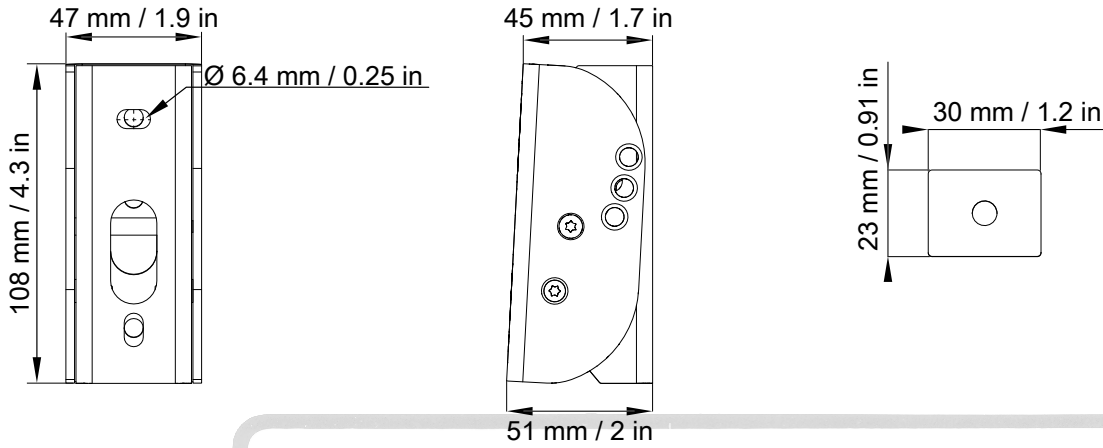

TILT5 specifications

Description	Fixed tilt accessory 5°
Weight (net)	0.3 kg / 0.7 lb
Material	steel with anti-corrosion coating

TILT5 dimensions

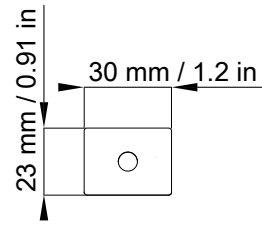
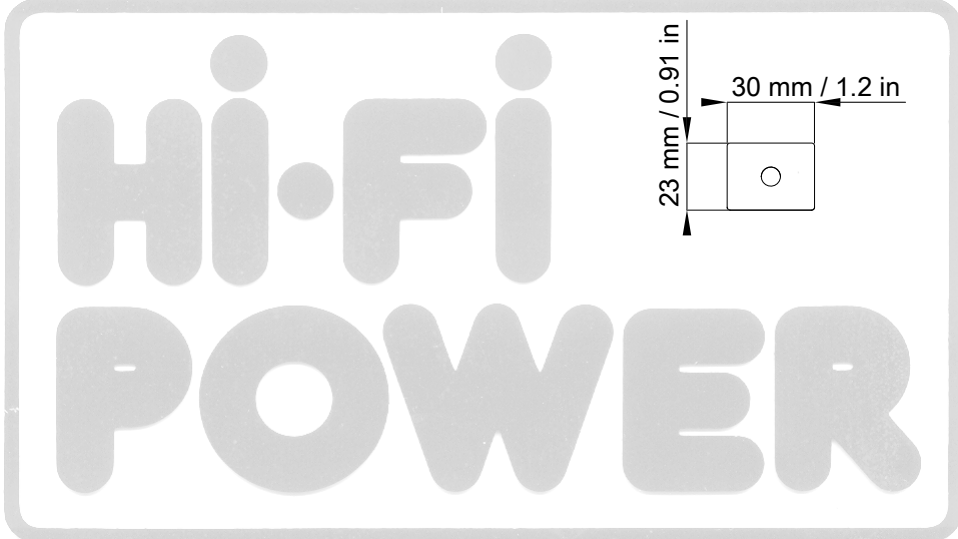
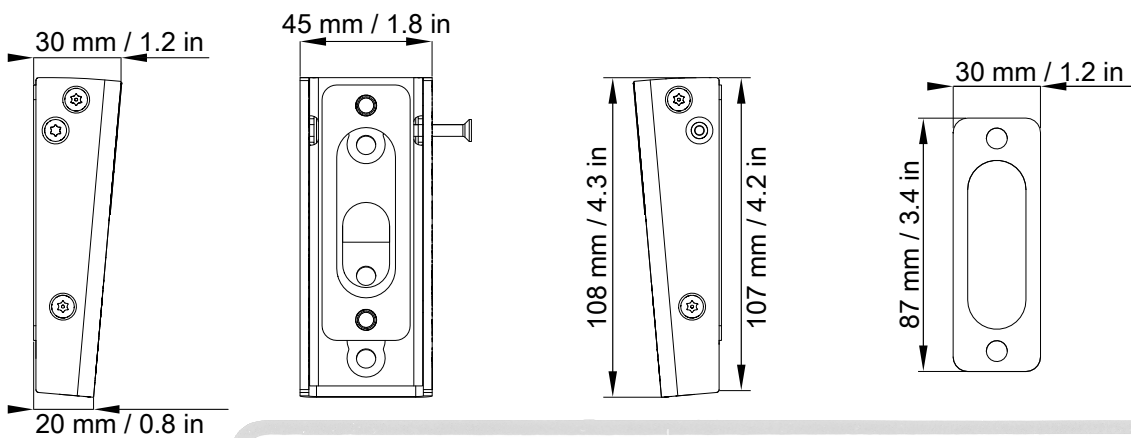

TILT15 specifications

Description	Fixed tilt accessory 15°
Weight (net)	0.4 kg / 0.9 lb
Material	steel with anti-corrosion coating

TILT15 dimensions

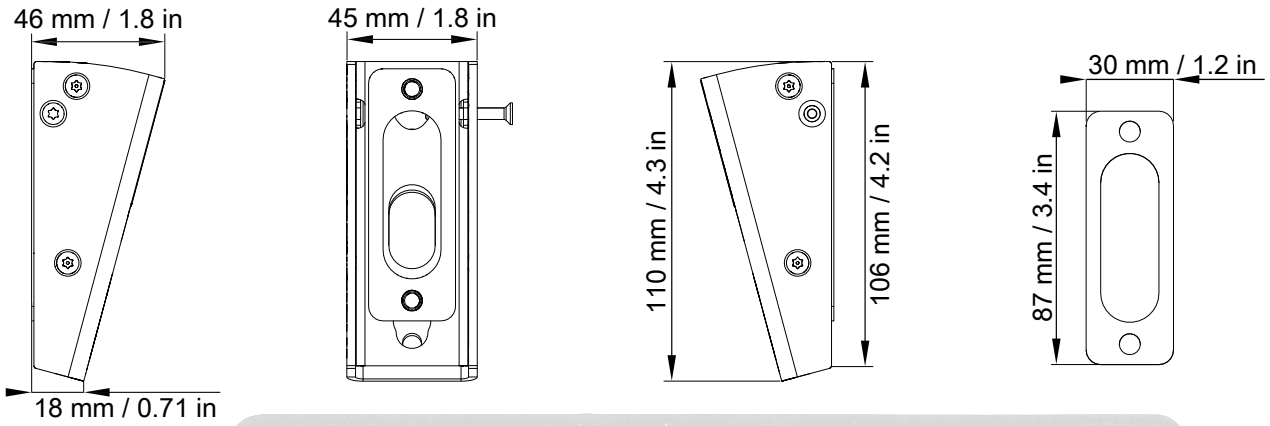

TILT40 specifications

Description	Fixed tilt accessory 40°
Weight (net)	0.5 kg / 1.1 lb
Material	steel with anti-corrosion coating

TILT40 dimensions

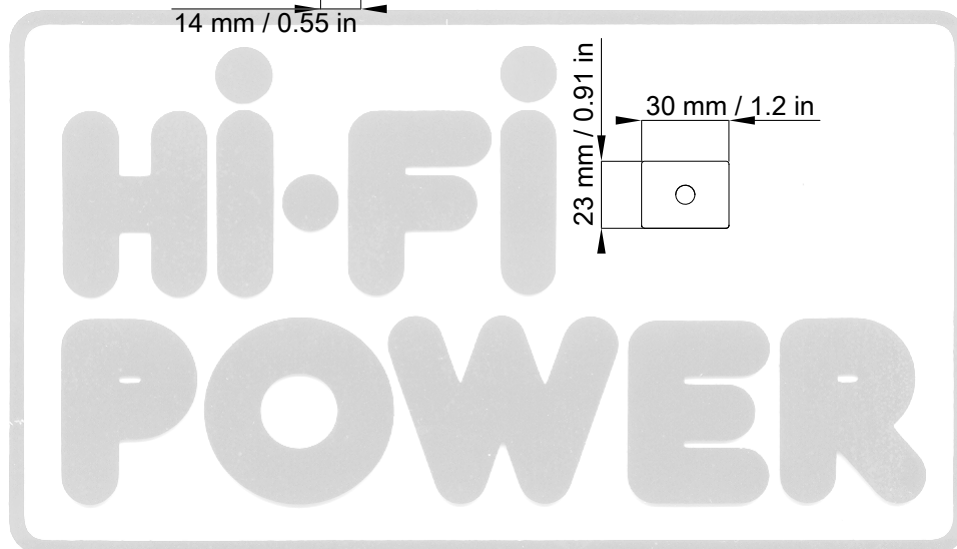
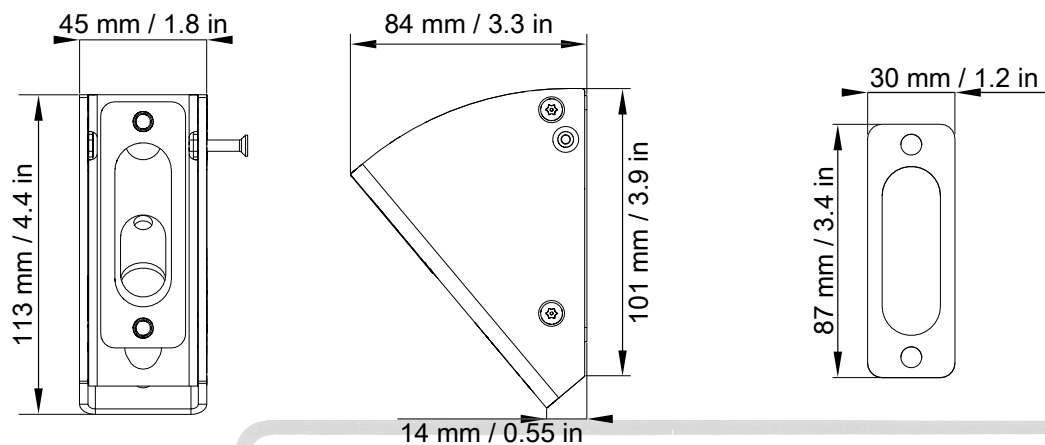

GROUND specifications

Description	Ground-mounting accessory
Weight (net)	0.2 kg / 0.4 lb
Material	steel with anti-corrosion coating

GROUND dimensions

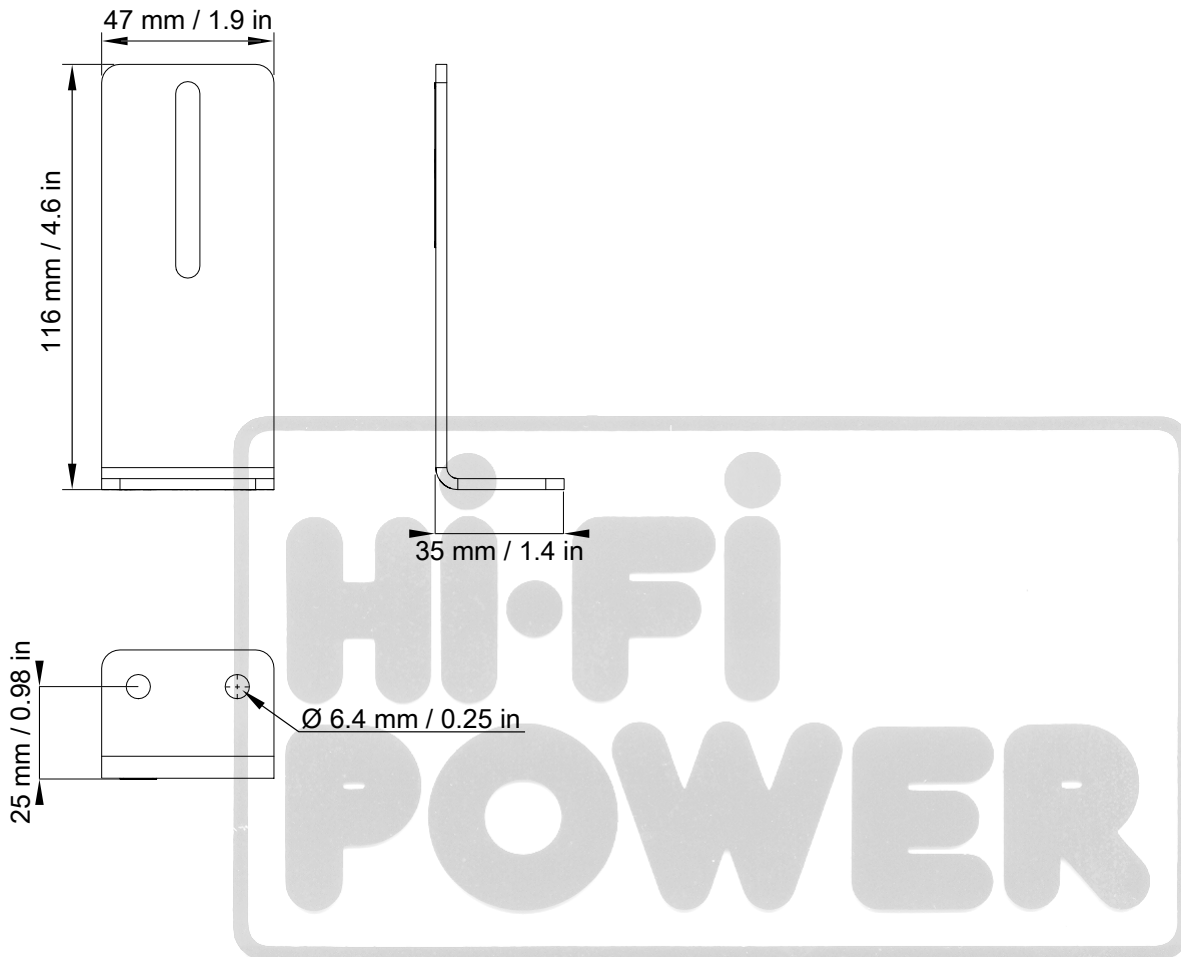

GROUND55 specifications

Description	Ground-mounting accessory for 55° site angle
Weight (net)	0.1 kg / 0.2 lb
Material	steel with anti-corrosion coating

GROUND55 dimensions

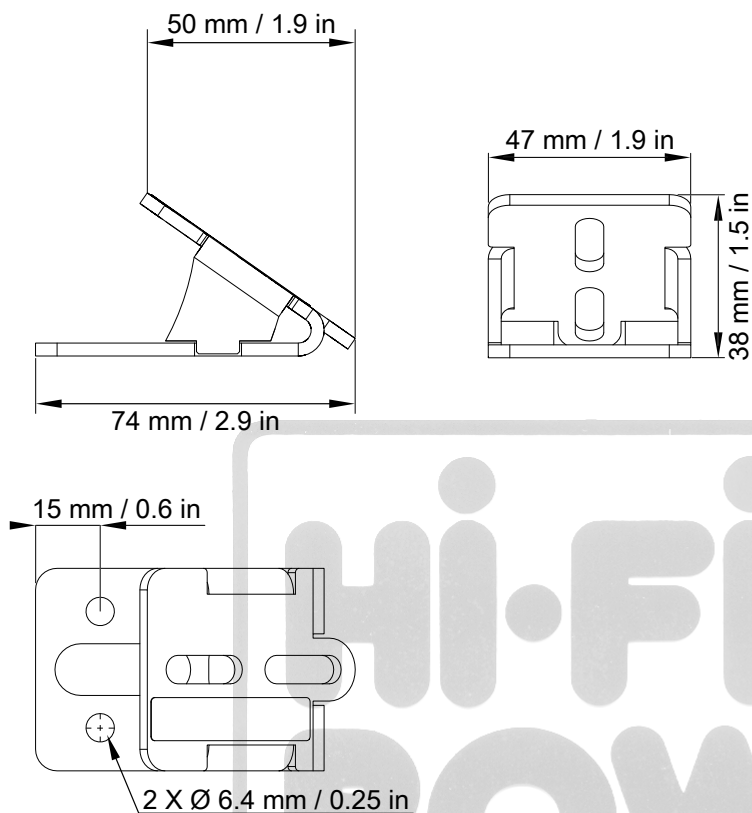

Hi-Fi
POWER

GROUND35 specifications

Description	Ground-mounting accessory for 35° site angle
Weight (net)	0.2 kg / 0.4 lb
Material	steel with anti-corrosion coating

GROUND35 dimensions

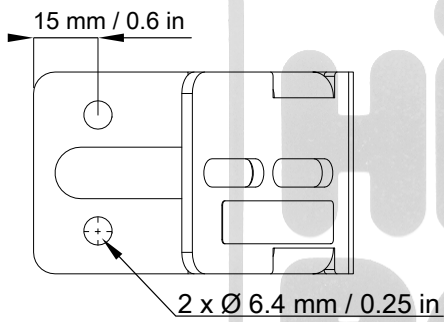
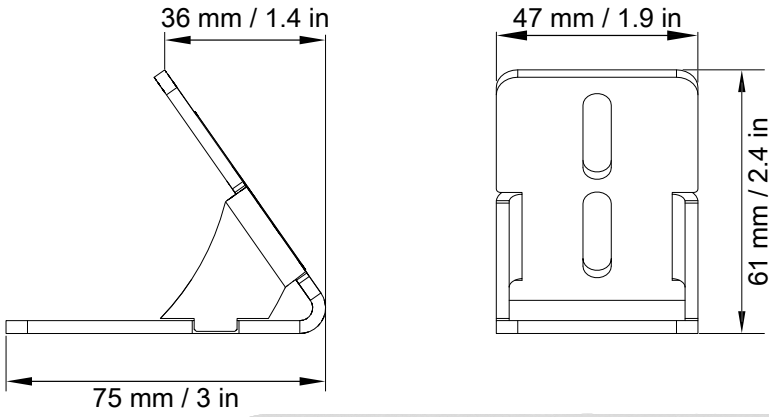

TILT-SUPPORT specifications

Description	Support plate for TILT/PAN/WALL accessories
Weight (net)	0.5 kg / 1.1 lb
Material	steel with anti-corrosion coating

TILT-SUPPORT dimensions

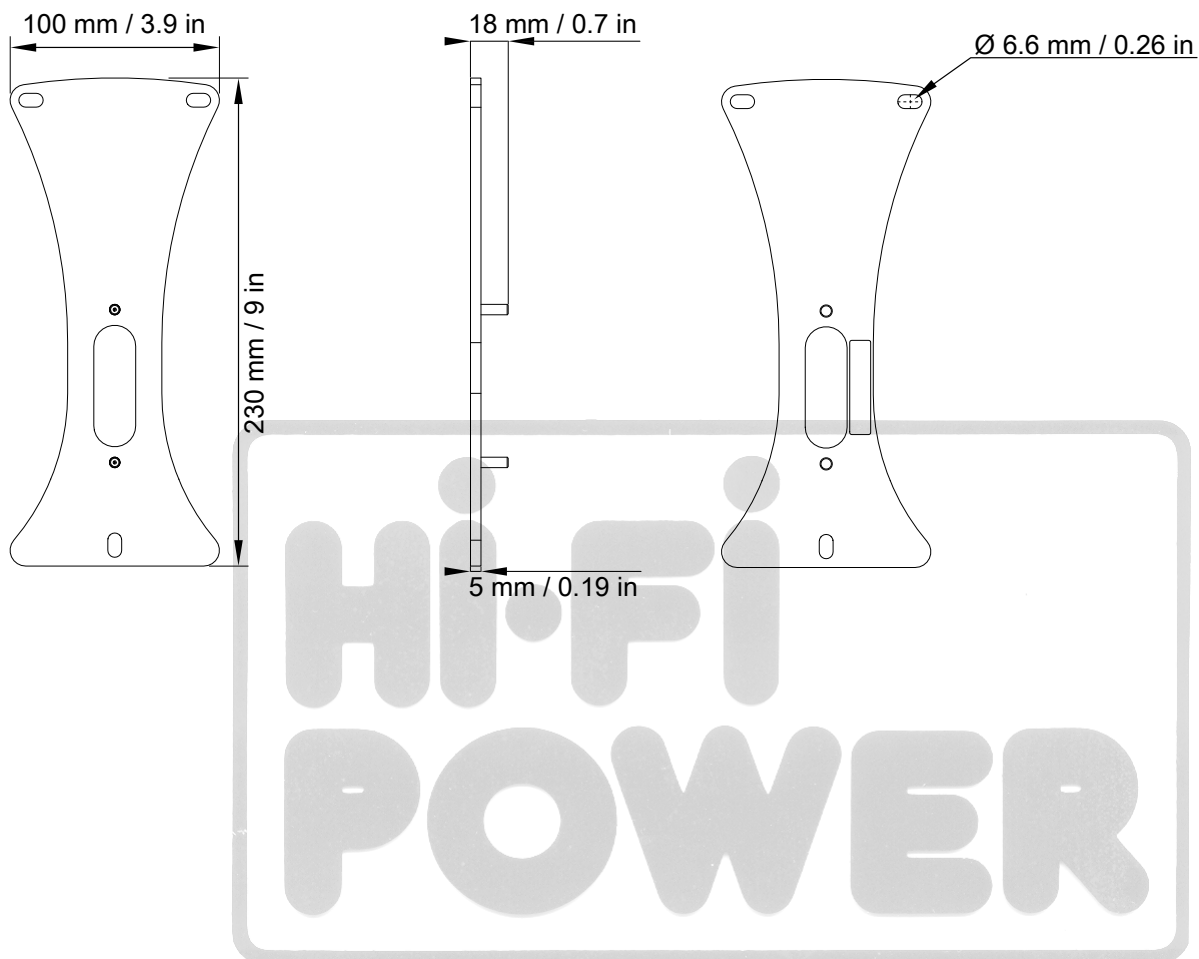

X8i-HBAR specifications

Description	Rigging accessory for horizontally-oriented X8i
Weight (net)	0.5 kg / 1.1 lb
Material	steel with anti-corrosion coating

X8i-HBAR dimensions

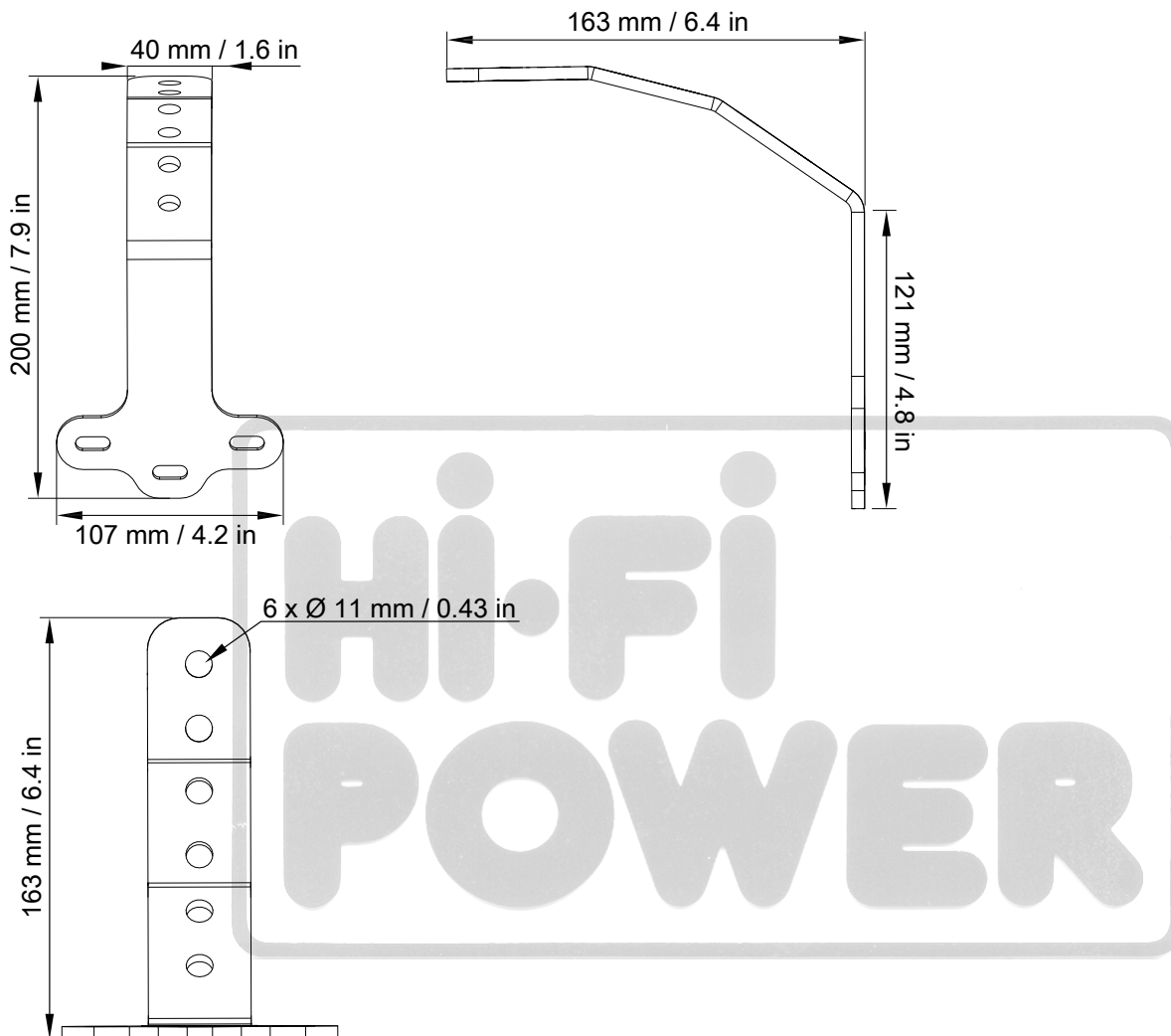

Hi-Fi
POWER

VBAR specifications

Description	Rigging accessory for vertically-oriented loudspeaker
Weight (net)	0.6 kg / 1.3 lb
Material	steel with anti-corrosion coating

VBAR dimensions

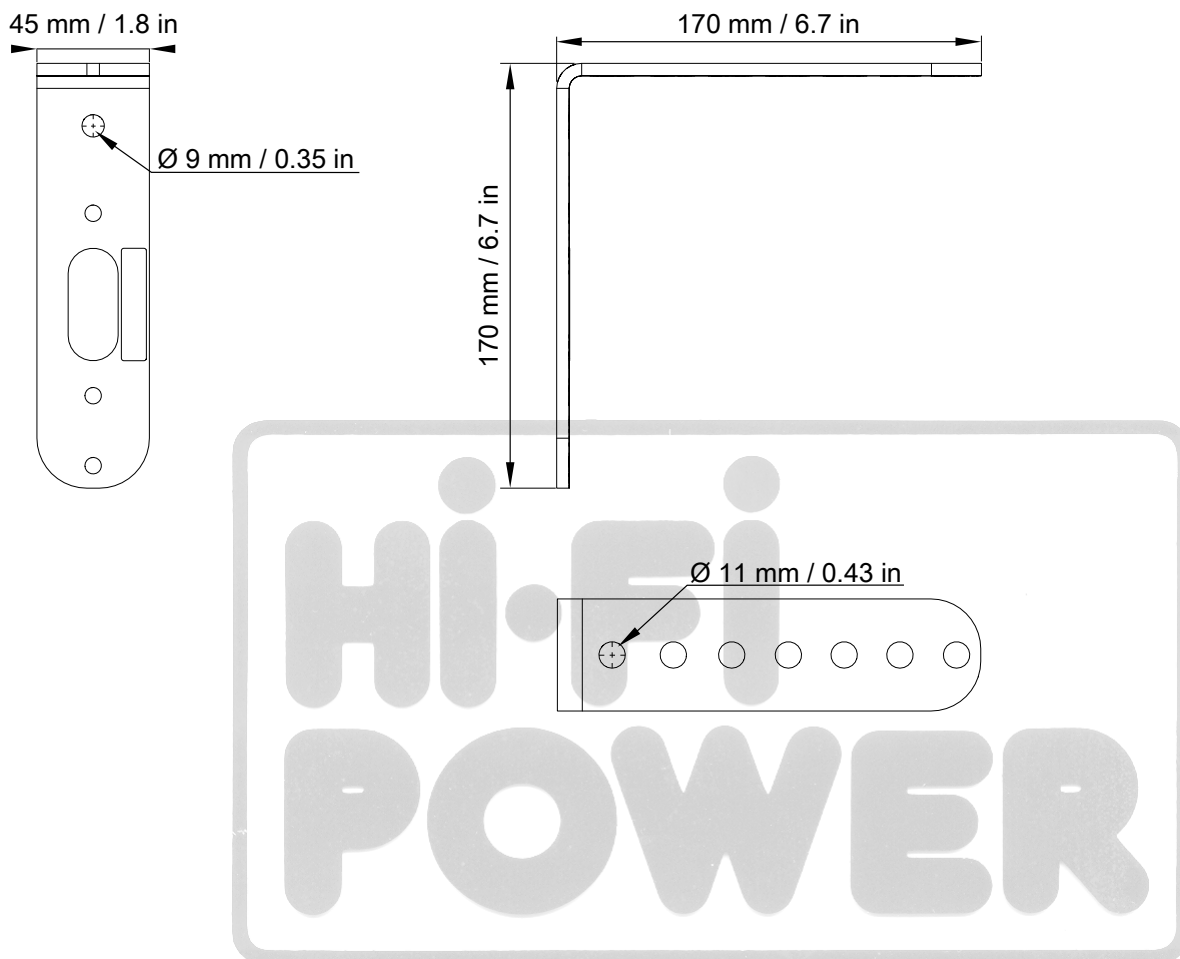

CEILING-PENDANT specifications

Description	Rigging accessory for ceiling-hung pendant loudspeaker
Weight (net)	0.1 kg / 0.2 lb
Material	steel with anti-corrosion coating

CEILING-PENDANT dimensions

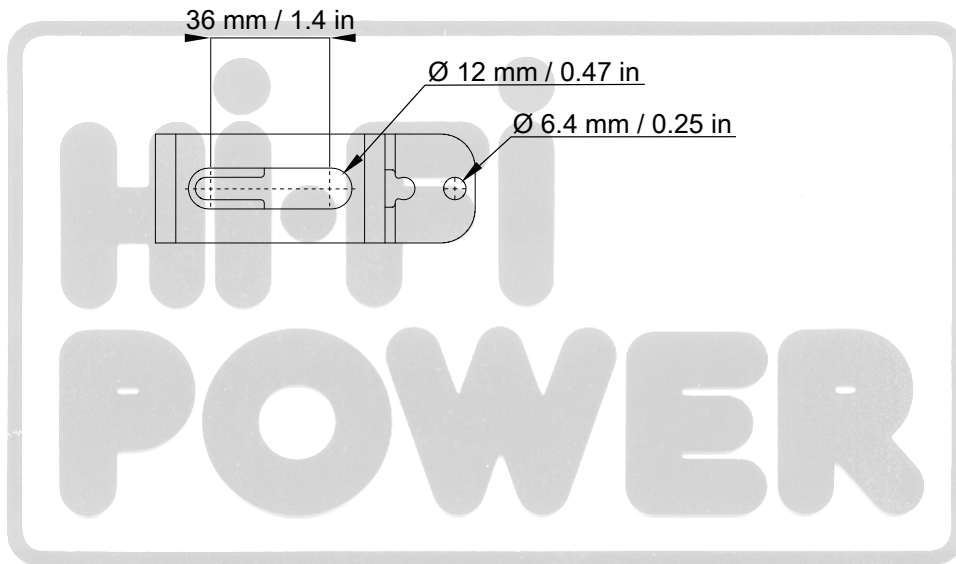
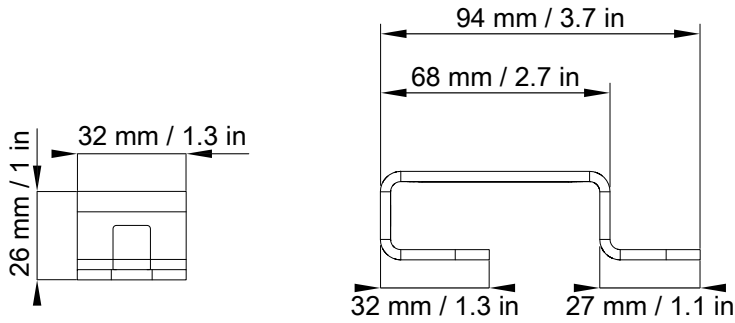

POLE specifications

Description	Pole-mount adapter
Weight (net)	0.5 kg / 1.1 lb
Material	steel with anti-corrosion coating

POLE dimensions

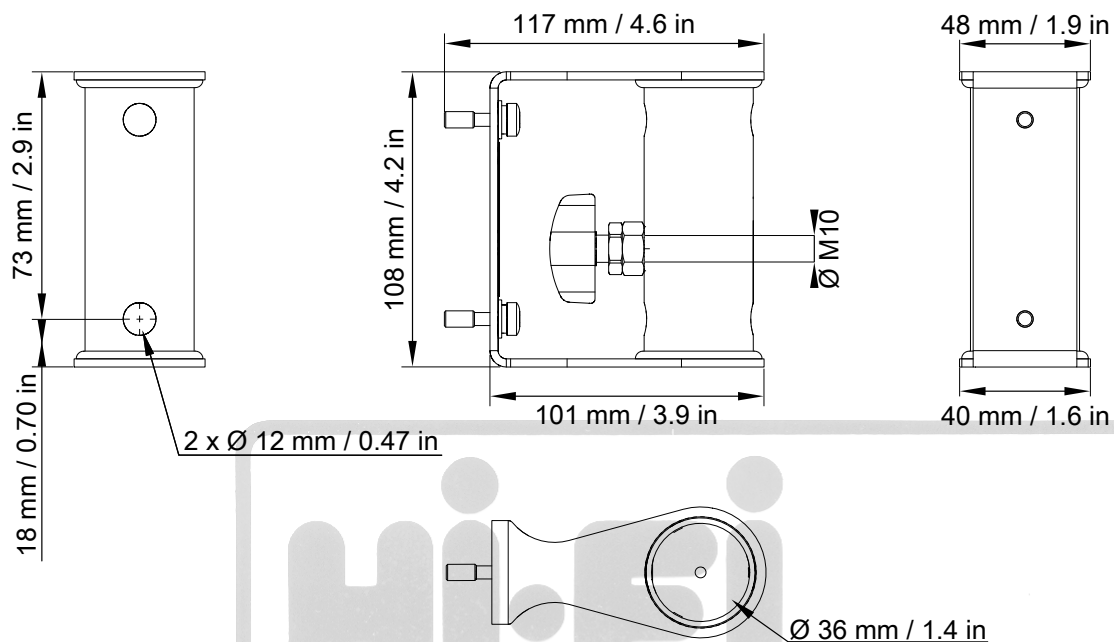

Hi-Fi
POWER

SPCON specifications

Description	2-point speakON adaptor (2.5 mm ² gauge) for terminal blocks
Weight (net)	0.1 kg / 0.2 lb
Material	moulded ABS polymer

SPCON dimensions

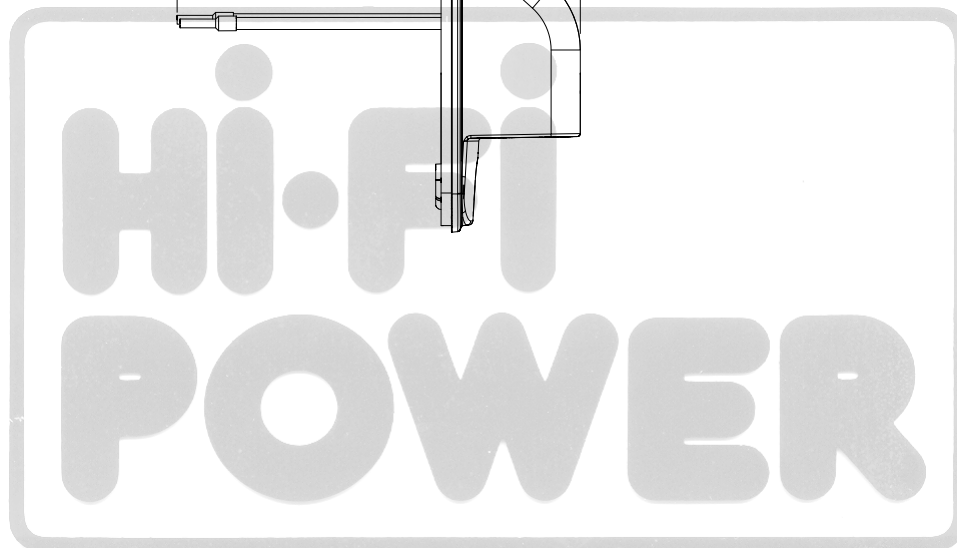
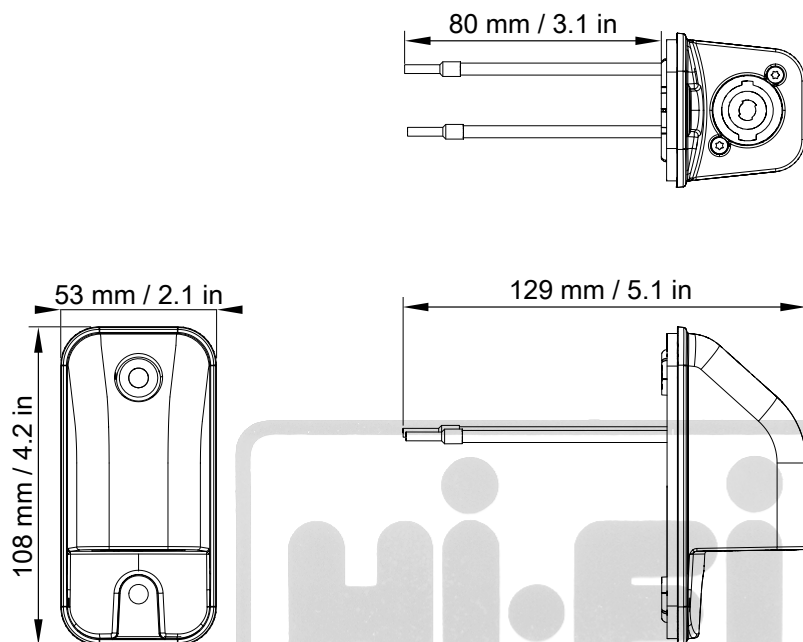

Specifications for screws and anchors

Use the following information to choose compatible screws and anchors for mounting X8i on the wall, on the ceiling, or on the ground.



Risk of crushing injury

Ensure that the wall or ceiling can support the load of the product.

It is recommended to mount only on solid structures. If mounting on a hollow structure (such as a wall cavity), place anchoring points on the framework (wall studs, ceiling joists), or reinforce the mounting area.

Select screws and anchors applicable to the wall or ceiling properties and to the load of the product. Prevent screws from loosening over time, using for example thread locker or lock washers.

deployment	accessory	ultimate tensile load per screw (daN)	ultimate shear load per screw (daN)	screws quantity	mounting hole size	specific constraints
wall-mounting	TILT-SUPPORT + any accessory	12	9	3	Ø 6.4 mm / 0.25 in (slotted)	–
wall-mounting	X8i-onCW	6	5	4	Ø 6.4 mm / 0.25 in (slotted)	total thickness with spacers: 13.10 mm / 0.51 in
wall-mounting	WALLx2	6	5	4	Ø 5.2 mm / 0.20 in	maximum screw head size: Ø 11 mm / 0.43 in
wall-mounting	PANx2	6	5	4	Ø 6.4 mm / 0.25 in (slotted)	–
ceiling-mounting	X8i-onCW	6	–	4	Ø 6.4 mm / 0.25 in	total thickness with washers: 13.10 mm / 0.51 in
ceiling-mounting	VBAR + optional TILT or TILTxx	19	–	2	Ø 10.4 mm / 0.41 in	use the holes 1 and 7 (at both ends)
ceiling-mounting	X8i-HBAR	19	–	2	Ø 10.3 mm / 0.40 in	use two adjacent, coplanar holes distance between centers: 25 mm / 0.98 in
ground-mounting	GROUND / GROUND35 / GROUND55	–	–	2	Ø 6.4 mm / 0.25 in	–

Recommendation for speaker cables



Cable quality and resistance

Only use high-quality fully insulated loudspeaker cables made of stranded copper wire.

Use cables with a gauge offering low resistance per unit length and keep the cables as short as possible.

It is good practice to keep loudspeaker cables short to ensure optimal system performance. L-Acoustics strongly recommends using cables of similar type, length, and gauge to address symmetrical deployment of loudspeakers, such as stereo systems, L-ISA frontal systems, or outfill systems.



For more information about cable effect on loudspeaker frequency response, refer to the publication **Demystifying the effects of loudspeaker cables** on the L-Acoustics website, in **Education > Scientific resources > Scientific publications**.

Refer to the following table for recommended cable length for uncompromised performance.

cable gauge			recommended maximum length					
			8 Ω load		4 Ω load		2.7 Ω load	
mm ²	SWG	AWG	m	ft	m	ft	m	ft
1.5	18	16	18	60	9	30	–	–
2.5	15	14	30	100	15	50	10	33
4	13	11	50	160	25	80	17	53
6	11	9	74	240	37	120	25	80

Use the more detailed L-Acoustics calculation tool to evaluate cable length and gauge based on the type and number of loudspeakers connected. The calculation tool is available on our website:

<https://www.l-acoustics.com/installation-tools/>

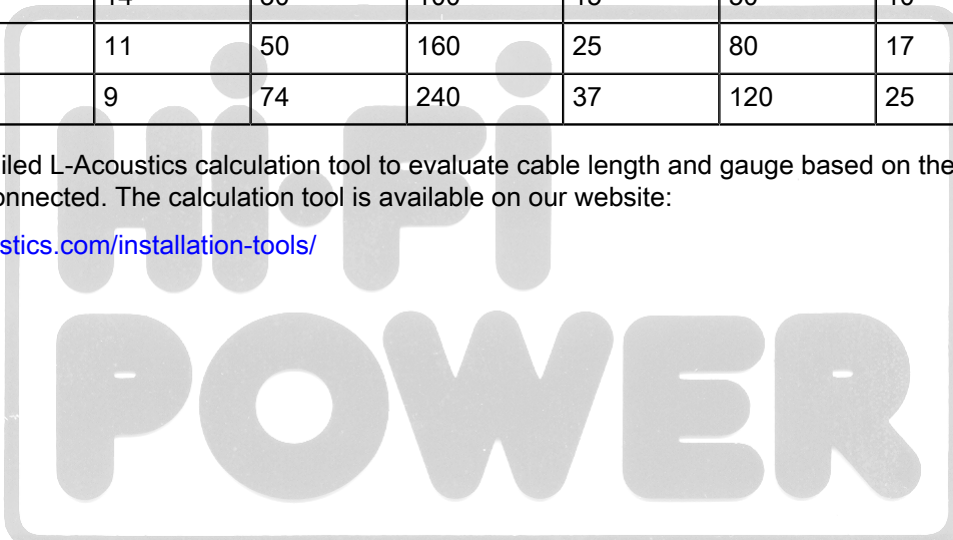

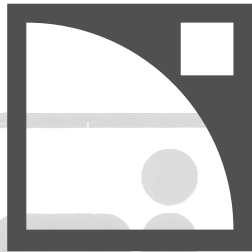

L-ACOUSTICS

L-Acoustics

13 rue Levacher Cintrat - 91460 Marcoussis - France

+33 1 69 63 69 63 - info@l-acoustics.com

www.l-acoustics.com

Hi-Fi
POWER

 **L-ACOUSTICS**
GROUP

**Hi-Fi
POWER**

HOME &
PROFESSIONAL
AUDIOVISUAL

• MAPNH 8 ΑΘΗΝΑ 10433 • ΤΗΛ. 210 3845676 – 210 3845272 FAX. 210 3809747 • e-mail: sales@hifipower.gr •