

X12

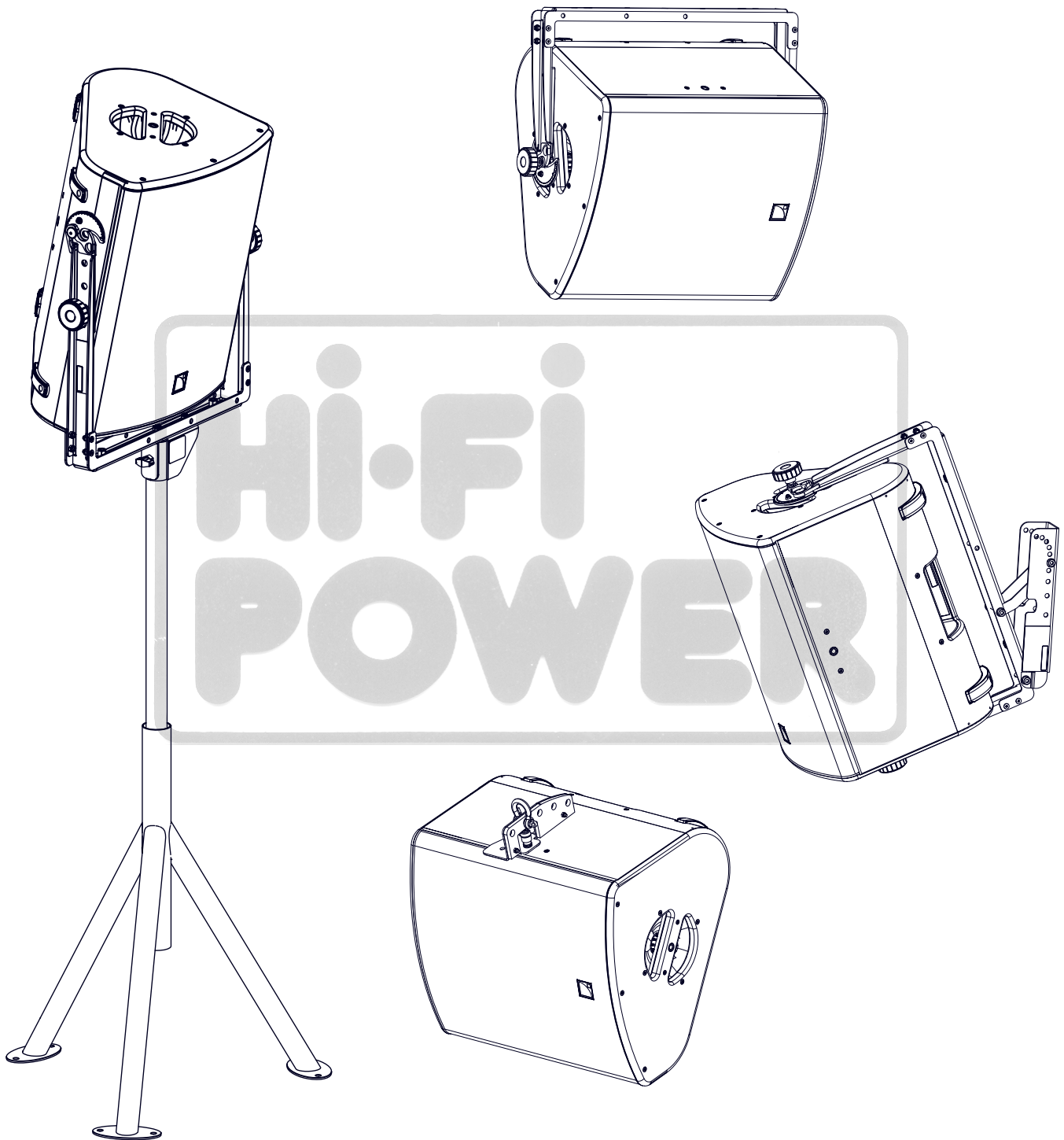

owner's manual (EN)

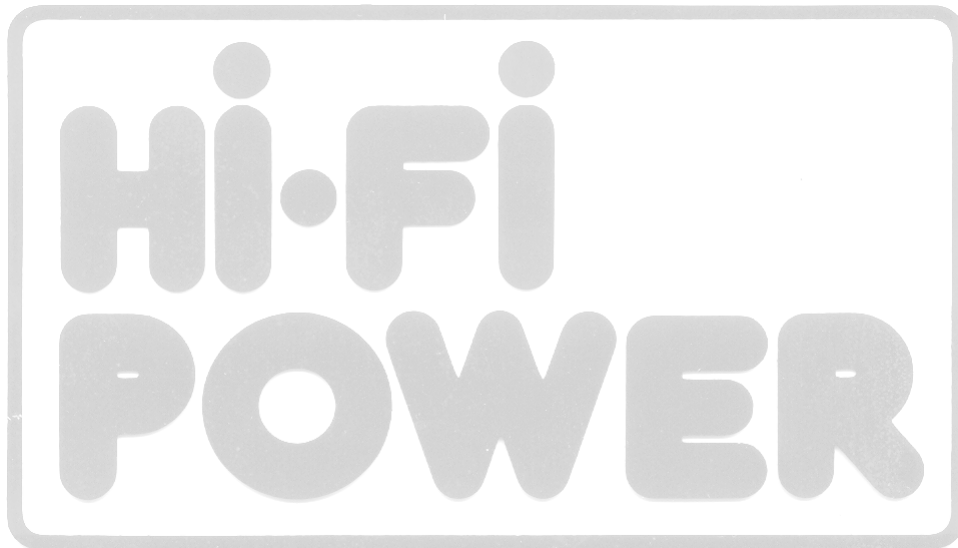



Document reference: X12 owner's manual (EN) version 2.0

Distribution date: December 7, 2021

© 2021 L-Acoustics. All rights reserved.

No part of this publication may be reproduced or transmitted in any form or by any means without the express written consent of the publisher.

Contents

Safety.....	5
Instructions.....	5
Introduction.....	7
X12 multi-purpose enclosure.....	7
How to use this manual.....	7
Revision history.....	8
System components.....	8
Electro-acoustical description.....	11
Directivity.....	11
Monitor angles.....	12
Preset description.....	12
Connectors.....	13
Rigging system description.....	14
X12.....	14
Elements for flying and wall-mounting.....	16
X-US1215 and X-UL12.....	16
X-UTILT.....	18
X-BAR.....	20
Elements for pole-mounting.....	21
Pole sockets.....	21
EMBi.....	22
Subwoofers.....	23
Mechanical safety.....	24
Loudspeaker configurations.....	25
X12 point source.....	25
X12 point source with LF.....	26
X12 with SB15m.....	26
X12 with SB18.....	27
X12 with KS21.....	28
X12 stage monitor.....	30
Low-latency preset.....	30
Paired X12 monitors with LFC.....	30
X12 stage monitor with LF.....	31
X12 with SB15m.....	31

X12 with SB18.....	32
X12 with KS21.....	33
Inspection and preventive maintenance.....	34
How to do preventive maintenance.....	34
Rigging part inspection.....	34
Mechanical system overview.....	35
Inspection references.....	40
Acoustical check.....	42
Rigging procedures.....	46
Wall-mounting and ceiling-mounting.....	46
Mounting on X-US1215 or X-UL12.....	46
Using X-US1215 or X-UL12 with X-UTILT.....	50
Flying.....	57
Flying with X-US1215 or X-UL12.....	57
Flying with X-BAR.....	63
Pole-mounting.....	67
Pole-mounting with X-US1215.....	67
Connection to LA amplified controllers.....	73
Corrective maintenance.....	74
Introduction.....	74
X12.....	75
Specifications.....	80
X12.....	80
SB18.....	84
SB18 Ili.....	86
KS21.....	88
KS21i.....	90
X-UL12.....	92
X-US1215.....	93
X-BAR.....	94
X-UTILT.....	95
EMBi.....	96
APPENDIX: Recommendation for speaker cables.....	97

Safety

Instructions

- ! Inspect the system before any deployment.**
Perform safety related checks and inspections before any deployment.
- Perform preventive maintenance at least once a year.**
Refer to the preventive maintenance section for a list of actions and their periodicity.
Insufficient upkeep of the product can void the warranty.
- If any safety issue is detected during inspection, do not use the product before performing corrective maintenance.**
Check for issues. A rigging system part or fastener is missing or loose. A rigging system part exhibits: bends, breaks, broken parts, corrosion, cracks, cracks in welded joints, deformation, denting, wear, holes. A safety cue or label is missing.
- ! Never incorporate equipment or accessories not approved by L-Acoustics.**
- ! Read all the related PRODUCT INFORMATION documents shipped with the products before exploiting the system.**
- ! Do not store the product on an unstable cart, stand, tripod, bracket, or table.**
- ! Beware of sound levels.**
Do not stay within close proximity of loudspeakers in operation.
Loudspeaker systems are capable of producing very high sound pressure levels (SPL) which can instantaneously lead to permanent hearing damage to performers, production crew and audience members. Hearing damage can also occur at moderate level with prolonged exposure to sound.
Check the applicable laws and regulations relating to maximum sound levels and exposure times.
- ! Work with qualified personnel for rigging the system**
Installation should only be carried out by qualified personnel that are familiar with the rigging techniques and safety recommendations outlined in this manual.
- Ensure personnel health and safety**
During installation and set-up personnel must wear protective headgear and footwear at all times. Under no circumstances is personnel allowed to climb on a loudspeaker assembly.
- Respect the Working Load Limit (WLL) of third party equipment.**
L-Acoustics is not responsible for any rigging equipment and accessories provided by third party manufacturers. Verify that the Working Load Limit (WLL) of the suspension points, chain hoists and all additional hardware rigging accessories is respected.
- Respect the maximum configurations and the recommended safety precautions.**
For safety issue, respect the maximum configurations outlined in this manual. To check the conformity of any configuration in regards with the safety precautions recommended by L-Acoustics, model the system in Soundvision and refer to the warnings in Mechanical Data section.
- Be cautious when flying a loudspeaker configuration.**
Before installing/raising the product, check each individual element to make sure that it is securely fastened to the adjacent element. Always verify that no one is standing underneath the product when it is being installed/raised. Never leave the product unattended during the installation process.
As a general rule, L-Acoustics recommends the use of secondary safety at all times.
- Be cautious when ground-stacking a loudspeaker array.**
Do not stack the loudspeaker array on unstable ground or surface. If the array is stacked on a structure, platform, or stage, always check that the latter can support the total weight of the array.
As a general rule, L-Acoustics recommends the use of safety straps at all times.

Risk of falling objects

Verify that no unattached items remain on the product or assembly.

Risk of tipping

Remove all rigging accessories before transporting a product or an assembly.

Take into account the wind effects on dynamic load.

When a loudspeaker assembly is deployed in an open air environment, wind can produce dynamic stress to the rigging components and suspension points.

If the wind force exceeds 6 bft (Beaufort scale), lower down and/or secure the product or the assembly.



Intended use

This system is intended for use by trained personnel for professional applications.



As part of a continuous evolution of techniques and standards, L-Acoustics reserves the right to change the specifications of its products and the content of its documents without prior notice.

Check www.l-acoustics.com on a regular basis to download the latest document and software updates.



Long term exposure to extreme conditions may damage the product.

For more information, refer to the **Products weather protection** document, available on the website.



Read the maintenance section of this document before servicing the product.



Contact L-Acoustics for advanced maintenance.

Any unauthorized maintenance operation will void the product warranty.



This marking indicates that this product should not be disposed of with other household waste throughout the EU. To prevent possible harm to the environment or human health from uncontrolled waste disposal, recycle it responsibly to promote the sustainable reuse of material resources. To return your used device, please use the return and collection systems or contact the retailer where the product was purchased. They can take this product for environmentally safe recycling.

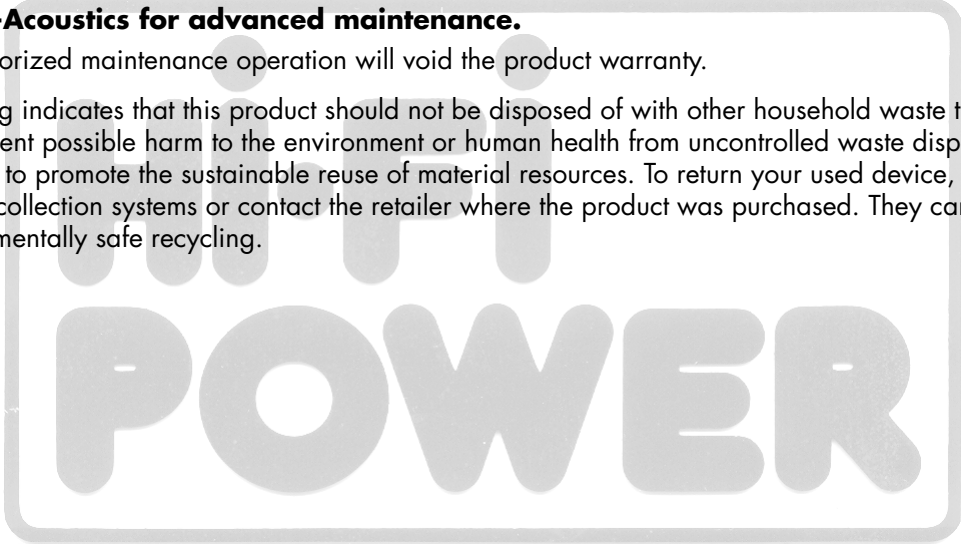

Introduction

X12 multi-purpose enclosure

The X12 is a multipurpose coaxial system perfectly suited to all short throw sound reinforcement applications. The enclosure features a 3" diaphragm compression driver coaxially loaded by a 12" low frequency transducer in a bass-reflex cabinet. The L-Vents laminar vented ports reduce turbulence and port noise at high levels to increase LF efficiency.

The X12 operates from 59 Hz to 20 kHz. The coaxial transducer arrangement and its ellipsoid acoustic design produce a 90° x 60° directivity pattern with a smooth tonal response free of secondary lobes over the entire frequency range.

The internal passive crossover network uses custom filters. The L-Acoustics amplified controllers L-Drive parameters ensure the linearization and protection of the transducers.

How to use this manual

The X12 owner's manual is intended for all actors involved in the system design, implementation, preventive and corrective maintenance of the X12 system. It must be used as follows:

1. Read the technical description for an overview of all system elements, their features, and their compatibilities.
 - [Electro-acoustical description](#) (p.11)
 - [Rigging system description](#) (p.14)
2. Prepare the system configuration. Consider the mechanical limits and the available acoustical configurations.
 - [Mechanical safety](#) (p.24)
 - [Loudspeaker configurations](#) (p.25)
3. Before rigging the system, perform mandatory inspections and functional checks.
 - [Inspection and preventive maintenance](#) (p.34)
4. To deploy the system, follow the step-by-step rigging instructions and refer to the cabling schemes.
 - [Rigging procedures](#) (p.46)
 - [Connection to LA amplified controllers](#) (p.73)



The [Corrective maintenance](#) (p.74) section contains the operations authorized for the end user. Performing another operation exposes to hazardous situations. For advanced maintenance, contact your L-Acoustics representative.

As part of a continuous evolution of techniques and standards, L-Acoustics reserves the right to change the specifications of its products and the content of its document without prior notice. Please check www.l-acoustics.com on a regular basis to download the latest document and software updates.

Contact information

For information on advanced corrective maintenance:

- contact your Certified Provider or your L-Acoustics representative
- for Certified Providers, contact the L-Acoustics customer service: customer.service@l-acoustics.com

Symbols

The following symbols are used in this document:



This symbol indicates a potential risk of harm to an individual or damage to the product.

It can also notify the user about instructions that must be strictly followed to ensure safe installation or operation of the product.



This symbol notifies the user about instructions that must be strictly followed to ensure proper installation or operation of the product.



This symbol notifies the user about complementary information or optional instructions.

Revision history

version number	publication date	modification
1.0	May 2021	<ul style="list-style-type: none"> Migrated to owner's manual format. Added KS21(i) and SB18 Ili as compatible subwoofers, removed SB18i. Updated speaker reference in Corrective maintenance section.
2.0	Dec. 2021	<ul style="list-style-type: none"> Moved and clarified information from Forbidden configurations section to Rigging system description and Rigging procedures. Updated Mechanical safety (p.24) according to EN 62368-1: 2014 standard. Added pre-alignment delay values in X12 point source with LF (p.26) for subwoofers in cardioid configuration. Fixed minor issues.

System components

Loudspeaker enclosures

X12	2-way passive coaxial enclosure: 12" LF + 3" HF diaphragm
SB15m	High power compact subwoofer : 1 x 15"
SB18	High power compact subwoofer: 1 x 18"
SB18 Ili	High power compact subwoofer: 1 x 18" (installation version)
KS21	High power compact subwoofer: 1x21"
KS21i	High power compact subwoofer: 1 x 21" (installation version)

Powering and driving system

LA4X / LA8 / LA12X	Amplified controller with DSP, preset library and networking capabilities
--------------------	---



Refer to the LA4X / LA8 / LA12X owner's manual for operating instructions.

Racks

LA-RAK	Touring rack containing three LA8 and power, audio and network distribution
LA-RAK II AVB	Touring rack containing three LA12X, LA-POWER II for power distribution, LA-PANEL II for audio and network distribution, and two LS10 for AVB distribution

Cables

SP cables	SpeakON loudspeaker cables (4-point, 4 mm ² gauge) Come in different sizes: SP.7 (0.7 m/2.3 ft), SP5 (5 m/16.4 ft), SP10 (10 m/32.8 ft), and SP25 (25 m/82 ft)
SP-Y1	Breakout cable for two passive enclosures (2.5 mm ² gauge) 4-point speakON to 2 x 2-point speakON, provided with a CC4FP adapter
DO cables	PA-COM loudspeaker cables (8-point, 4 mm ² gauge) Come in different sizes: DO.7 (0.7 m/2.3 ft), DO.10 (10 m/32.8 ft), and DO.25 (25 m/82 ft)
DOSUB-LA8	Breakout cable for four passive enclosures (4 mm ² gauge) 8-point PA-COM to 4 x 2-point speakON

i Information about the connection of the enclosures to the LA amplified controllers is given in this document.

Refer to the LA4X / LA8 / LA12X owner's manual for detailed instructions about the whole cabling scheme, including modulation cables and network.

Rigging elements

X-UL12	Long U-bracket for X12
X-US1215	Short U-bracket for X12 and X15 HiQ
X-UTILT	U-bracket wallmount for X series with tilt adjustment
X-BAR	Rigging bar for 1 enclosure
EMBi	Pole mount socket: 8XTi/12XTi and X series
CLAMP250	Clamp certified for 250 kg

Software applications

Soundvision	3D acoustical and mechanical modeling software
LA Network Manager	Software for remote control and monitoring of amplified controllers

i Refer to the **Soundvision** help.
Refer to the **LA Network Manager** help.

System component illustrations

Cables

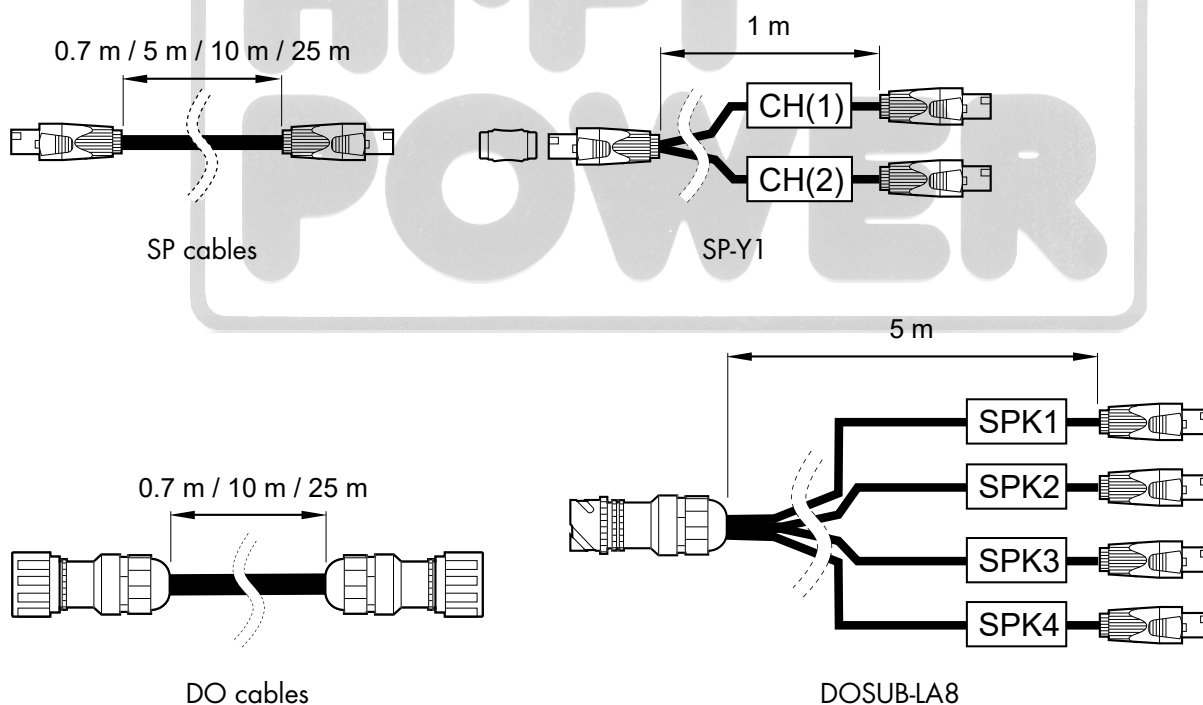

Rigging accessories

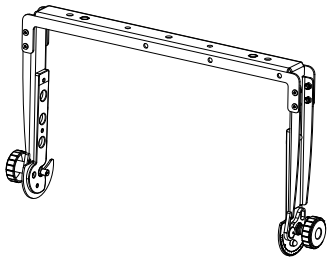

X-UL12

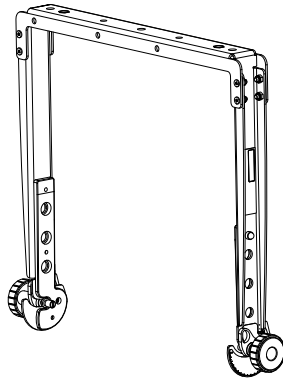

X-US1215

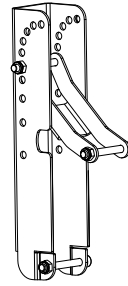

X-UTILT

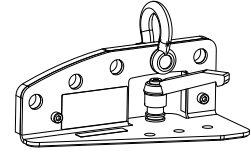

X-BAR

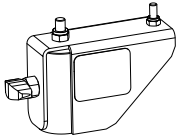

EMBi

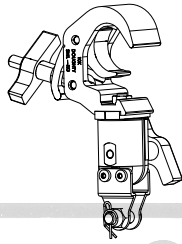

CLAMP250

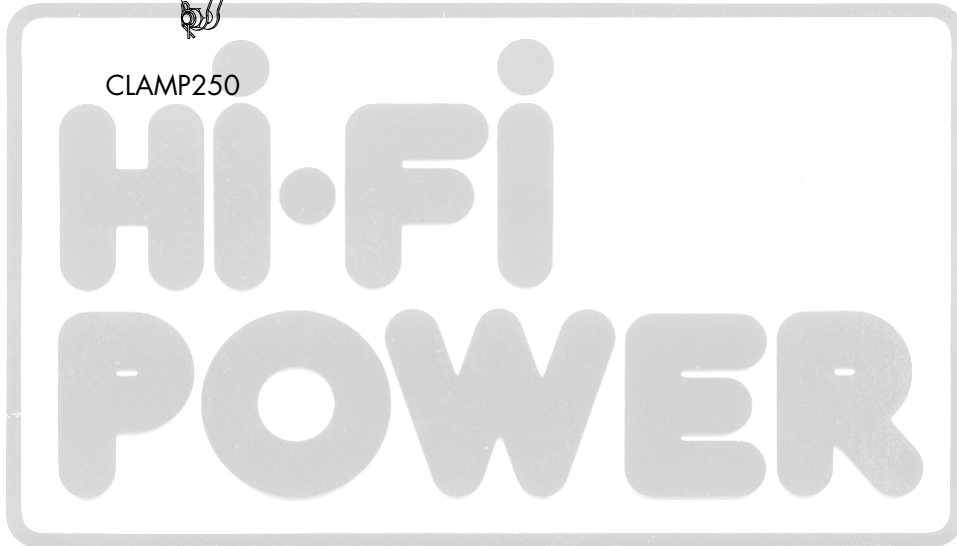

Electro-acoustical description

Directivity

X12 features a coaxial transducer arrangement coupled with an ellipsoid waveguide that generates an H/V directivity pattern of $60^\circ \times 90^\circ$.

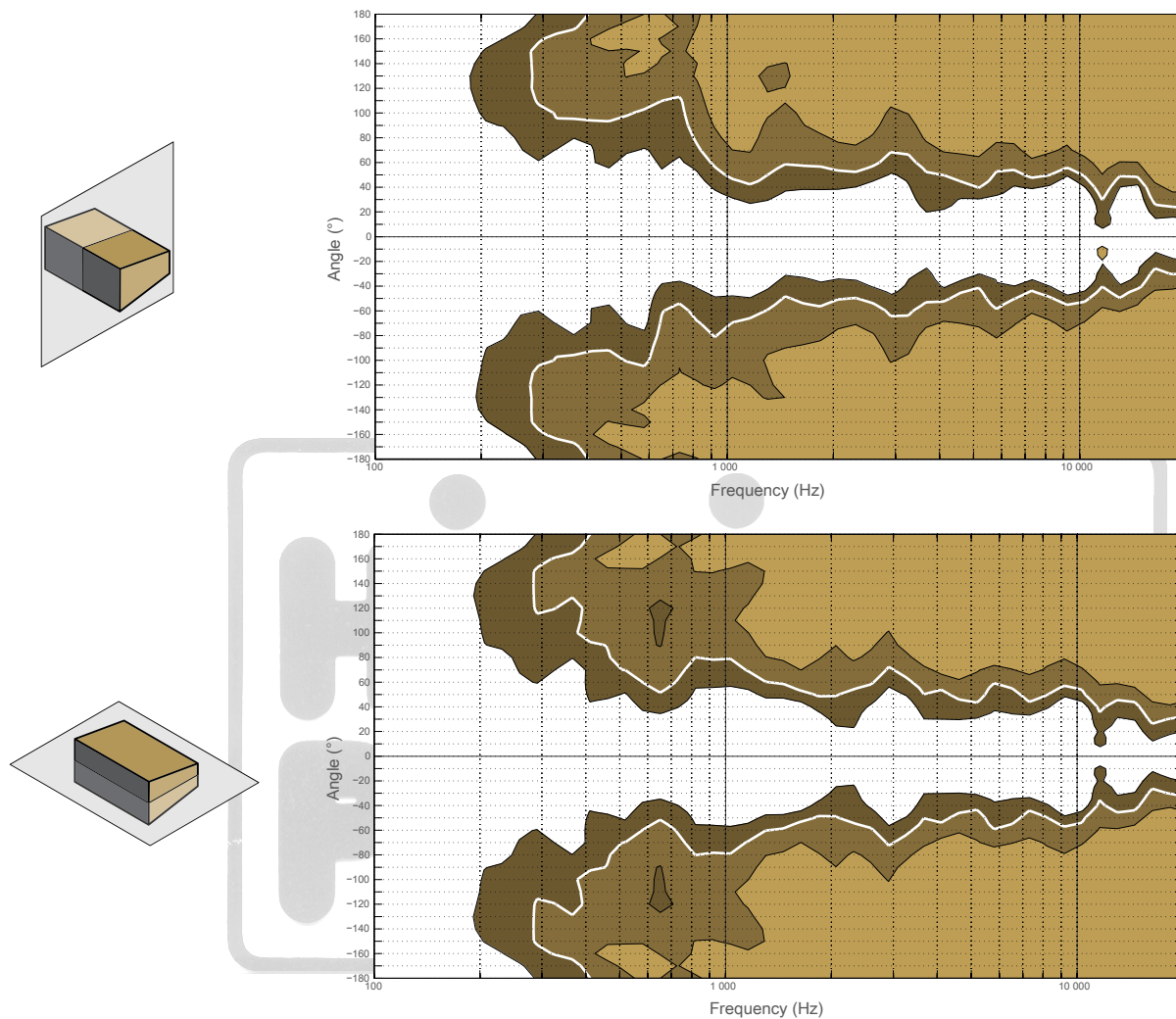

Dispersion angle diagram of a single X12 using lines of equal sound pressure at -3 dB, -6 dB, -12 dB.

Monitor angles

X12 features risers that allow to change the monitor angle from 35° to 55°.

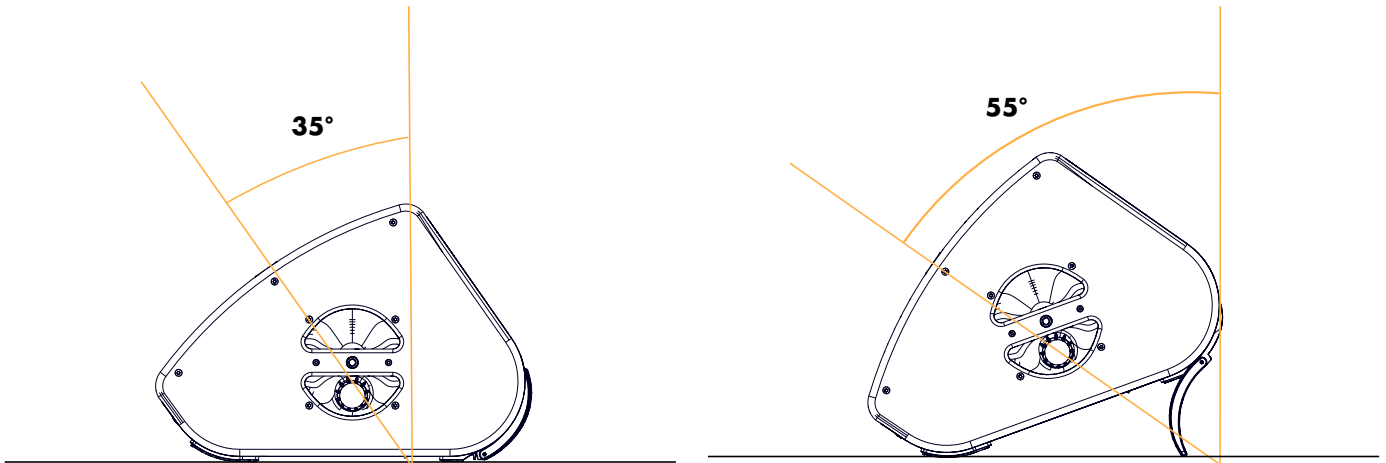

Preset description

[X12] [X12_MO]

outputs	channels	routing	gain	delay	polarity	mute
OUT 1	PA	IN A	0 dB	0 ms	+	ON
OUT 2	PA	IN A	0 dB	0 ms	+	ON
OUT 3	PA	IN B	0 dB	0 ms	+	ON
OUT 4	PA	IN B	0 dB	0 ms	+	ON

[KS21_60] [KS21_100] [SB18_100] [SB15_100]

outputs	channels	routing	gain	delay	polarity	mute
OUT 1	SB	IN A	0 dB	0 ms	+	ON
OUT 2	SB	IN A	0 dB	0 ms	+	ON
OUT 3	SB	IN A	0 dB	0 ms	+	ON
OUT 4	SB	IN A	0 dB	0 ms	+	ON

[KS21_60_C] [KS21_100_C] [KS21_60_Cx] [KS21_100_Cx] [SB18_100_C] [SB18_100_Cx] [SB15_100_C] [SB15_100_Cx]

loudspeaker elements	outputs	channels	routing	gain	delay	polarity	mute
SR	OUT 1	SR	IN A	0 dB	0 ms	+	ON
SB	OUT 2	SB					ON
SB	OUT 3	SB					ON
SB	OUT 4	SB					ON

Connectors



SpeakON connectors can be used interchangeably as IN or LINK connector.

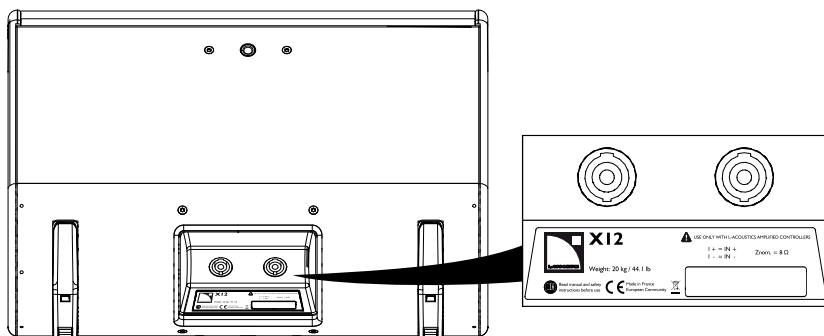

X12

2 × 4-point speakON

Internal pinout for L-Acoustics 2-way passive enclosures

SpeakON points	1 +	1 -	2 +	2 -
Transducer connectors	+	-	Not linked	Not linked

HI-FI
POWER

Rigging system description

X12

X12 features a M8 DIN580 threaded insert designed to implement a secondary safety.

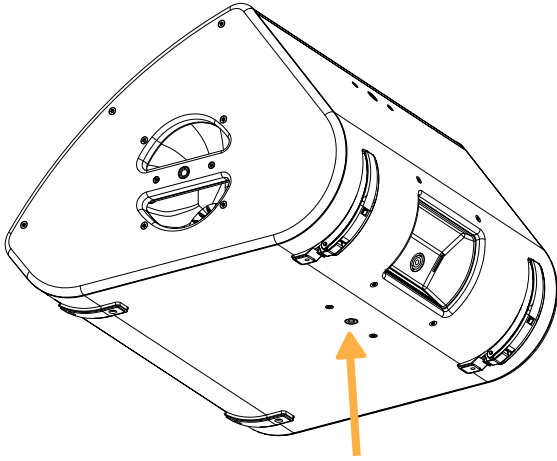

The logo on the enclosure front can be rotated to adapt to every configuration.

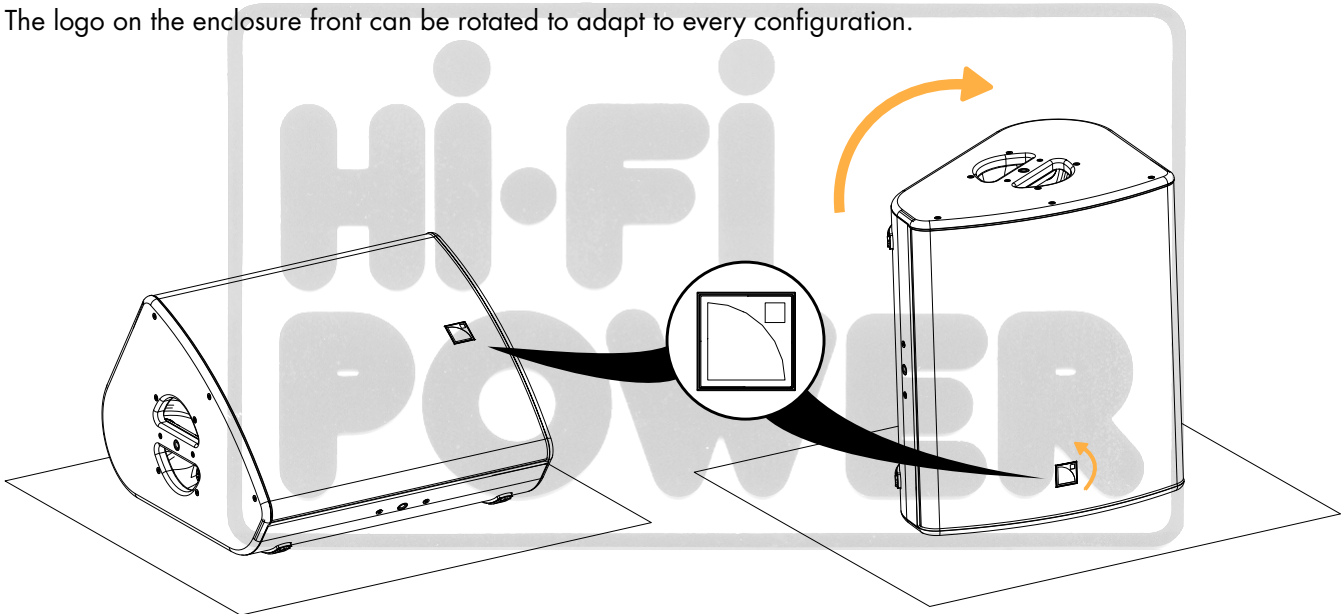

X12 features ergonomic handles on both sides for easy transportation.

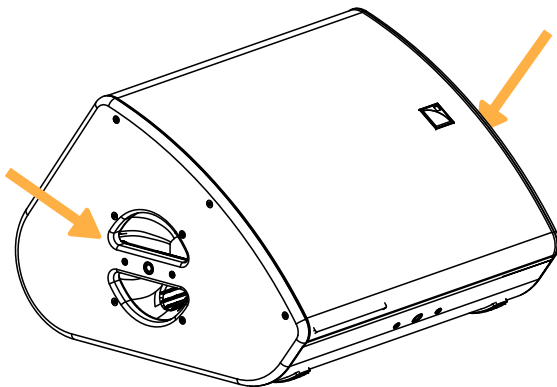

X12 features four runners on the bottom to protect the enclosure.

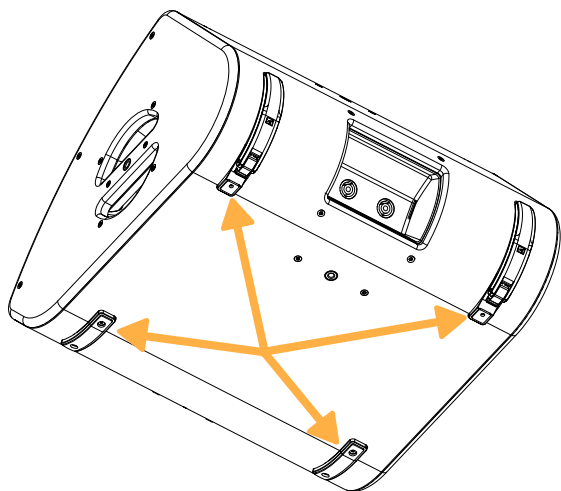

X12 features risers that allow to change the monitor angle from 35° to 55° relative to the vertical.

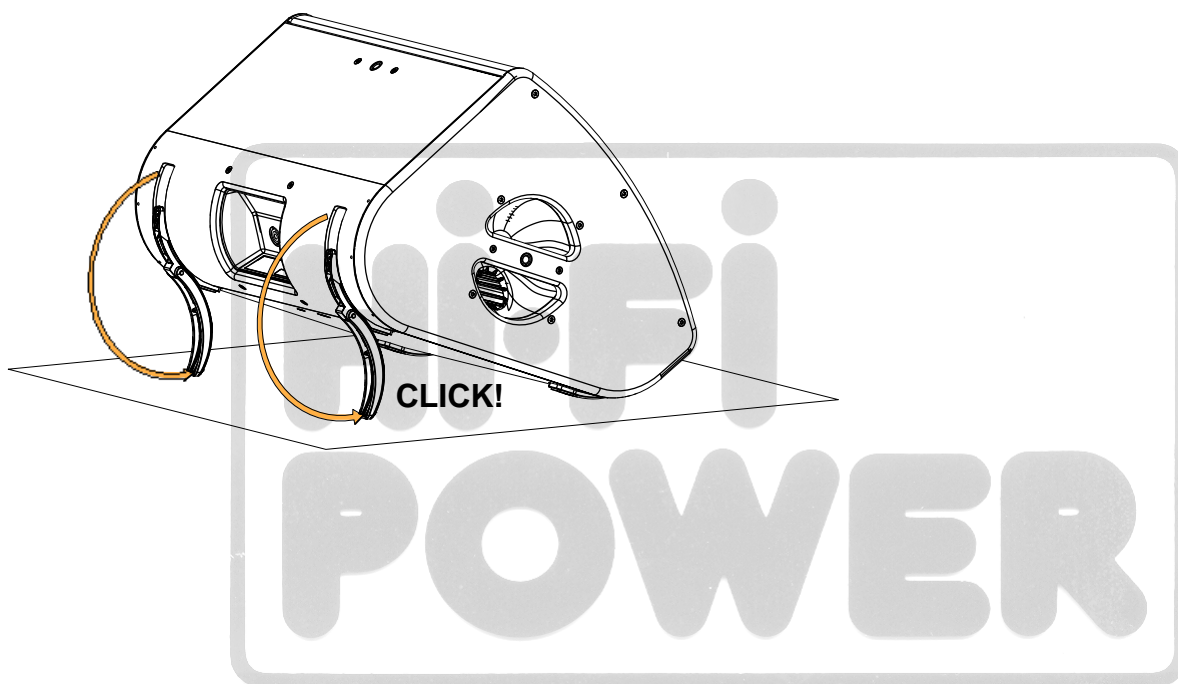

Elements for flying and wall-mounting

X-US1215 and X-UL12

X12 can be fitted with a short U-bracket, X-US1215, or a long U-bracket, X-UL12. The brackets are secured in the enclosure inserts with two threaded knobs. A spring-lock safety mechanism secures the knobs in the U-brackets.

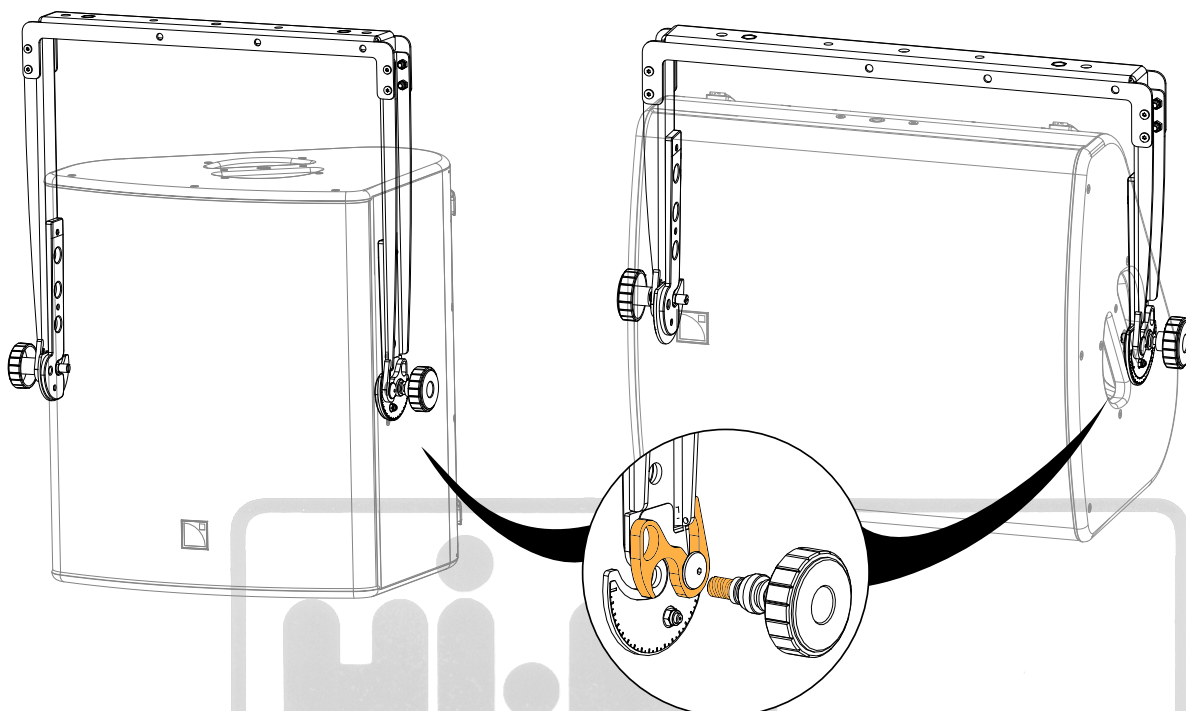

The threaded knobs feature a washer as a safety to avoid the accidental loosening of the knob.

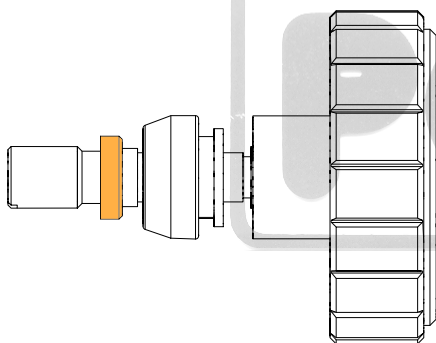

X-US1215 and X-UL12 can be used for wall-mounting, ceiling-mounting or flying X12.



Short U-bracket in horizontal position

In this position, the enclosure applies a diagonal force of **405 daN** on the anchoring points.

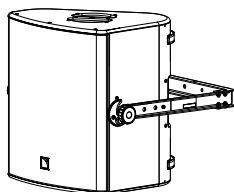

Fasteners for wall-mounting or ceiling-mounting

Secure the bracket with three M10 screws.

Select screw length and anchors applicable to the wall or ceiling properties.

! When wall-mounting X12 horizontally with X-US1215, it is recommended to mount the enclosure with the logo on the left. In this position, the cabinet is resting on the bracket's gasket, which prevents the enclosure from rotating.

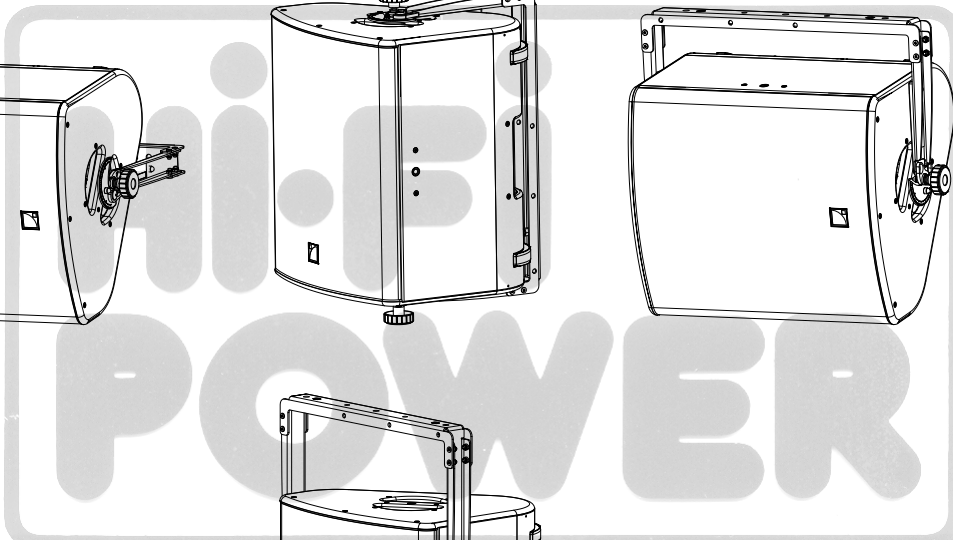
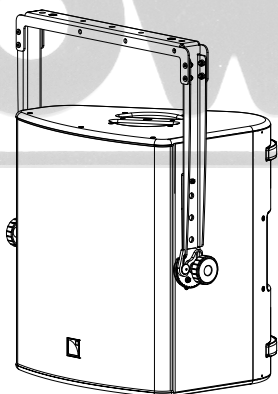
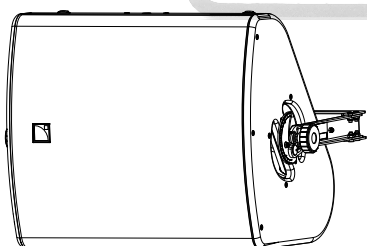
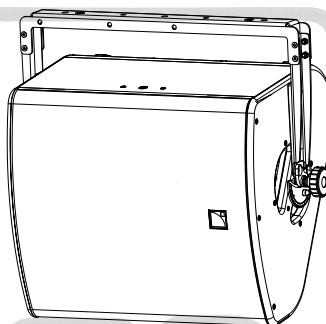
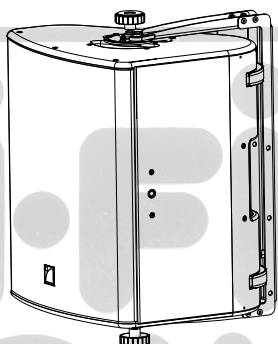
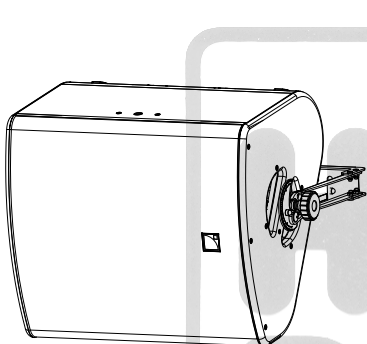
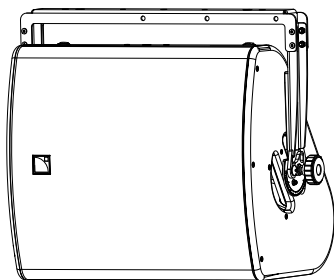
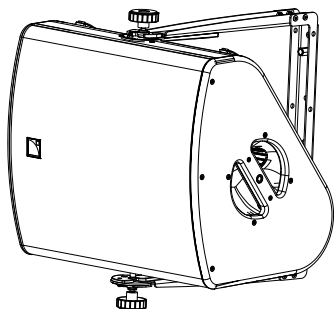
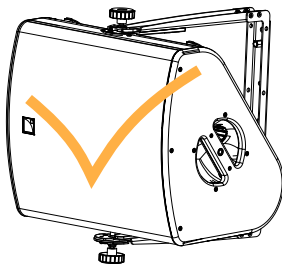
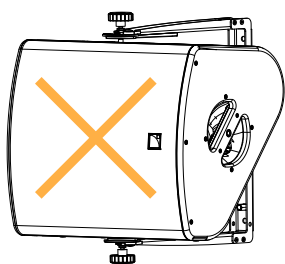

i When using the additional holes, consider the maximum site angle available.

See [Maximum angles](#) (p.61).

X-US1215 features additional holes on the sides to closely fit the enclosure and to minimize visual impact.

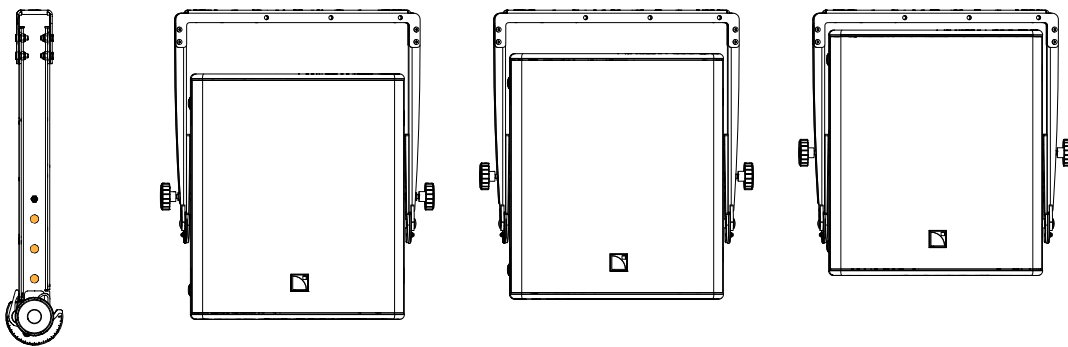

The knobs shall be stored in the U-brackets.

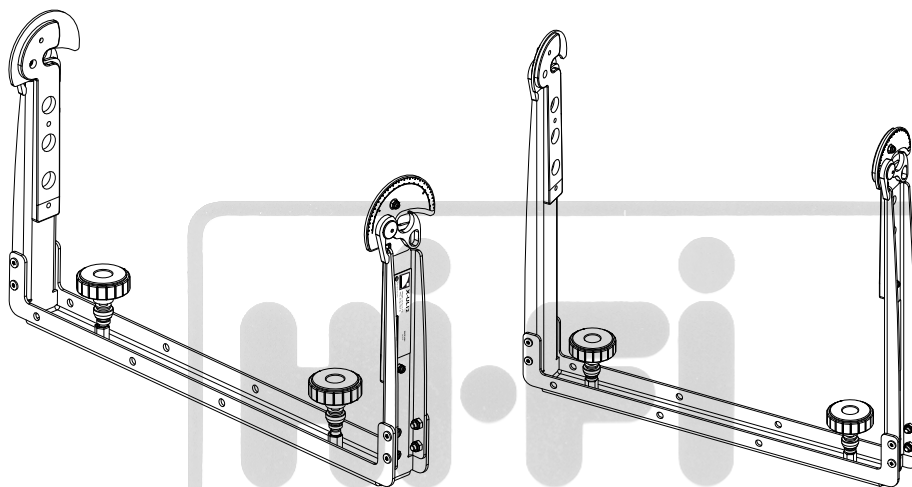

X-UTILT

X-UTILT is a tilt adjustment accessory compatible with X-US1215 and X-UL12. X-UTILT provides negative site angle setting combined with azimuth angle setting capabilities in a wall-mount configuration. The site angle can be set from 0° to -45° in 5° steps. The azimuth angle can be adjusted with the U-bracket.

! X-UTILT intended use

Use X-UTILT only vertically and for negative site angles.

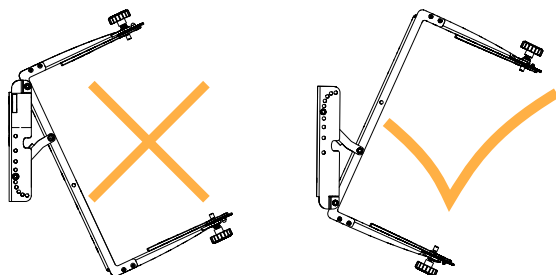

! Assembling X-UTILT with X-US1215 or X-UL12

X-US1215 and X-UL12 have three holes for assembling with X-UTILT. Use hole 1 (furthest from the label) to secure the U-bracket to X-UTILT, and hole 2 to secure the rigging arm. Hole 3 is reserved for storage (0° site angle).

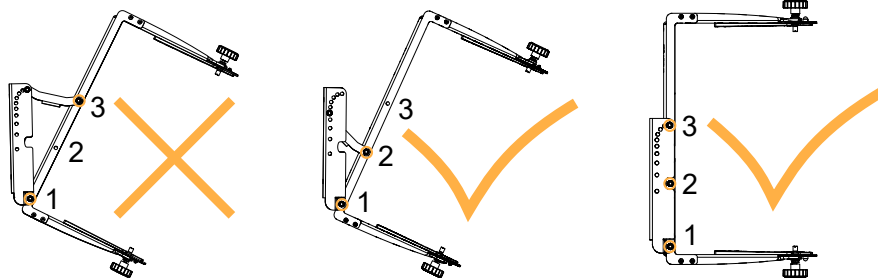

! Fasteners for wall-mounting

Secure X-UTILT with two M10 screws.
 Select screw length and anchors applicable to the wall properties.

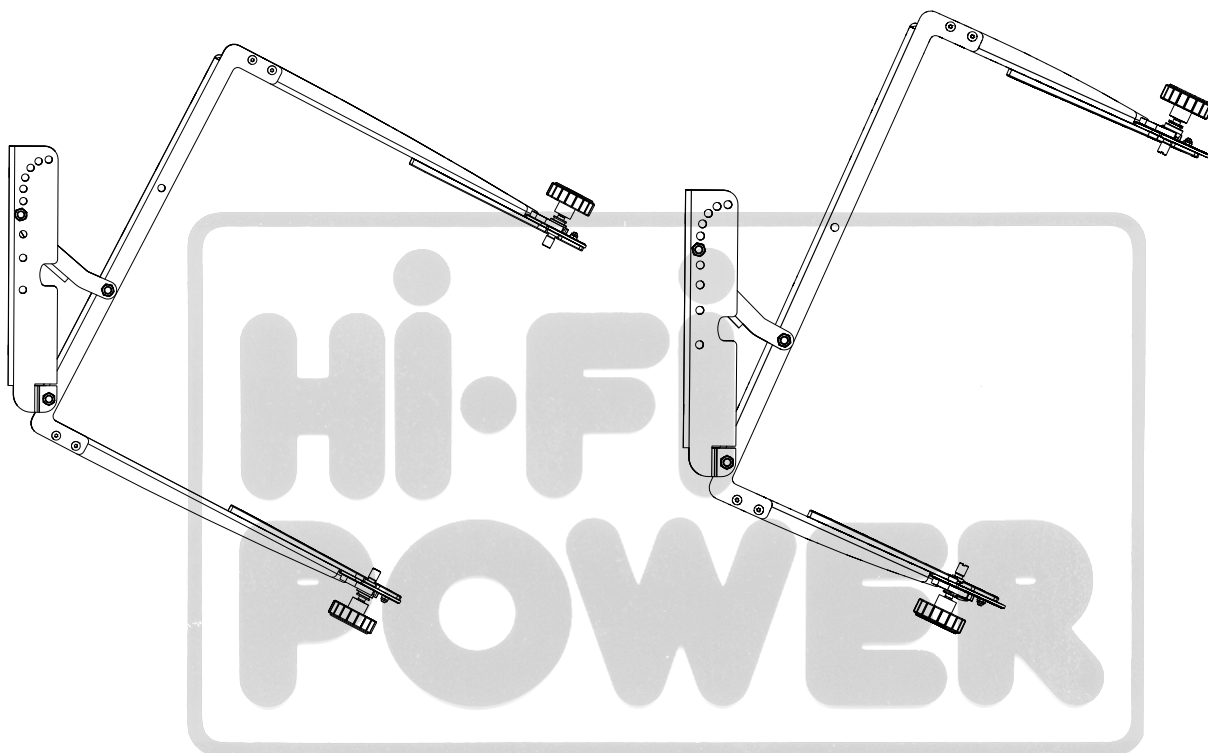

X-BAR

X-BAR is a rigging bar for flying X12. The rigging system consists of a threaded axis with a cam lever.

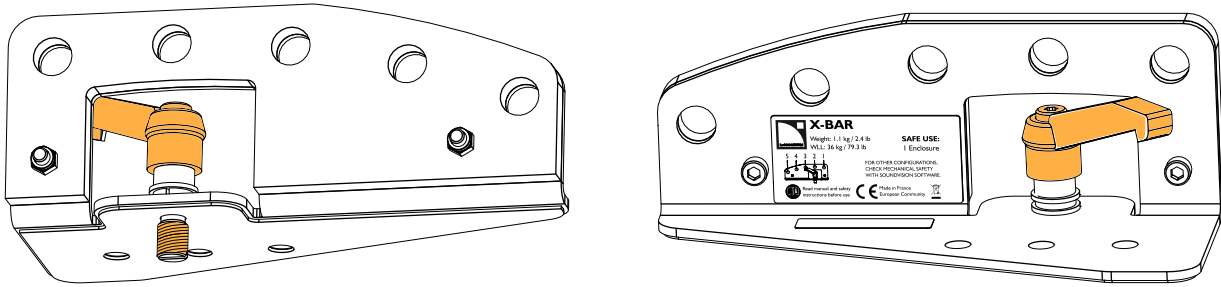

X-BAR is secured to the dedicated inserts on the enclosure, in front or rear extension position.

⚠ Risk of damaging the insert and the cabinet
When flying X12 horizontally with X-BAR, always use the insert on the largest side (logo on the right). On the opposite side, the contact area between X-BAR and the cabinet is too small, which can cause the insert to be damaged through lever effect.

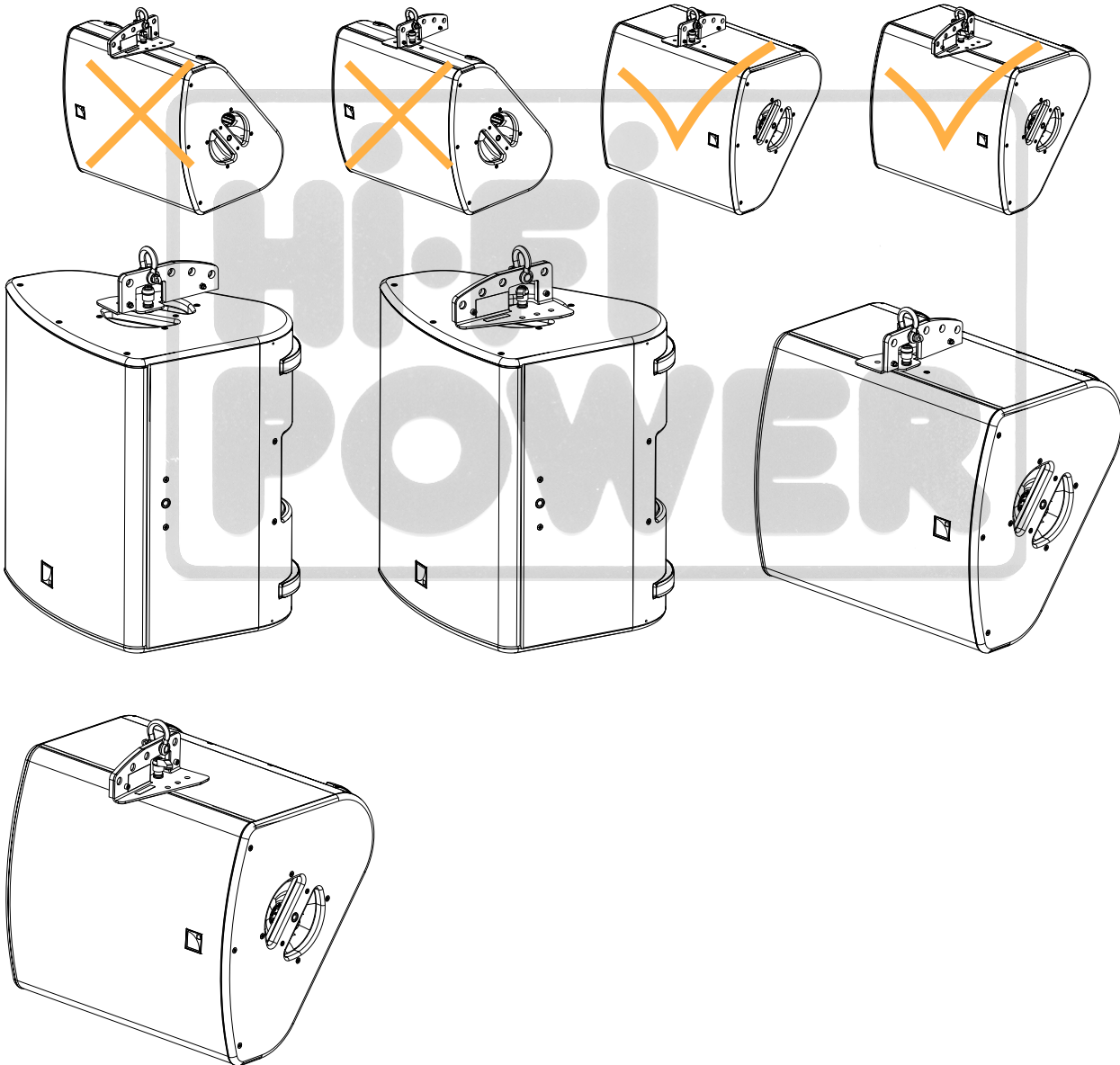

Five angulation holes are available.

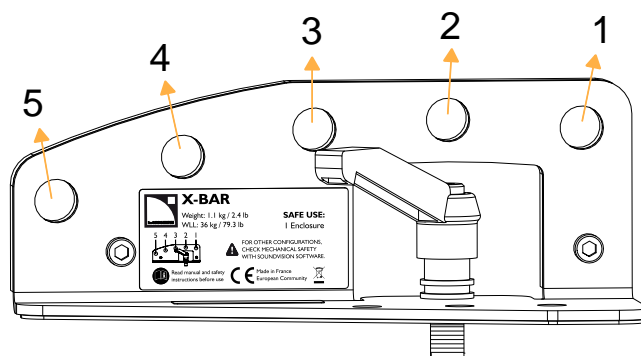

X-BAR is compatible with a Ø12 mm shackle WLL 1 t (provided) and with CLAMP250.

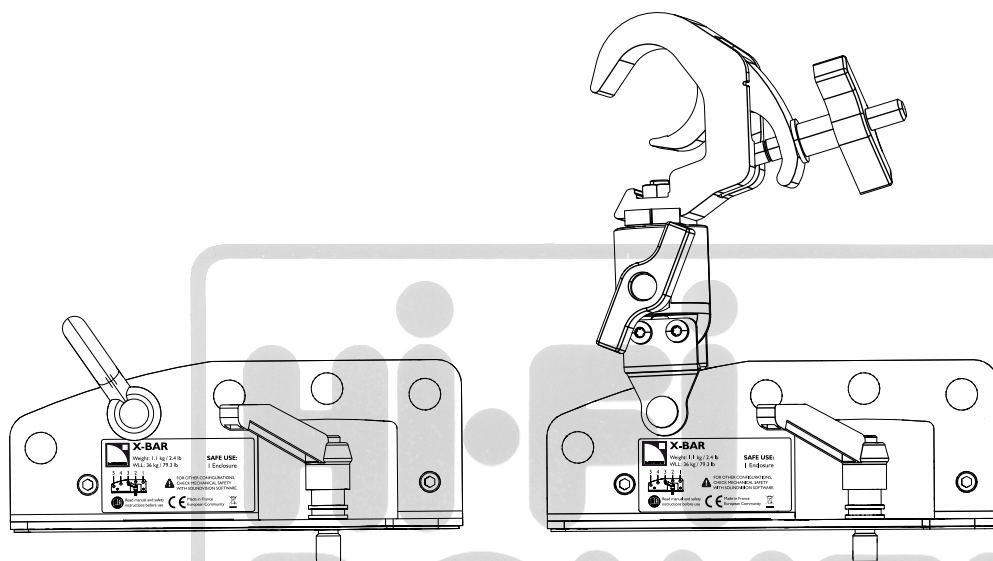

Elements for pole-mounting

Pole sockets

X12 features two 35 mm pole sockets integrated in the handles.

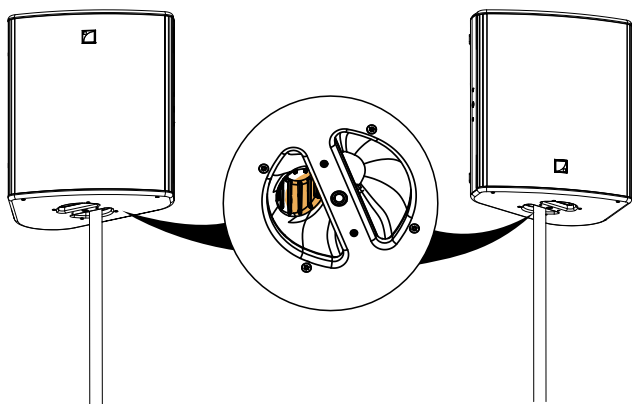

EMBi

EMBi is a pole-mount adapter for X-US1215 (35 mm pole). The site angle can be adjusted with the U-bracket.



Risk of damaging the bracket safety mechanism

When using X-US1215 and EMBi for pole-mounting X12, always use the additional holes on the bracket. Do not use X-UL12 with EMBi.

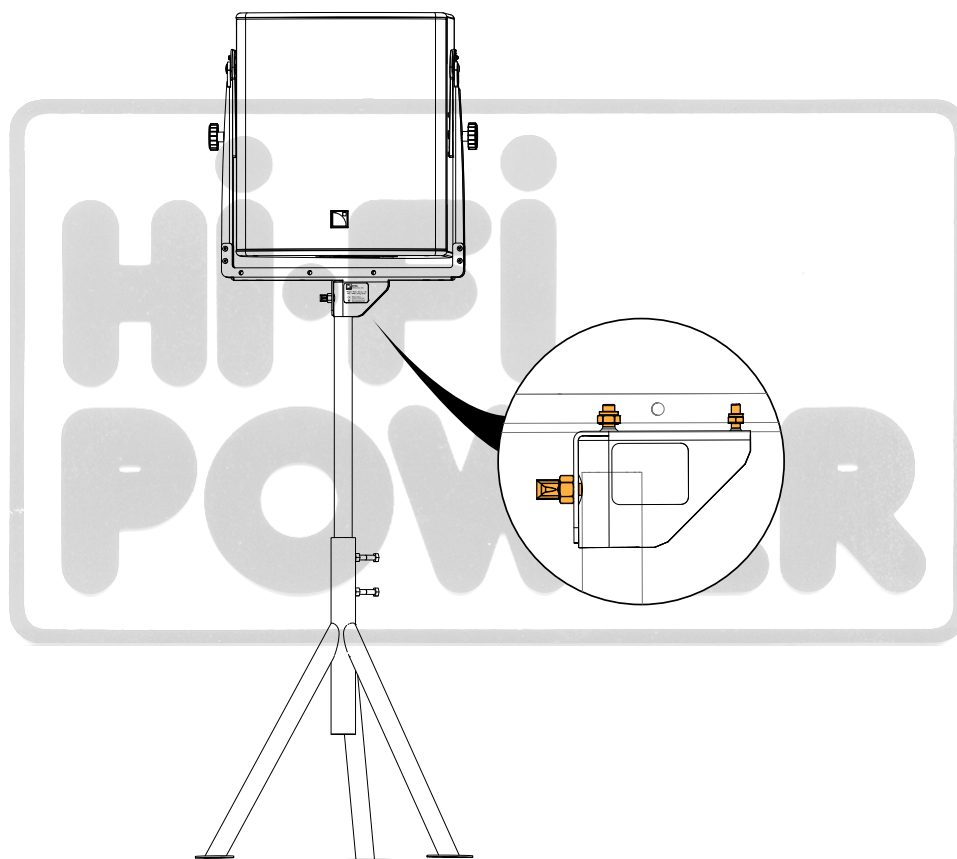
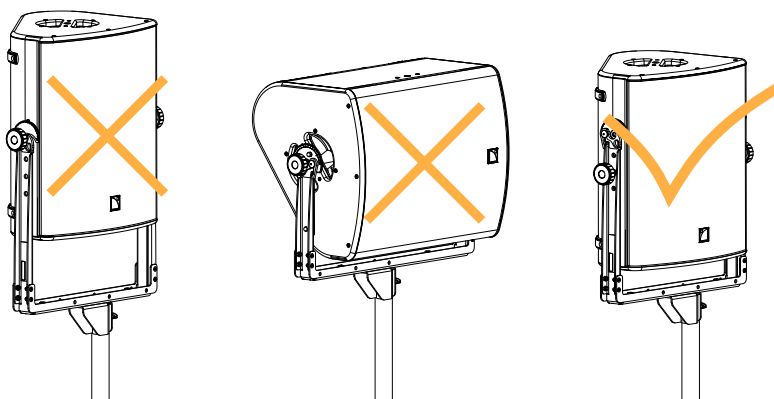

Subwoofers

KS21, SB18, and SB15m feature a 35 mm pole socket.

KS21 features a 35 mm pole-socket which contains an M20×150 insert.



Use a 35 mm diameter pole

The pole can be non-threaded or with M20 thread.

Use an adapter for poles with other dimensions, for example the 21329 adapter by K&M, available on www.k-m.de/en.

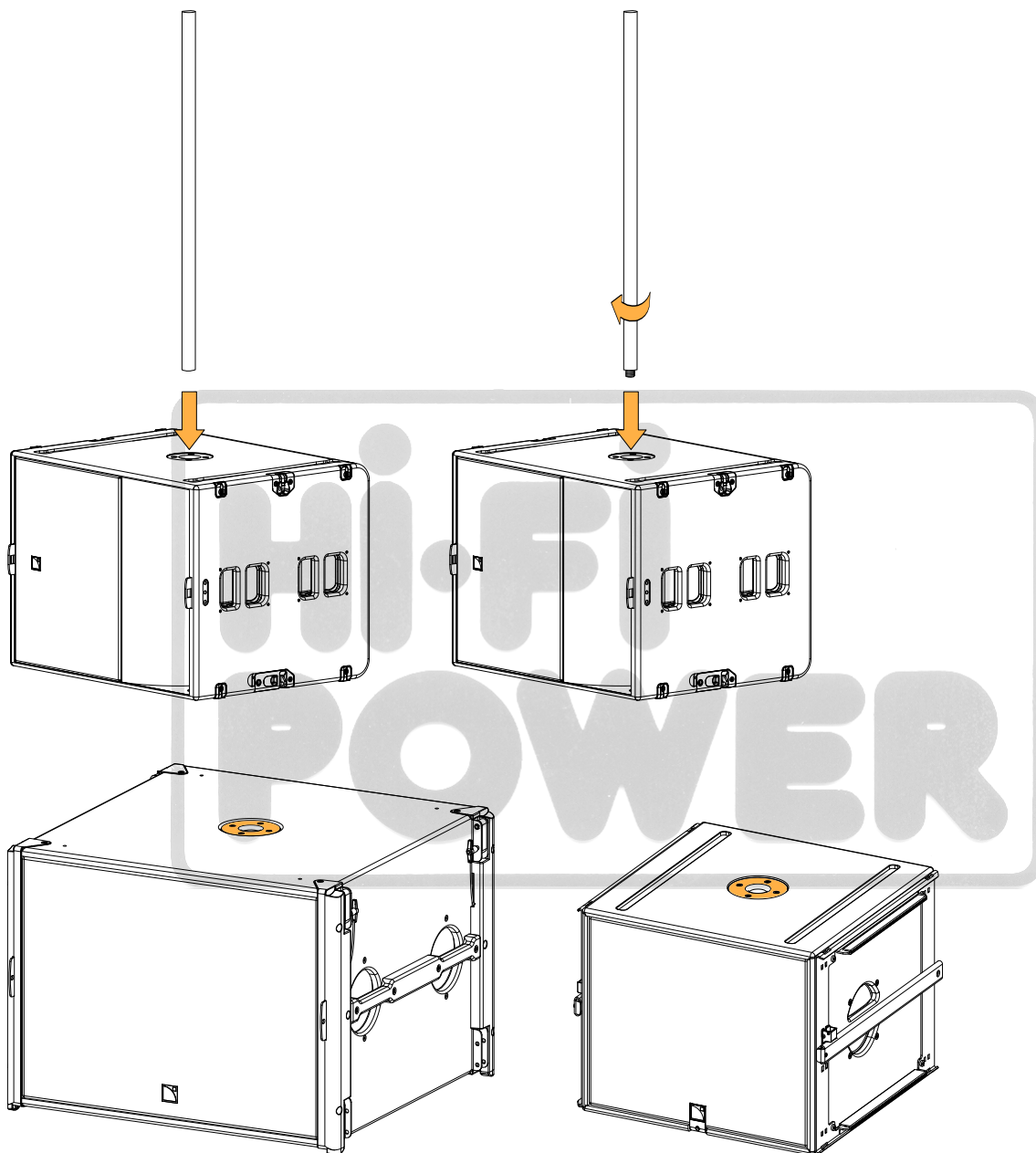

Mechanical safety

The X12 rigging system complies with EN 62368-1: 2014 Audio/video, information and communication technology equipment – Part 1: Safety requirements.

The deployments described in this manual achieve a safety factor of **5**.

X12

Configuration	Rigging accessory	Maximum / Safe limit
Wall-mounted	X-US1215 / X-UL12 + X-UTILT (optional)	1
Ceiling-mounted	X-US1215 / X-UL12	1
Flown	X-BAR + CLAMP250	1
Pole-mounted	35 mm pole + EMBi and X-US1215 (optional)	1
Ground-stacked	No rigging accessory	1



Additional safety for flown arrays

When flying an enclosure, use the M8 DIN580 threaded insert to implement a secondary safety.

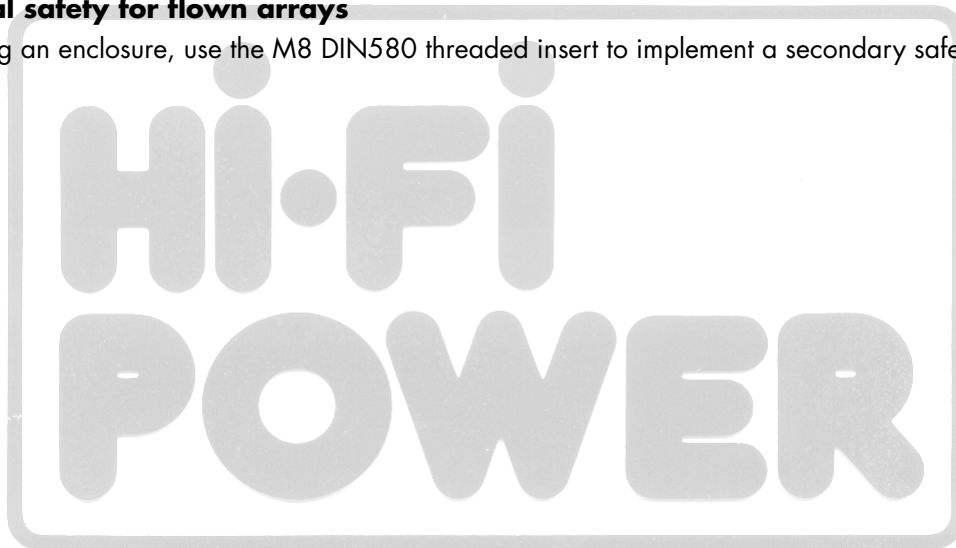

Loudspeaker configurations

X12 point source

Deployed as a standalone point source, an X12 system operates over the nominal bandwidth of the X12 enclosure.

The [X12] preset delivers a reference frequency response in short throw applications.

The X12 enclosure is driven by the LA4X / LA8 / LA12X amplified controllers.

Standalone X12

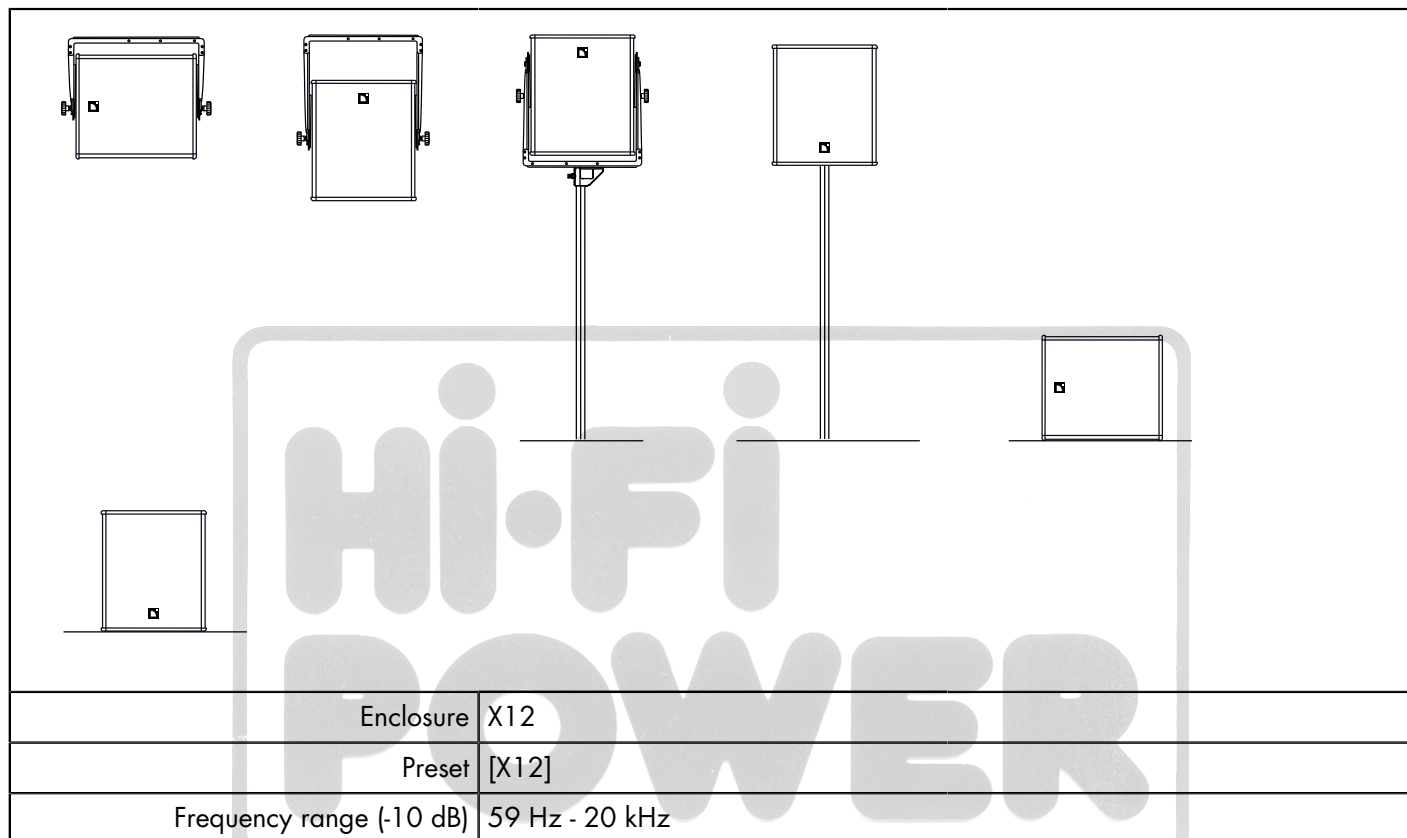

X12 point source with LF

Deployed as a point source with SB15m, SB18, or KS21 subwoofers, an X12 system operates with augmented LF resources.

The [X12] preset delivers a reference frequency response in short throw applications.

The [SB15_100], [SB18_100] and [KS21_100] presets provide the SB15m, SB18 and KS21 with an upper frequency limit at 100 Hz for an optimal frequency coupling with the X12.

The X12, SB15m, SB18 and KS21 enclosures are driven by the LA4X / LA8 / LA12X amplified controllers.

X12 with SB15m

With SB15m, the X12 system contour is reinforced by 8 dB at 100 Hz and the system bandwidth is extended down to 40 Hz.

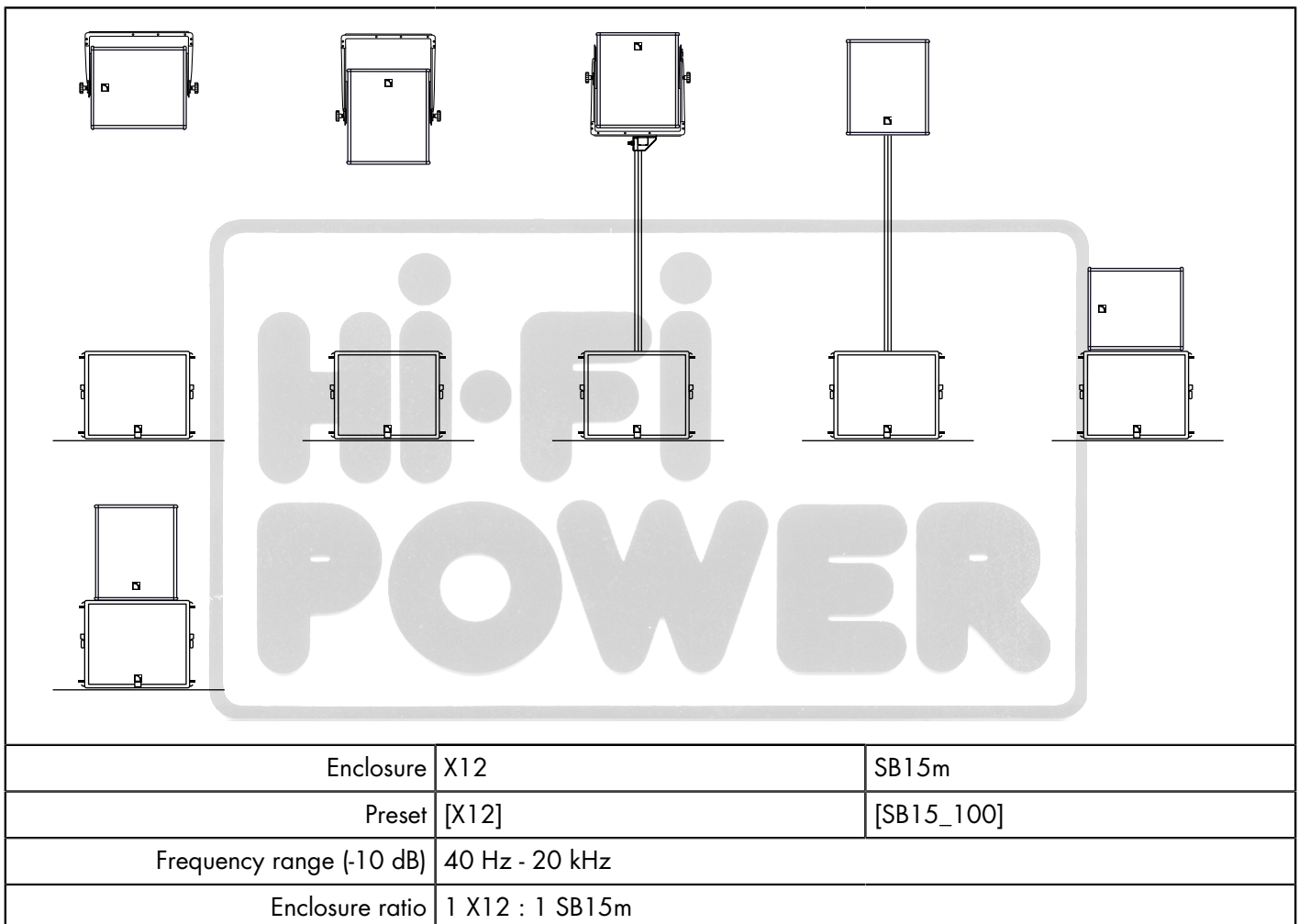

! Grouping subwoofers

Place the subwoofer enclosures side by side. If not possible, the maximum distance between two adjacent acoustic centers must be 1.7 m if the upper frequency limit of the subwoofer system is at 100 Hz.

! Use [xxxx_xx_C] or [xxxx_xx_Cx] on a reversed subwoofer in a cardioid configuration

The cardioid configuration consists in reversing 1 element in an array of 4 subwoofers.

Refer to the subwoofer owner's manual and to the **Cardioid configurations** technical bulletin.

! Delay values

Do not forget to add the pre-alignment and geometric delays depending on the configuration.

Pre-alignment delays

presets	pre-alignment delay values and polarity settings		
[X12] + [SB15_100]	X12 = 1.5 ms	+	SB15m = 0 ms -
[X12] + [SB15_100_C]	X12 = 5.1 ms	+	SB15m = 0 ms -
[X12] + [SB15_100_Cx]	X12 = 3 ms	+	SB15m = 0 ms -

X12 with SB18

With SB18, the X12 system contour is reinforced by 4 dB at 60 Hz and 5 dB at 100 Hz, and the system bandwidth is extended down to 32 Hz.



Values and ratios are the same for SB18 Ili.



SB18 Ili is not mechanically compatible with pole-mounted configurations.

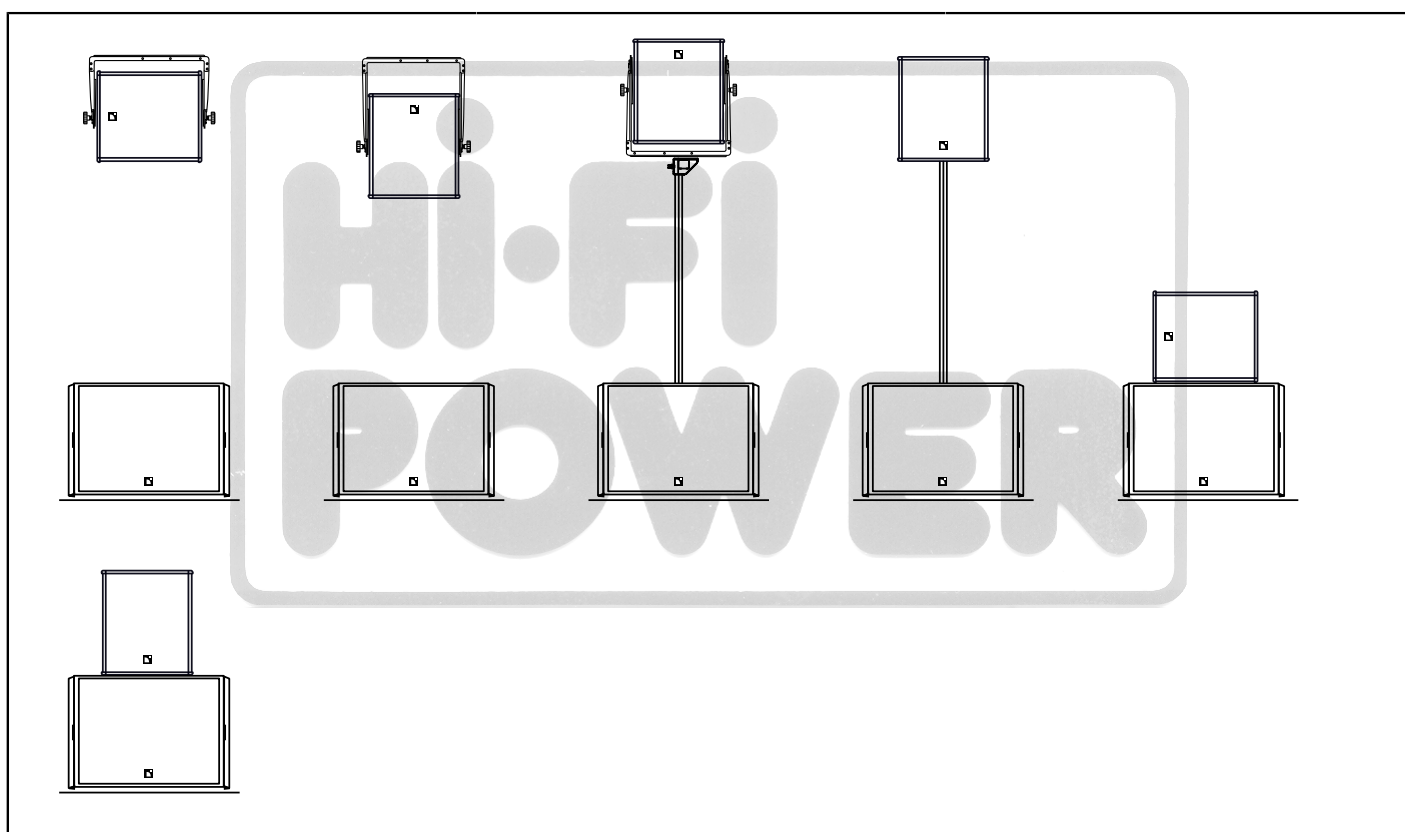

	Enclosure	X12	SB18
	Preset	[X12]	[SB18_100]
	Frequency range (-10 dB)	32 Hz - 20 kHz	
	Enclosure ratio	1 X12 : 1 SB18	



Grouping subwoofers

Place the subwoofer enclosures side by side. If not possible, the maximum distance between two adjacent acoustic centers must be 1.7 m if the upper frequency limit of the subwoofer system is at 100 Hz.



Use [xxxx_xx_C] or [xxxx_xx_Cx] on a reversed subwoofer in a cardioid configuration

The cardioid configuration consists in reversing 1 element in an array of 4 subwoofers.

Refer to the subwoofer owner's manual and to the **Cardioid configurations** technical bulletin.

! Delay values

Do not forget to add the pre-alignment and geometric delays depending on the configuration.

Pre-alignment delays

presets	pre-alignment delay values and polarity settings	
[X12] + [SB18_100]	X12 = 0 ms <input style="float: right;" type="checkbox" value="+"/>	SB18 = 0 ms <input style="float: right;" type="checkbox" value="+"/>
[X12] + [SB18_100_C]	X12 = 5.7 ms <input style="float: right;" type="checkbox" value="+"/>	SB18 = 0 ms <input style="float: right;" type="checkbox" value="+"/>
[X12] + [SB18_100_Cx]	X12 = 4 ms <input style="float: right;" type="checkbox" value="+"/>	SB18 = 0 ms <input style="float: right;" type="checkbox" value="-"/>

X12 with KS21

With KS21, the X12 system contour is reinforced by 6 dB at 60 Hz and 2 dB at 100 Hz, and the system bandwidth is extended down to 31 Hz.

i Values and ratios are the same for KS21i.

! KS21i is not mechanically compatible with pole-mounted configurations.

Enclosure	X12	SB18
Preset	[X12]	[KS21_100]
Frequency range (-10 dB)	31 Hz - 20 kHz ([KS21_100])	
Enclosure ratio	1 X12 : 1 KS21	

! Grouping subwoofers

Place the subwoofer enclosures side by side. If not possible, the maximum distance between two adjacent acoustic centers must be 1.7 m if the upper frequency limit of the subwoofer system is at 100 Hz.

! Use [xxxx_xx_C] or [xxxx_xx_Cx] on a reversed subwoofer in a cardioid configuration

The cardioid configuration consists in reversing 1 element in an array of 4 subwoofers.

Refer to the subwoofer owner's manual and to the **Cardioid configurations** technical bulletin.

! Delay values

Do not forget to add the pre-alignment and geometric delays depending on the configuration.

Pre-alignment delays

presets	pre-alignment delay values and polarity settings	
[X12] + [KS21_100]	X12 = 0 ms <input style="float: right;" type="checkbox" value="+"/>	KS21 = 1 ms <input style="float: right;" type="checkbox" value="+"/>
[X12] + [KS21_100_C]	X12 = 4.8 ms <input style="float: right;" type="checkbox" value="+"/>	KS21 = 0 ms <input style="float: right;" type="checkbox" value="+"/>
[X12] + [KS21_100_Cx]	X12 = 3.4 ms <input style="float: right;" type="checkbox" value="+"/>	KS21 = 0 ms <input style="float: right;" type="checkbox" value="-"/>

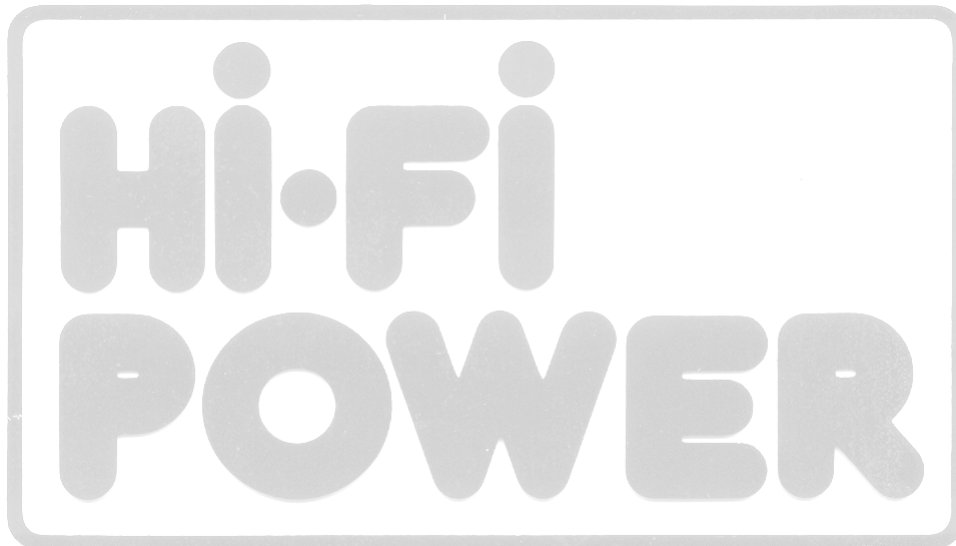

X12 stage monitor

Deployed as a stage monitor, an X12 system operates over the nominal bandwidth of the X12 enclosure.

The [X12_MO] preset delivers a reference frequency response in stage monitoring applications.

The X12 enclosure is driven by LA4X / LA8 / LA12X.

Standalone X12

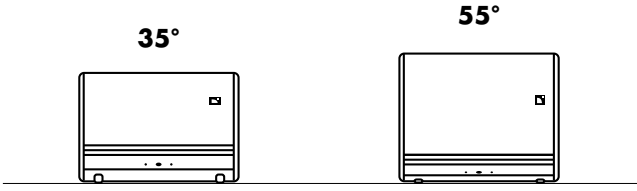
	
Enclosure	X12
Preset	[X12_MO]
Frequency range (-10 dB)	57 Hz - 20 kHz

Low-latency preset

A low-latency preset is available for the X12 enclosure used as a monitor ([X12_MO]). It reduces latency from 3.84 ms down to 1.18 ms (LA8) and 0.84 ms (LA4X / LA12X). If the monitor is combined with a subwoofer, a custom preset must be used.

Paired X12 monitors with LFC

The Low Frequency Contour (LFC) tool implemented in LA Network Manager can compensate for coupling effects between closely operating monitors. LFC allows to adjust the frequency response curve to obtain the desired low frequency contour.

For paired X12 monitors, enter the following parameters to obtain the reference response curve of a single enclosure:

LF Contour		N/A
FREQ/RATIO	180	
GAIN	-3.0	

For more information about LFC, refer to the **LA Network Manager Help** (section: Group Control Panel) and to the **Array Morphing** white paper, available on www.l-acoustics.com.

X12 stage monitor with LF

Deployed as a stage monitor with SB15m, SB18 or KS21 subwoofers, an X12 system operates with augmented LF resources.

The [X12_MO] preset delivers a reference frequency response in stage monitoring applications.

The [SB15_100], [SB18_100] and [KS21_100] presets provide the SB15m, SB18 and KS21 with an upper frequency limit at 100 Hz for an optimal frequency coupling with the X12.

The X12, SB15m, SB18 and KS21 enclosures are driven by the LA4X / LA8 / LA12X amplified controllers.

X12 with SB15m

With SB15m, the X12 system contour is reinforced by 8 dB at 100 Hz and the system bandwidth is extended down to 40 Hz.

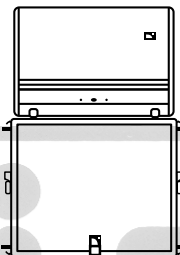
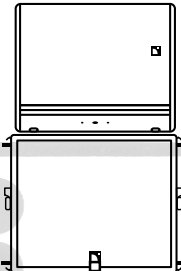
	35°	55°
		
Enclosure	X12	SB15m
Preset	[X12_MO]	[SB15_100]
Frequency range (-10 dB)	40 Hz - 20 kHz	
Enclosure ratio	1 X12 : 1 SB15m	

! Delay values

Do not forget to add the pre-alignment and geometric delays depending on the configuration.

Pre-alignment delays

presets	pre-alignment delay values and polarity settings	
[X12_MO] + [SB15_100]	X12 = 1.7 ms <input type="checkbox"/>	SB15m = 0 ms <input type="checkbox"/>

! [xx_MO] presets for the X series use the amplified controller low latency operating mode. When used along with subwoofers, it is recommended to use the subwoofers in low latency operating mode. To achieve this, create custom presets combining low latency channel sets and subwoofer channel sets.

If the subwoofers are driven from a dedicated amplified controller using a subwoofer factory preset, they are operated in normal latency mode. Therefore, an additional delay should be set to the [xx_MO] low latency channels to align them: 2.66 ms on LA8 or 3.00 ms on LA4X and LA12X.

X12 with SB18

With SB18, the X12 system contour is reinforced by 4 dB at 60 Hz and 5 dB at 100 Hz, and the system bandwidth is extended down to 32 Hz.



Values and ratios are the same for SB18 Ili.

	35°	55°
Enclosure	X12	SB18
Preset	[X12_MO]	[SB18_100]
Frequency range (-10 dB)	32 Hz - 20 kHz	
Enclosure ratio	1 X12 : 1 SB18	



Delay values

Do not forget to add the pre-alignment and geometric delays depending on the configuration.

Pre-alignment delays

presets	pre-alignment delay values and polarity settings	
[X12_MO] + [SB18_100]	X12 = 0.6 ms <input style="float: right;" type="button" value="+"/>	SB18 = 0 ms <input style="float: right;" type="button" value="+"/>



[xx_MO] presets for the X series use the amplified controller low latency operating mode. When used along with subwoofers, it is recommended to use the subwoofers in low latency operating mode. To achieve this, create custom presets combining low latency channel sets and subwoofer channel sets.

If the subwoofers are driven from a dedicated amplified controller using a subwoofer factory preset, they are operated in normal latency mode. Therefore, an additional delay should be set to the [xx_MO] low latency channels to align them: 2.66 ms on LA8 or 3.00 ms on LA4X and LA12X.

X12 with KS21

With KS21, the X12 system contour is reinforced by 6 dB at 60 Hz and 2 dB at 100 Hz, and the system bandwidth is extended down to 31 Hz.

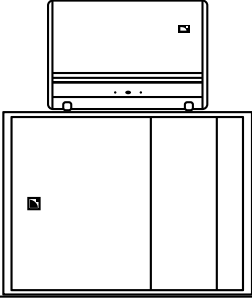
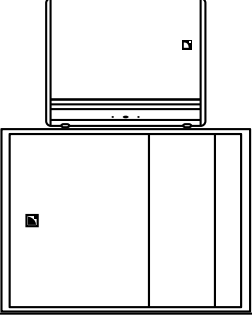

Values and ratios are the same for KS21 i.

	35°	55°
		
Enclosure	X12	KS21
Preset	[X12_MO]	[KS21_100]
Frequency range (-10 dB)	31 Hz - 20 kHz ([KS21_100])	
Enclosure ratio	1 X12 : 1 KS21	



Delay values

Do not forget to add the pre-alignment and geometric delays depending on the configuration.

Pre-alignment delays

presets	pre-alignment delay values and polarity settings	
[X12_MO] + [KS21_100]	X12 = 0 ms <input data-bbox="967 1227 1015 1279" type="button" value="+"/>	KS21 = 0.4 ms <input data-bbox="1445 1227 1493 1279" type="button" value="+"/>



[xx_MO] presets for the X series use the amplified controller low latency operating mode. When used along with subwoofers, it is recommended to use the subwoofers in low latency operating mode. To achieve this, create custom presets combining low latency channel sets and subwoofer channel sets.

If the subwoofers are driven from a dedicated amplified controller using a subwoofer factory preset, they are operated in normal latency mode. Therefore, an additional delay should be set to the [xx_MO] low latency channels to align them: 2.66 ms on LA8 or 3.00 ms on LA4X and LA12X.

Inspection and preventive maintenance

How to do preventive maintenance

Inspect the system before any deployment and after any corrective maintenance operation.

Perform preventive maintenance at least once a year.

Rigging and hardware

Perform the [Rigging part inspection](#) (p.34) on each rigging part.

Use the [Mechanical system overview](#) (p.35) to identify critical parts of the system and apply the specific checks described in the [Inspection references](#) (p.40).

If any parts are damaged, contact your L-Acoustics representative for further instructions.

Acoustics

Perform the [Enclosure check](#) (p.42).

Perform the [Listening test](#) (p.44) to detect any degradation in sound quality.

If necessary, refer to the [Corrective maintenance](#) (p.74) section for speaker repair kits and maintenance instructions.

Rigging part inspection

About this task

For critical rigging parts, use the [Inspection references](#) (p.40) for comparison and specific manipulations.

The term "rigging part" comprises:

- lifting accessories such as clamps and shackles
- rigging accessories such as rigging frames, rigging interfaces, and brackets
- fasteners used for assembling two products together such as ball-locking pins, rigging axes, rigging screws, threaded knobs, and safety pins

This inspection procedure covers only L-Acoustics products. To inspect other products that are part of the lifting chain, refer to the manufacturer's instructions.

Prerequisite

Perform the inspection in a well-lit environment.

Procedure

1. Check that the rigging part is present.
2. If applicable, disassemble the rigging part from the enclosure or the rigging accessory.

Check that the tethers are intact and safely secured.

3. Inspect the part from every side.

Compare with the **reference pictures**.

Check for:

- corrosion
- wear and cracks
- bends and dents
- holes
- missing safety cues
- missing identification labels
- missing or loose fasteners

**Replacing screws**

If a screw is loose, remove and replace it.

Always use the new screws provided in the repair kit.

If no new screw is available, add blue threadlocker before reusing the screw.

Do not apply more than the indicated torque.

4. Check the geometry of the part to identify critical deformations.

Place the rigging part on a flat surface or hold a level against it.

5. Check the moving parts.

Make sure that the mechanism engages correctly.



What to do next

If a problem is detected, perform the authorized maintenance operations or contact your L-Acoustics representative.

Mechanical system overview

Critical parts of the lifting chains are highlighted.



The  indicates a visual inspection. The  indicates a functional check.



 Perform the [Rigging part inspection](#) (p.34) on critical parts.

For each part, refer to the [Inspection references](#) (p.40).

**Replacing screws**

If a screw is loose, remove and replace it.

Always use the new screws provided in the repair kit.

If no new screw is available, add blue threadlocker before reusing the screw.

Do not apply more than the indicated torque.

**Hi-Fi
POWER**

X12 with X-UL12

the supporting screws are tightened

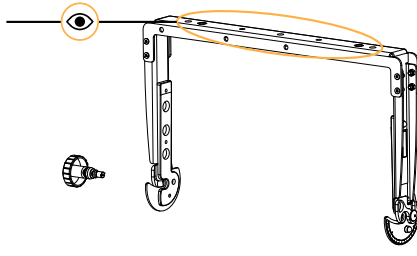

Threaded knobs (p.40)

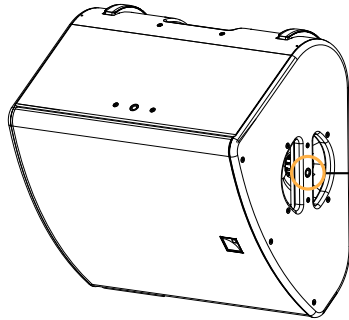

the inserts are not damaged

X12 with X-US1215 and X-UTILT

the inserts are not damaged

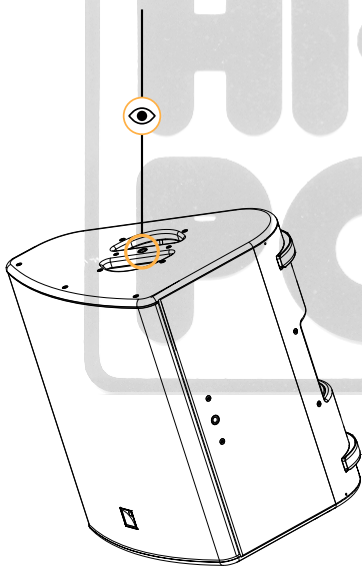

Threaded knobs (p.40)

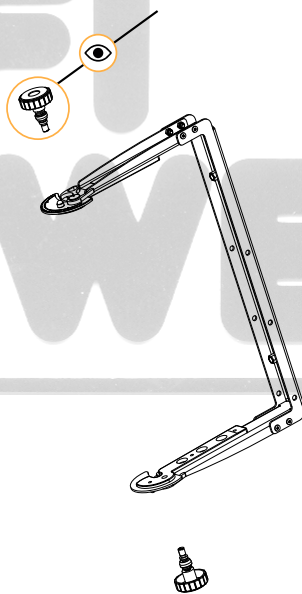

the supporting screws are tightened

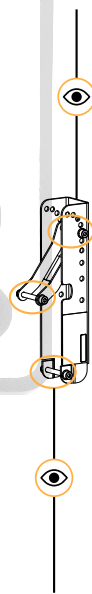

the axes are tightened and not bent

X12 with X-BAR and CLAMP250

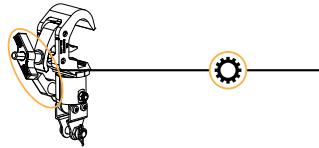

the wing knobs can be tightened and loosened by hand

pull up the lever and release it:
the lever returns to its initial position

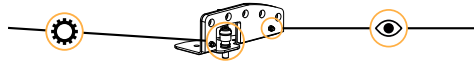

all screws are tightened

the top inserts are not damaged

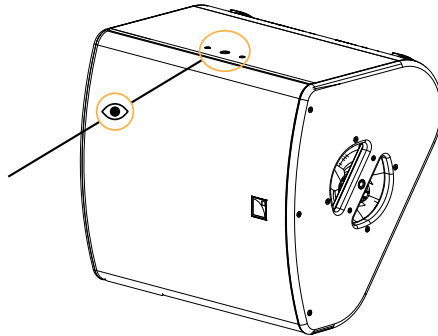

X12 pole-mounted

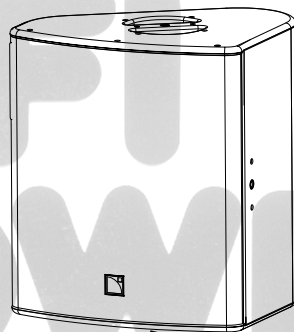

the pole-socket is not damaged

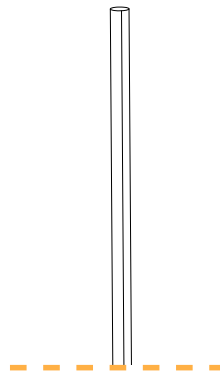
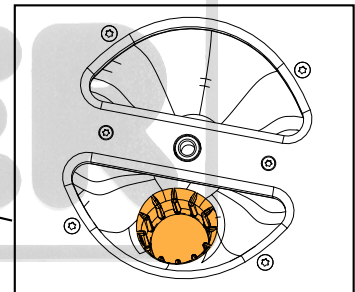

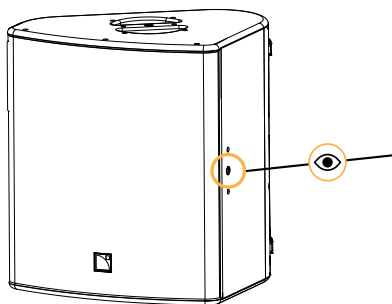

X12 pole-mounted with X-US1215 and EMBi on SB18

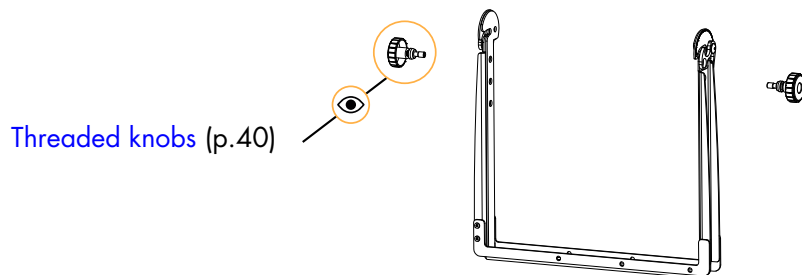

the inserts are not damaged



Threaded knobs (p.40)

the screws are tightened   the wing knob is tightened

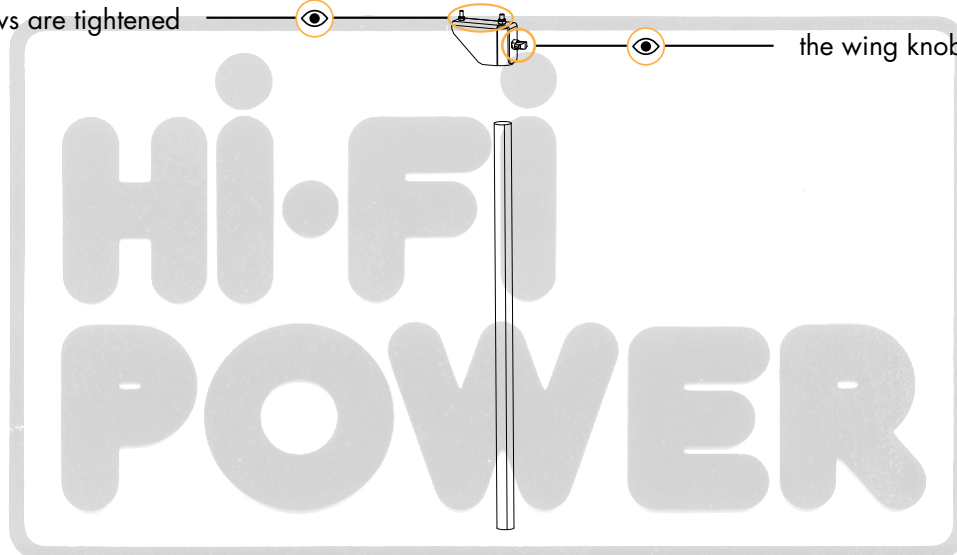

Pole-mount socket (p.41)

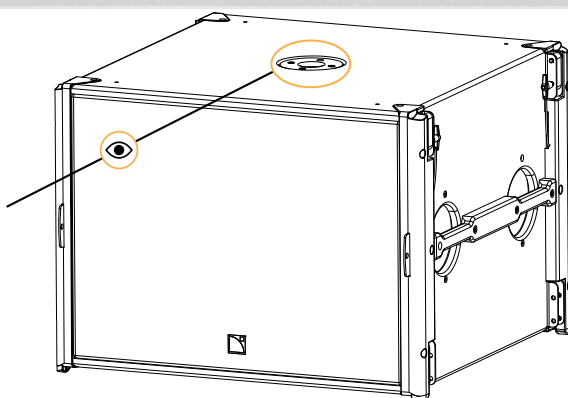

X12 on the ground

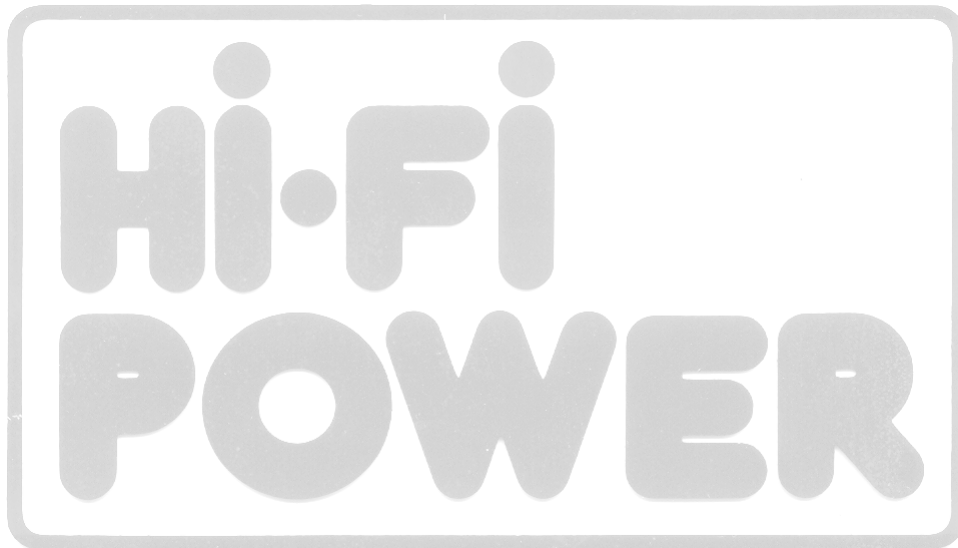
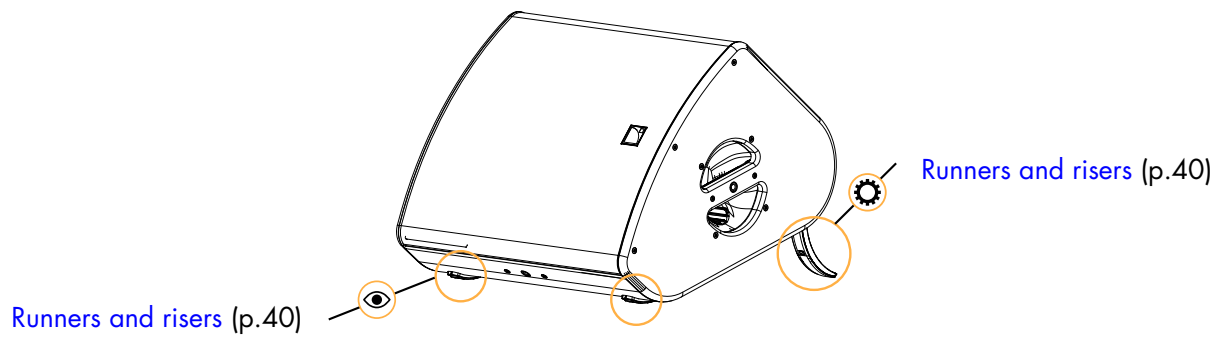

Inspection references

Threaded knobs

- Head part does not have cracks.
- Head part is tightly secured to the body part.
- All washers are present.

Reference pictures

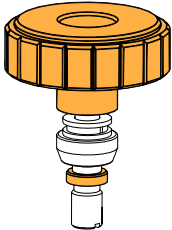

Related tasks

[Rigging part inspection](#) (p.34)

Runners and risers

- Runners are not worn out.
- Risers are not damaged and move correctly.
- Screws are tightened.

Reference pictures

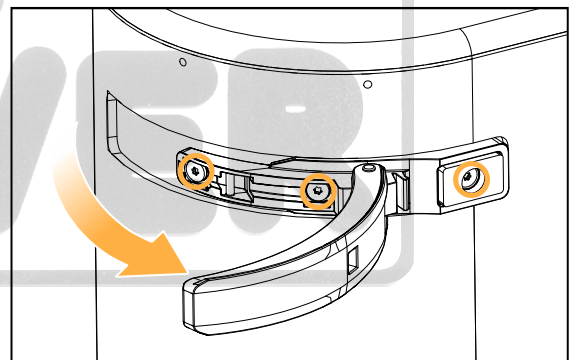
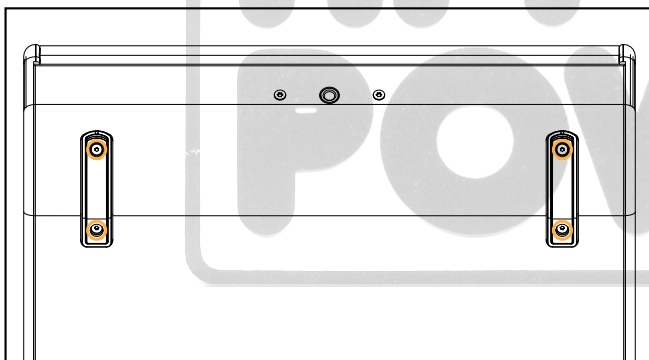

! Contact your L-Acoustics representative for repair instructions.

Related tasks

[Rigging part inspection](#) (p.34)

Pole-mount socket

- Pole-mount socket is not damaged or bent.
- Screws are tightened.
- Socket plug is present.

Reference pictures

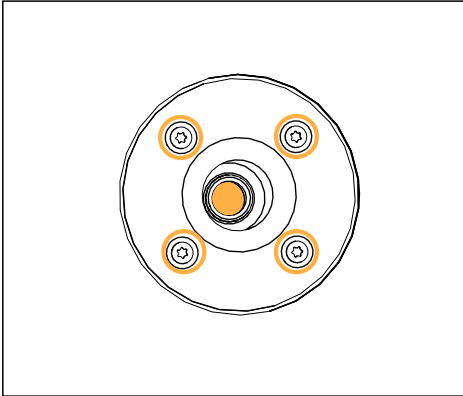

Contact your L-Acoustics representative for repair instructions.

Related tasks

[Rigging part inspection](#) (p.34)

Hi-Fi
POWER

Acoustical check

Enclosure check



This feature is available on:

LA4X
LA12X

ENCLOSURE CHECK measures impedance at the reference frequencies for the connected loudspeaker family. The measured impedance is compared to the expected range allowing for fast detection of loudspeakers presenting circuit continuity issues.



The results can be used for preliminary diagnosis but cannot replace a comprehensive quality control.

Prerequisite



ENCLOSURE CHECK measurements can only be reliable if the following requirements are met:

Environment and temperature:

- Ambient temperature must be comprised between 0 °C / 32 °F and 40 °C / 104 °F. Ideal temperature is 20 °C / 68 °F.
- Enclosures must be at room temperature. If warm from a recent high level use or recently moved from a cold environment, let the loudspeakers reach room temperature before starting.

Enclosures:

- Enclosures must be included in the embedded factory preset library.
- Enclosures must be in nominal operating conditions:
 - Remove covers or dollies obstructing the loudspeakers or the vents.
 - Check for obvious physical damage or air leak: visually inspect the grill, gasket, cabinet, and connector plate for loose, missing or damaged parts.

Connection:

- Use only 10 m / 30 ft 4 mm² / AWG 11 speaker cables.
- Do not connect enclosures in parallel.

Amplified controllers:

- LA4X must run at least firmware version 1.1.0.
- LA4X load sensors must be calibrated. Refer to the **Load Sensor Calibration Tool** technical bulletin for more information.
- LA4X must warm up for at least 10 minutes after power up. Do not power off, reboot or switch to standby mode to avoid resetting the countdown.
- Load a preset corresponding to the connected loudspeaker's family. Presets from the user memories may be used on condition they are made of presets supported in the embedded factory preset library.

Procedure

1. Power up the amplified controller. Let LA4X warm up for at least 10 minutes.
2. Connect the loudspeaker enclosures to the amplified controller.
3. Load a preset from or built from the embedded library corresponding to the connected loudspeaker family.
4. On the amplified controller, use the encoder wheel to select **MONITORING & INFO**. Press the OK key or the encoder wheel to validate.
5. Use the encoder wheel to select **ENCLOSURE CHECK**.



Beware of sound levels.

Although the sound pressure levels generated for the ENCLOSURE CHECK are moderate, do not stay within close proximity of the loudspeakers and consider wearing ear protection.

6. Press the OK key or the encoder wheel to launch the ENCLOSURE CHECK.

The amplified controller generates short sinusoidal signals simultaneously for each connected output.

The amplified controller displays the results for each output.

7. Depending on the displayed results, follow the instructions in the table.

result	interpretation	instructions
OK	measured impedance is within expected range	enclosure is in working order electrically
?	unsupported preset family	only supported enclosures should be tested
NC	Not Connected	if cables are connected: a. inspect the cables and connections b. go to step 8 (p.43)
NOK	measured impedance is not within expected range	a. check that all the prerequisites are met, in particular that the loaded preset corresponds to the connected speaker's family b. inspect the cables and connections c. go to step 8 (p.43)
UNDEF	measured impedance is undefined	

8. Under NC, NOK and UNDEF results, press and hold the corresponding OUT key.

The amplified controller displays:

- the tested frequencies,
- information on the measured impedance:
 - OPEN for open circuit (found in NC results),
 - SHORT for short circuit (found in NOK results), or
 - a percentage of variation from the expected range (found in NOK and UNDEF results)
- the number of operational transducers out of the total

i Low variations from the expected range are acceptable: displayed percentage can be different from 0 and all transducers considered operational.

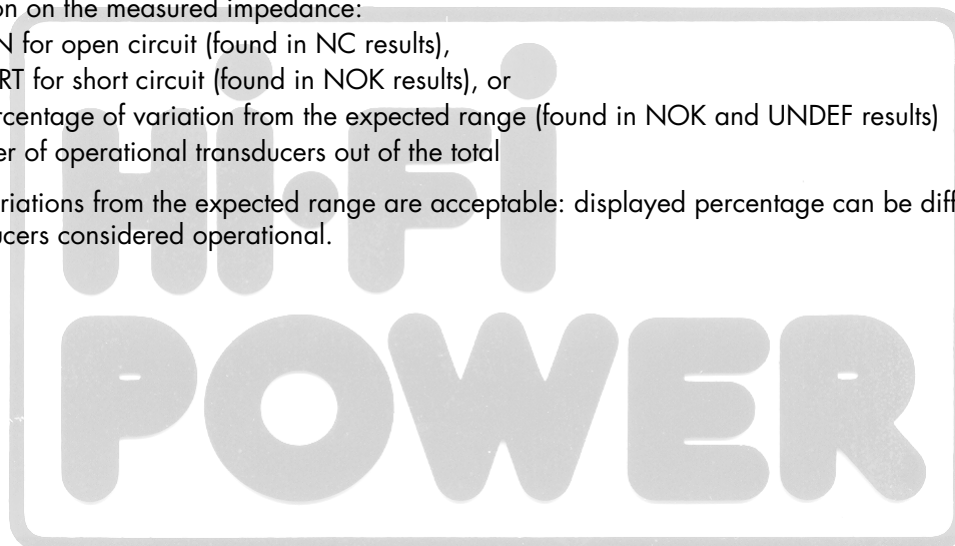

Listening test

enclosure	preset	usable bandwidth
X12	[X12]	59 Hz - 20 kHz

Procedure

1. Load the preset on an LA4X / LA8 / LA12X amplified controller.
2. Connect a sinus generator to the amplified controller.



Risk of hearing damage

Set a low sound level to start and use ear protection to adjust before testing.

3. Scan the bandwidth focusing on the usable range.
The sound should remain pure and free of unwanted noise.

Troubleshooting for LF speakers

One or more LF speaker produces distorted, buzzing, rubbing, clicking, muffled or weak sound.

Possible causes

- The screws are not tightened with the appropriate torque.
- There is an air leak in the gasket.
- There is dust on the cone.
- The cone is damaged.
- The surround is torn or delaminated.
- The voice coil or the spider is damaged.

Procedure

1. Perform the speaker disassembly procedure.
2. Visually inspect the cables and the connectors.
3. Visually inspect the speaker cone, the voice coil and the spider.

If any damage is visible, replace the speaker.

4. Carefully clean the speaker with a dry cloth.
5. Perform the reassembly procedure.
Replace the speaker gasket and the screws.
Apply the recommended torque.

6. Repeat the listening test.

If the problem persists, replace the speaker.

Troubleshooting for HF drivers

One or more HF driver produces high-frequency harmonic distortions, strange vibrations or weak sound.

Possible causes

- There are foreign particles on the air gap.
- The diaphragm is not centered correctly.
- The screws used for reassembly are too loose.
- The diaphragm is damaged.
- The number of shims is wrong.

Procedure

1. Perform the diaphragm disassembly procedure.
2. Visually inspect the diaphragm and the voice coil.
If any damage is visible, replace the diaphragm.
3. Clean the air gap thoroughly.
Use double-face adhesive tape to remove any particles.
4. Perform the diaphragm reassembly procedure.
Pay close attention to the number of shims and the position of the diaphragm.
Apply the recommended torque.
5. Repeat the listening test.



If a buzzing sound is still audible, it might be necessary to add an extra shim on the air gap.

If the problem persists, replace the driver.

HI-FI
POWER

Rigging procedures

Wall-mounting and ceiling-mounting

Mounting on X-US1215 or X-UL12

type of deployment	wall-mounting
	ceiling-mounting
rigging accessories	X-US1215 or X-UL12
additional material	3 × M10 screws and anchors
	electric screwdriver
min number of operators	1 or 2

! Additional safety for flown arrays
When flying an enclosure, use the M8 DIN580 threaded insert to implement a secondary safety.

! Ceiling-mounting
Additional holes on the short U-bracket can be used for optimal visual impact.
In this case, the rigging procedure will require 2 operators.

! Short U-bracket in horizontal position
In this position, the enclosure applies a diagonal force of **405 daN** on the anchoring points.

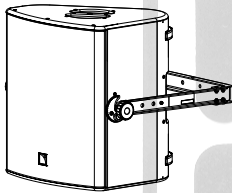

! Fasteners for wall-mounting or ceiling-mounting
Secure the bracket with three M10 screws.
Select screw length and anchors applicable to the wall or ceiling properties.

! When wall-mounting X12 horizontally with X-US1215, it is recommended to mount the enclosure with the logo on the left. In this position, the cabinet is resting on the bracket's gasket, which prevents the enclosure from rotating.

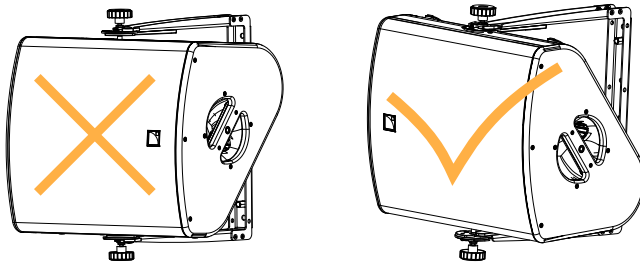

i The procedure is shown with X-UL12 in horizontal position.
The same procedure applies for X-UL12 in vertical position or in ceiling-mounting configuration and X-US1215 in horizontal or vertical position or in ceiling-mounting configuration.

Assembly

Procedure

1. Drive the knobs in the inserts on the enclosure.
Stop when the threading is halfway in.

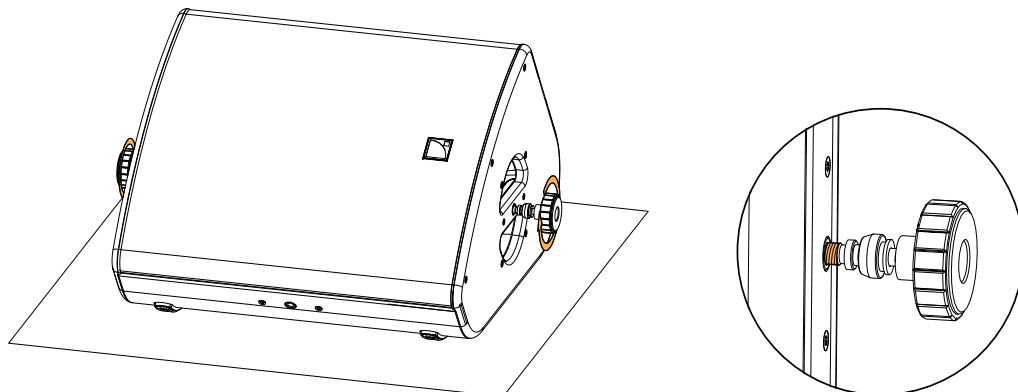

! When securing the U-bracket horizontally, make sure the hooks are oriented upwards.

! **Fasteners for wall-mounting or ceiling-mounting**
Secure the bracket with three M10 screws.
Select screw length and anchors applicable to the wall or ceiling properties.

2. Secure the U-bracket to the wall using M10 screws.

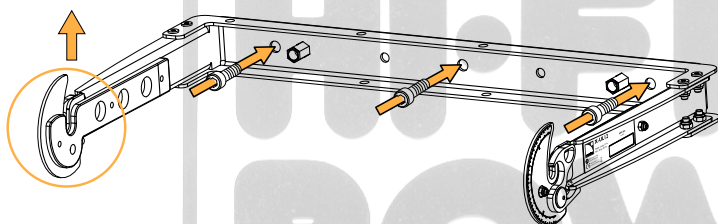

3. Lift the enclosure by the knobs and place it inside the U-bracket.
Adjust the knobs on both sides so that the safety washer is between the hook and the enclosure.

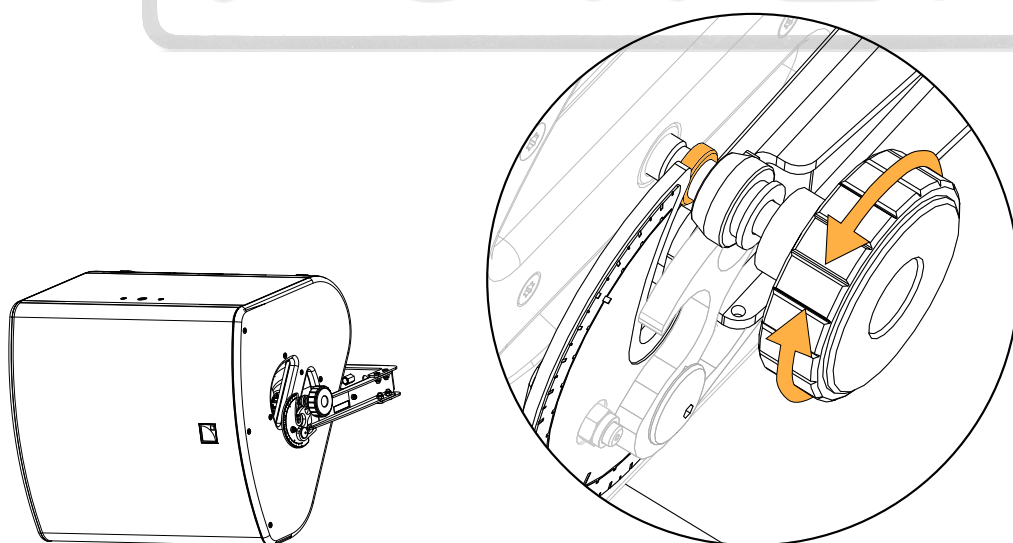

4. Push until the knobs are locked inside the spring-lock safety mechanism.

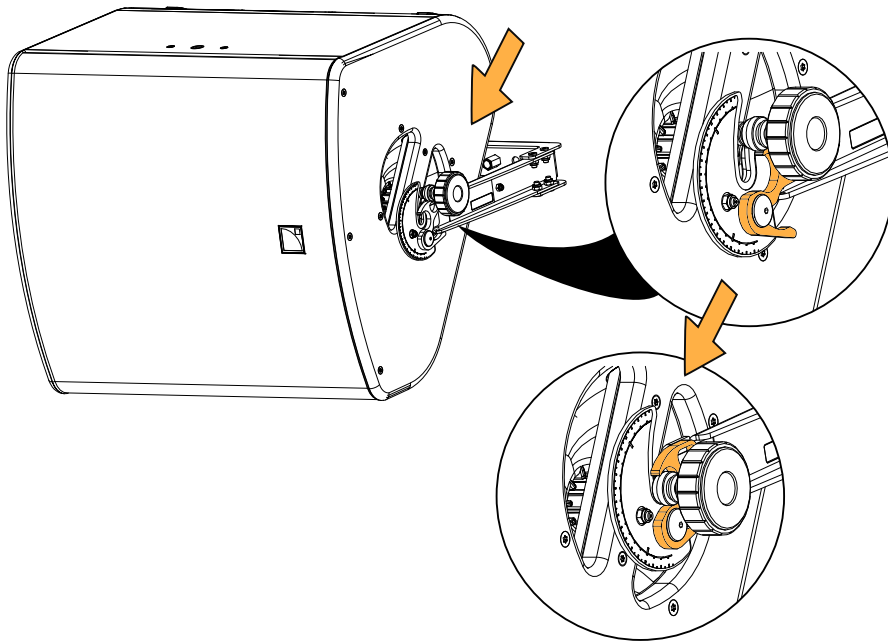

SHLAK!

5. Set the site angle.

Use the screw as a reference point to read the label.

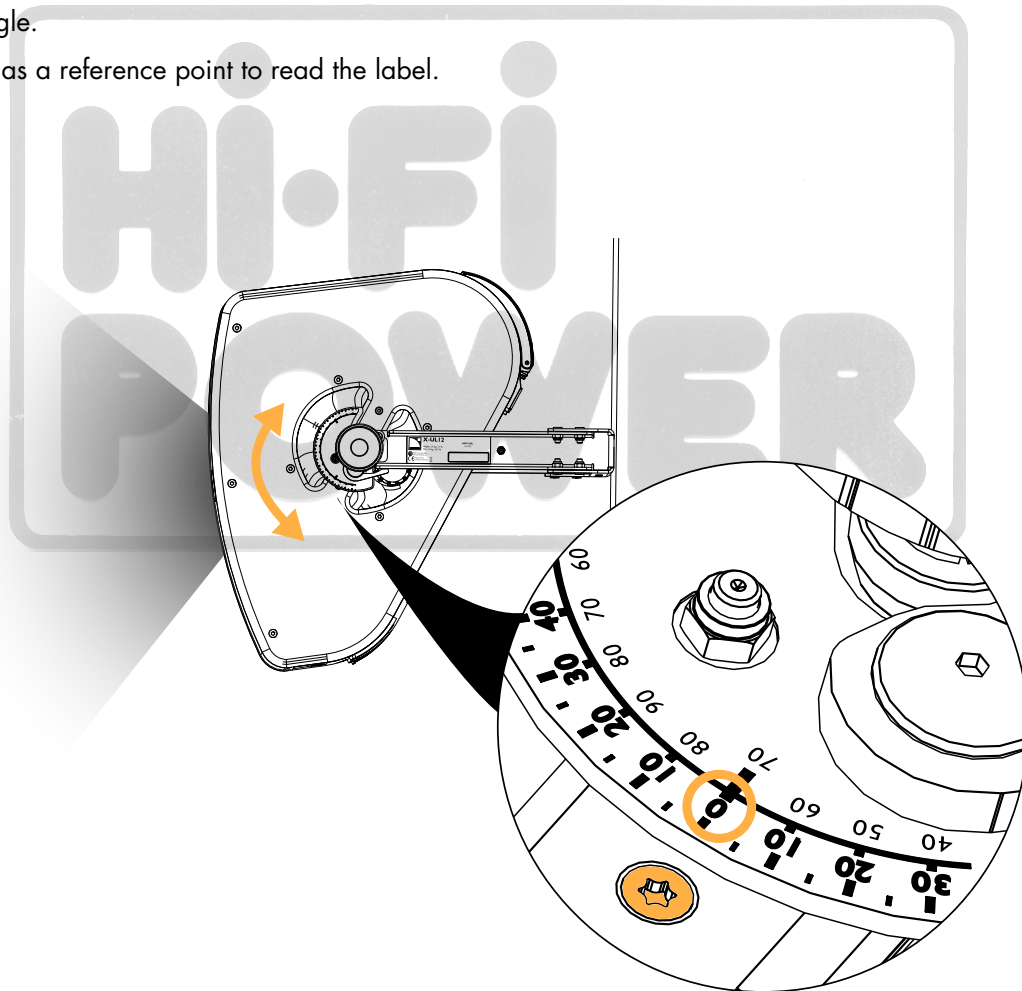

6. Tighten the knobs.

Make sure the enclosure is steady.

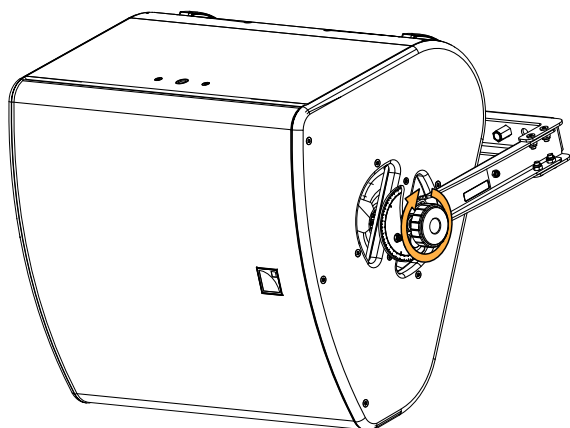
**Disassembly****Procedure**

1. Loosen the knobs until the enclosure can rotate freely.



Do not unscrew the knobs all the way.

2. On both sides, pull on the safety mechanism while lifting the enclosure by the knobs to release it.

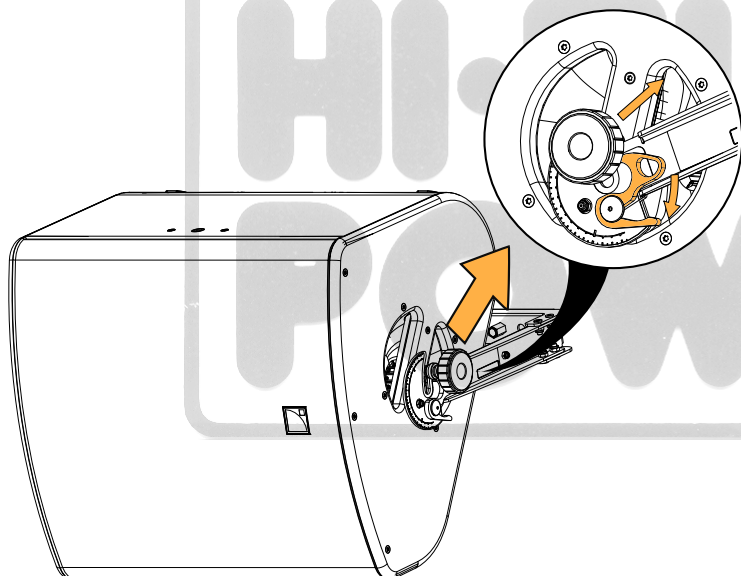

3. Remove the U-bracket from the wall.

Using X-US1215 or X-UL12 with X-UTILT

type of deployment	wall-mounting
rigging accessories	X-US1215 or X-UL12
	X-UTILT
additional material	2 x M10 screws
	electric screwdriver
min number of operators	1

! Additional safety for flown arrays
When flying an enclosure, use the M8 DIN580 threaded insert to implement a secondary safety.

! X-UTILT intended use
Use X-UTILT only vertically and for negative site angles.

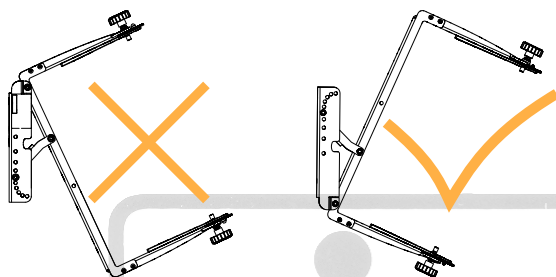

! Fasteners for wall-mounting
Secure X-UTILT with two M10 screws.
Select screw length and anchors applicable to the wall properties.

i The procedure is shown with X-UL12
The same procedure applies for X-US1215.

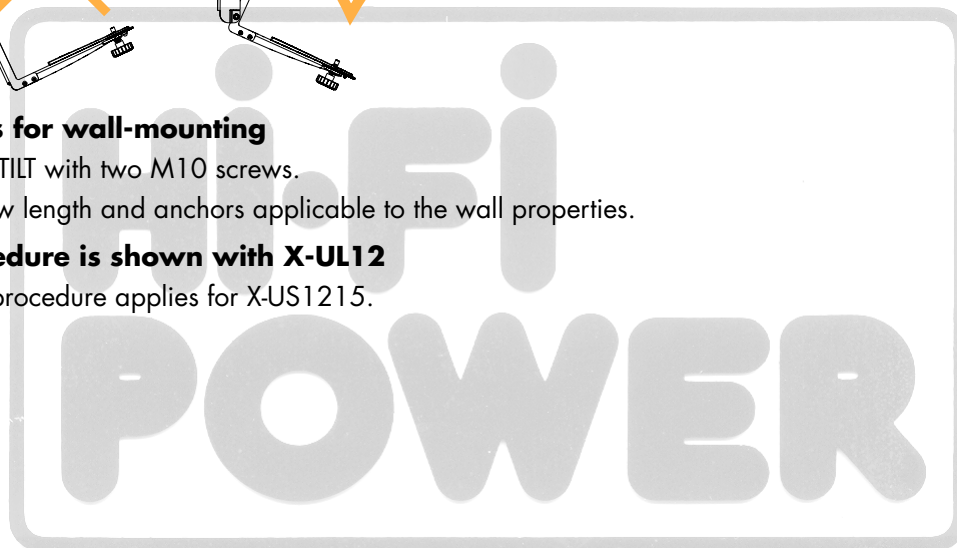

Assembly

Procedure

1. Secure X-UTILT to the wall using M10 screws.

Position X-UTILT with the holes for angle selection at the top.

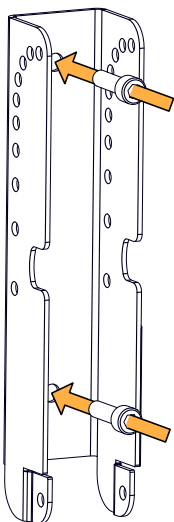

2. Secure the U-bracket to X-UTILT.

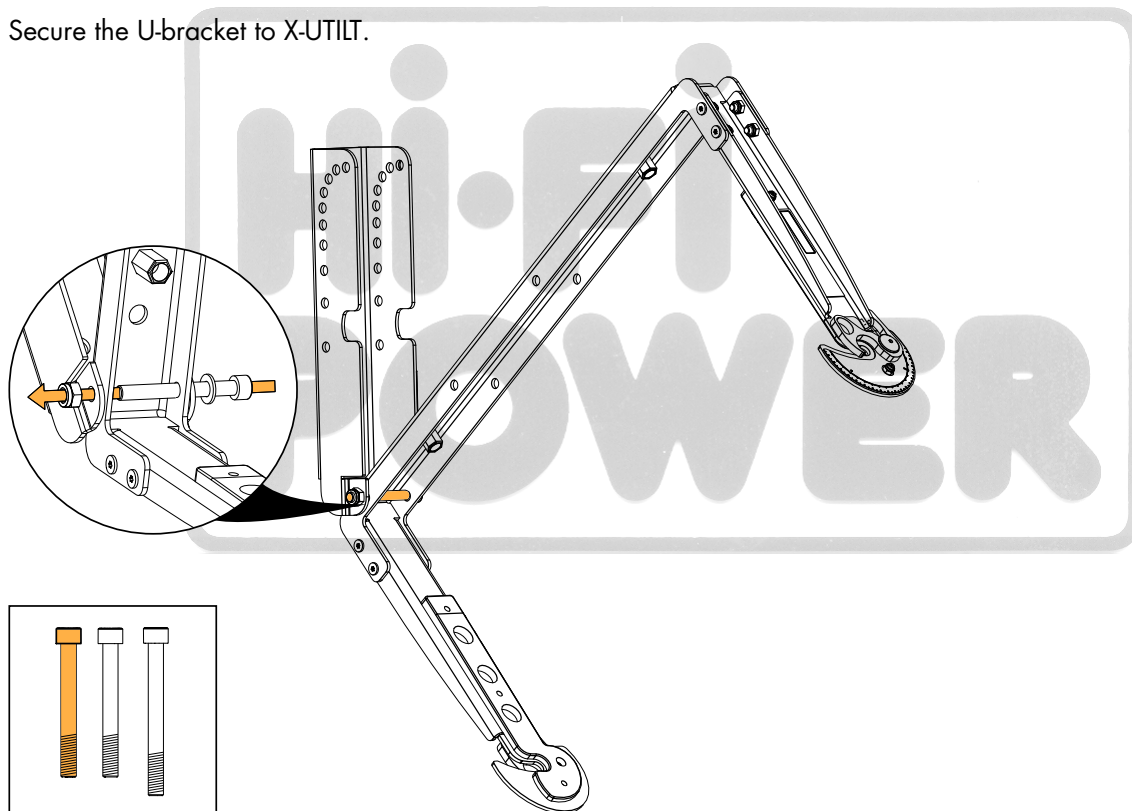

3. Secure the rigging arm to the U-bracket.

! Make sure the rigging arm is in the correct position.

! **Assembling X-UTILT with X-US1215 or X-UL12**

X-US1215 and X-UL12 have three holes for assembling with X-UTILT. Use hole 1 (furthest from the label) to secure the U-bracket to X-UTILT, and hole 2 to secure the rigging arm. Hole 3 is reserved for storage (0° site angle).

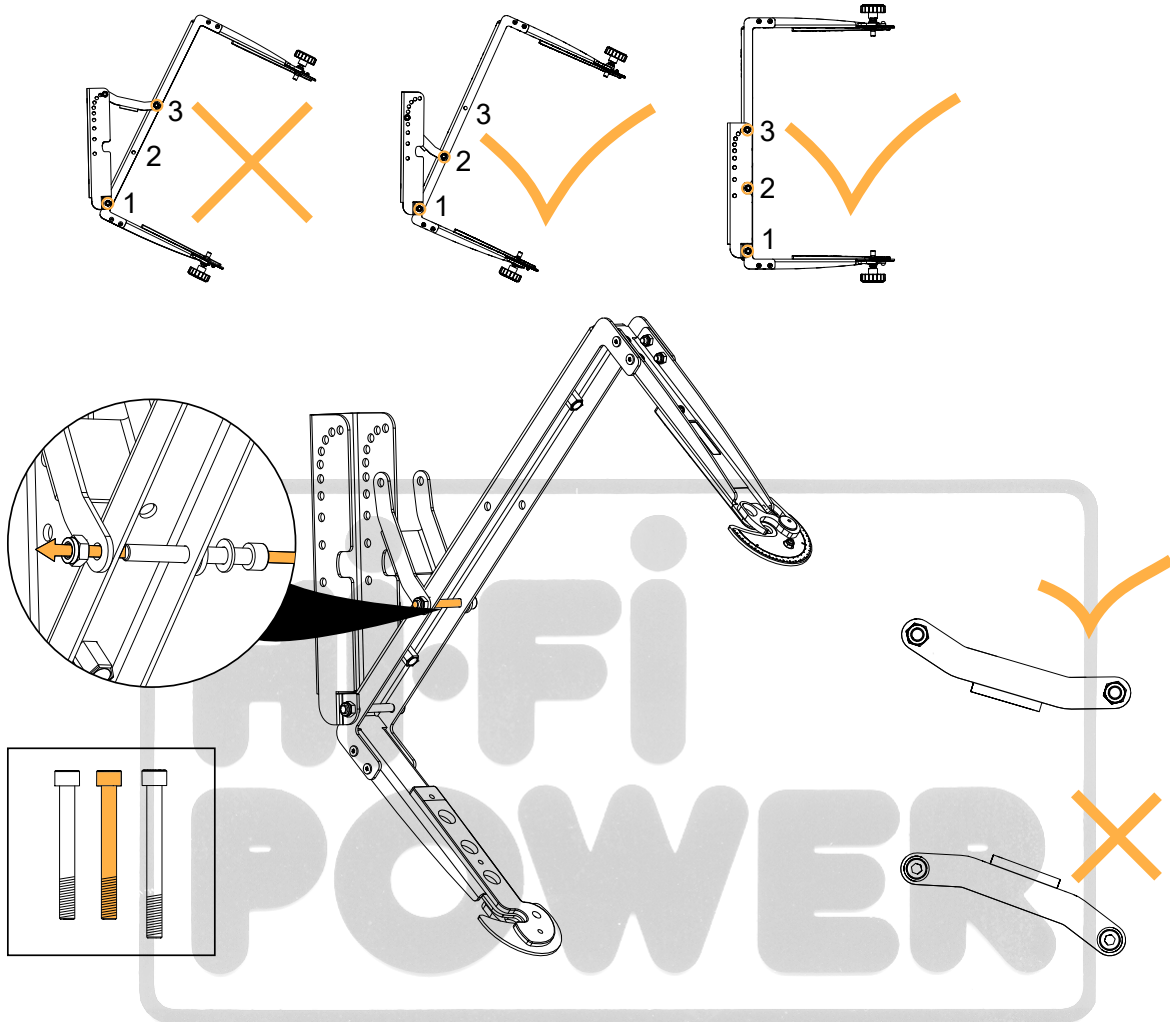

4. Choose the site angle and secure the rigging arm to X-UTILT.

Refer to the angles on the label.

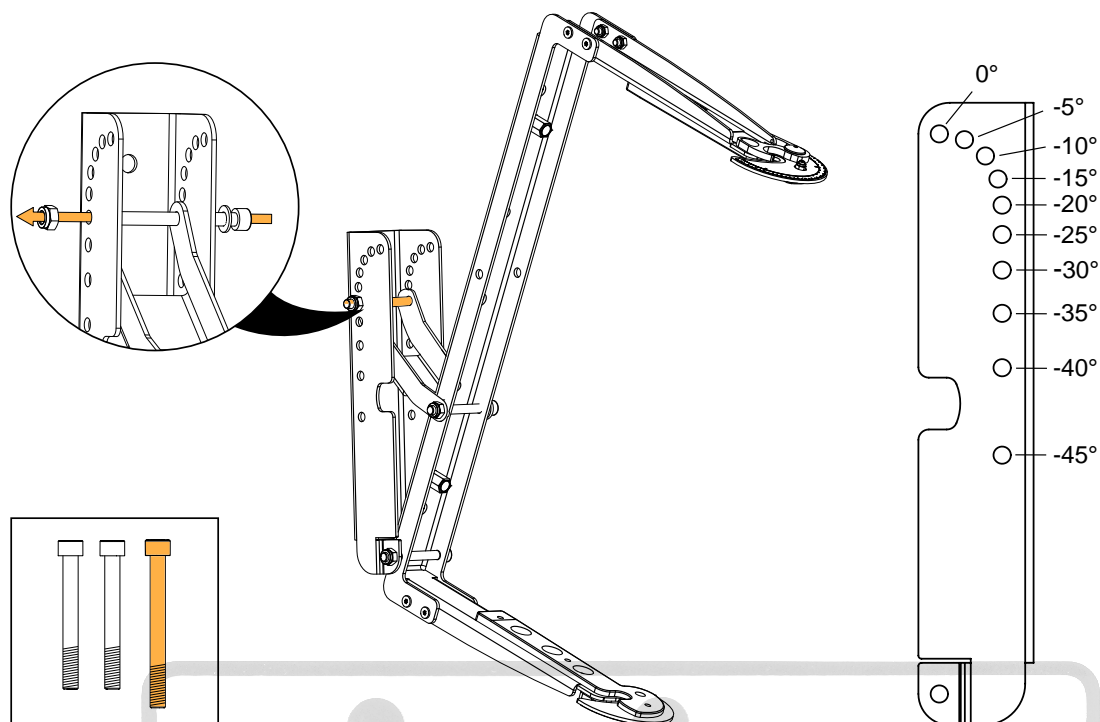

5. Drive the knobs in the inserts on the enclosure.

Stop when the threading is halfway in.

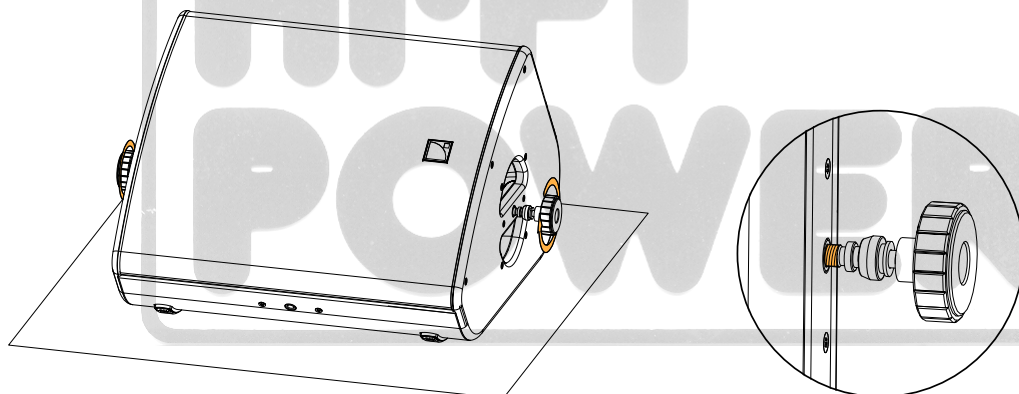

- Lift the enclosure by the knobs and place it inside the U-bracket.

Adjust the knobs on both sides so that the safety washer is between the hook and the enclosure.

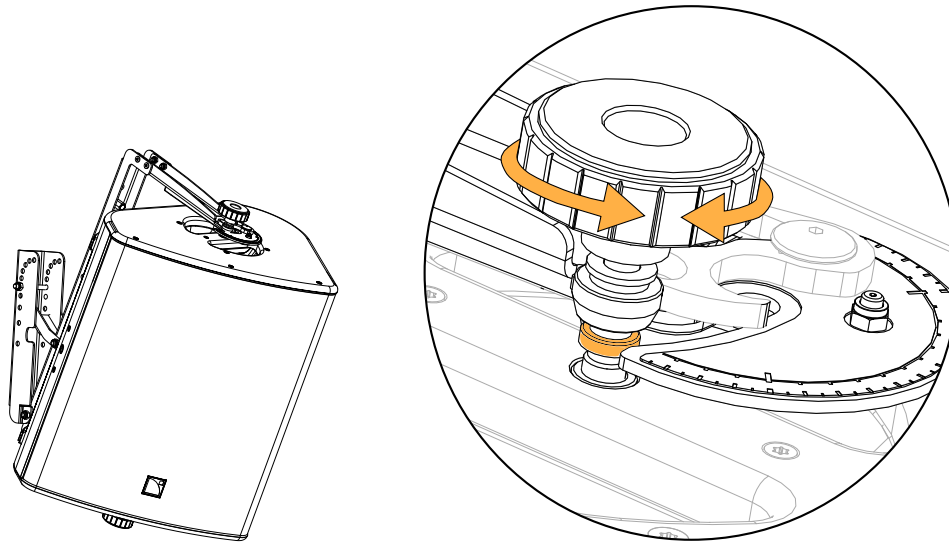

- Push until the knobs are locked inside the spring-lock safety mechanism.

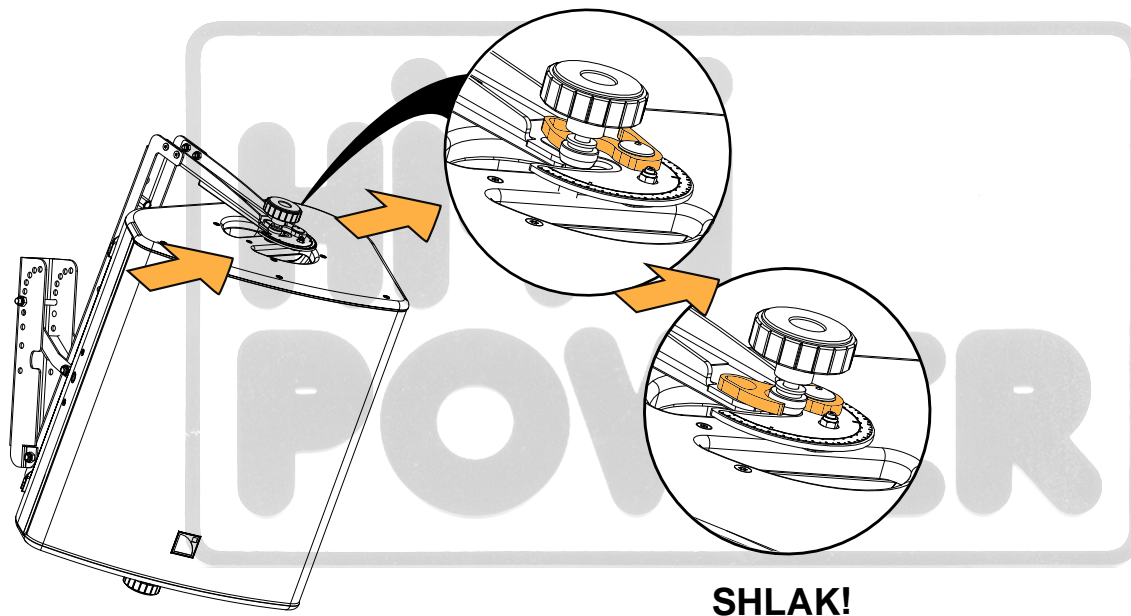

8. Set the azimuth angle.

Use the screw as a reference point to read the label.

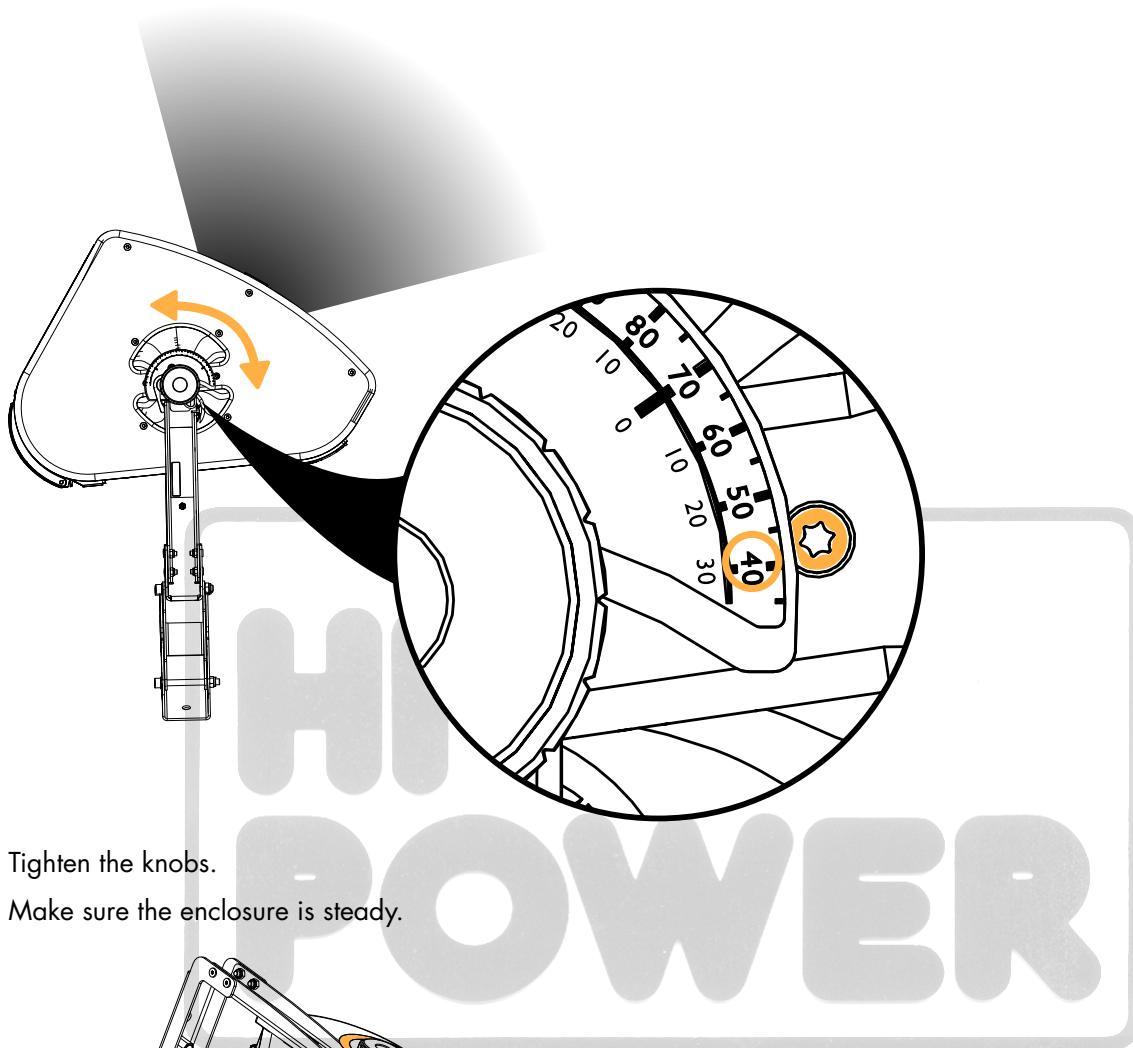

9. Tighten the knobs.

Make sure the enclosure is steady.

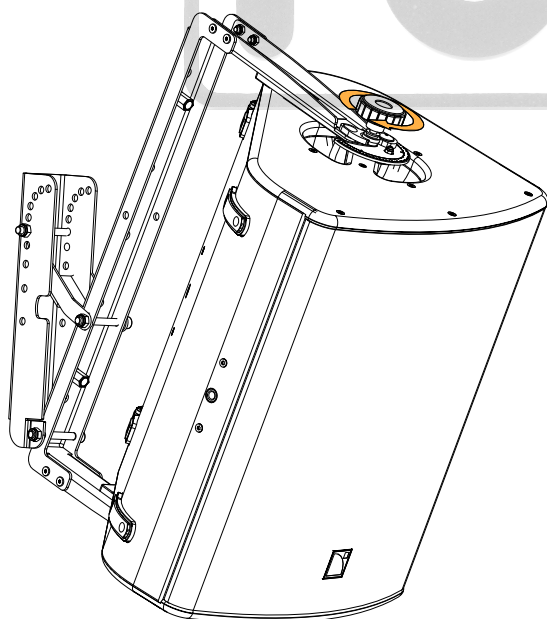

Disassembly

Procedure

1. Loosen the knobs until the enclosure can rotate freely.



Do not unscrew the knobs all the way.

2. On both sides, pull on the safety mechanism while sliding the enclosure out of the U-bracket.

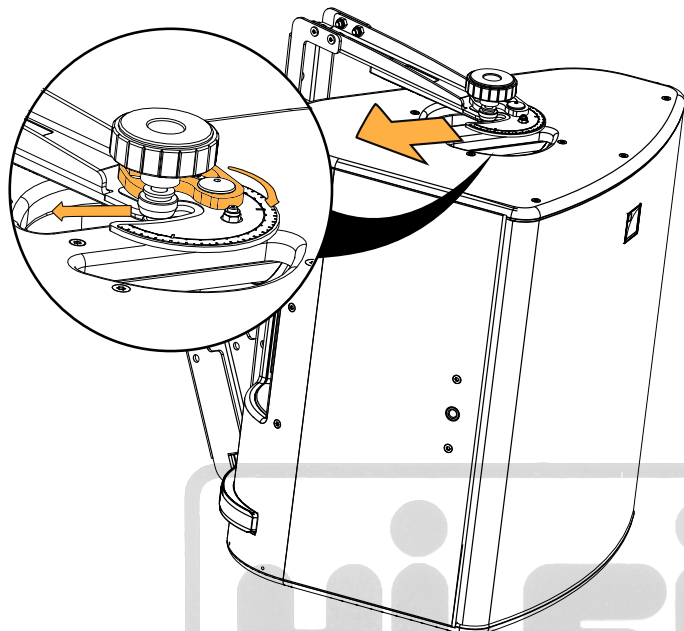

3. Remove the U-bracket and X-UTILT from the wall.

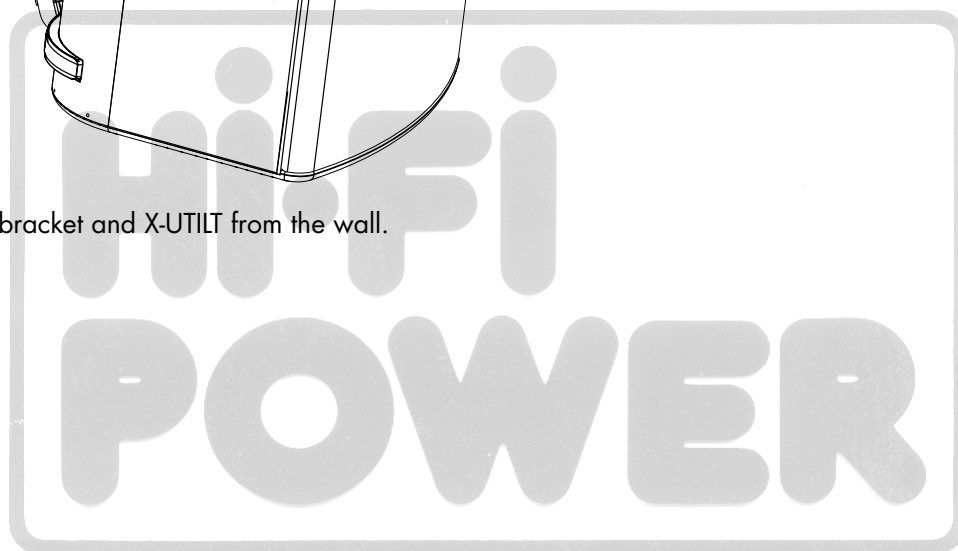

Flying

Flying with X-US1215 or X-UL12

type of deployment	flying
rigging accessories	X-US1215 or X-UL12
additional material	M10 (3/8") truss clamp
min number of operators	1

! **Additional safety for flown arrays**
When flying an enclosure, use the M8 DIN580 threaded insert to implement a secondary safety.

i **The procedure is shown with X-US1215.**
The same procedure applies for X-UL12.

Assembly

Procedure

1. Drive the knobs in the inserts on the enclosure.

Stop when the threading is halfway in.

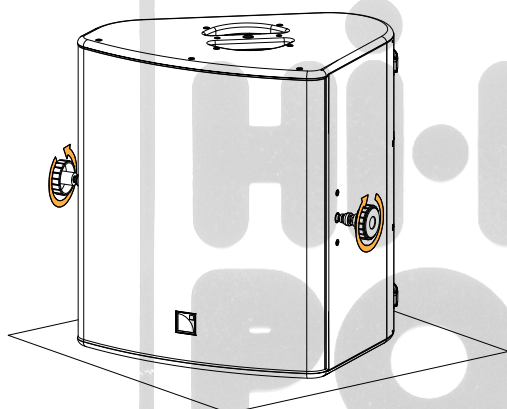

2. Place the U-bracket around the assembly.

Adjust the knobs on both sides so that the safety washer is between the hook and the enclosure.

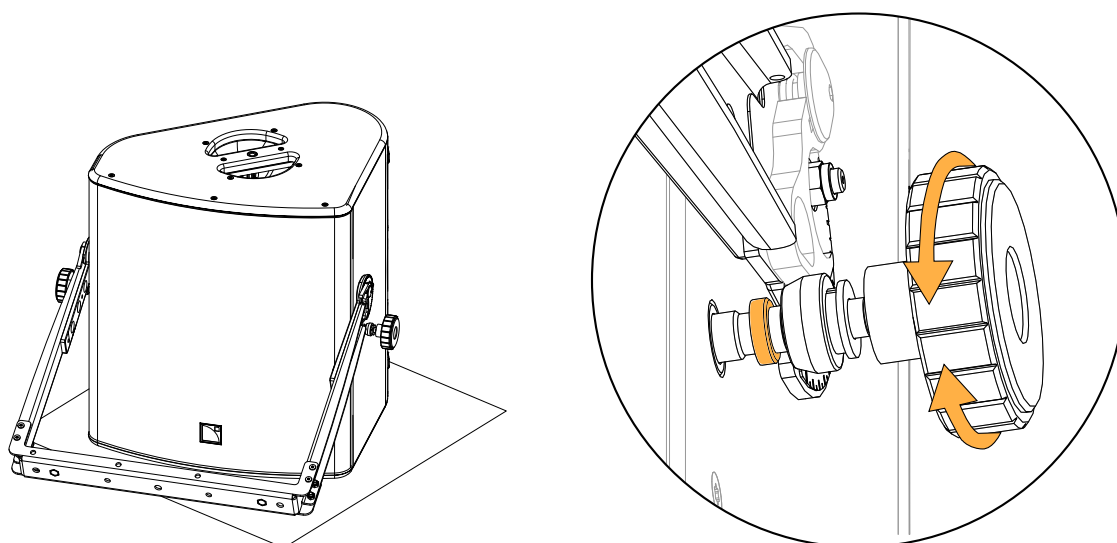

3. Push down until the knobs are locked inside the spring-lock mechanism.

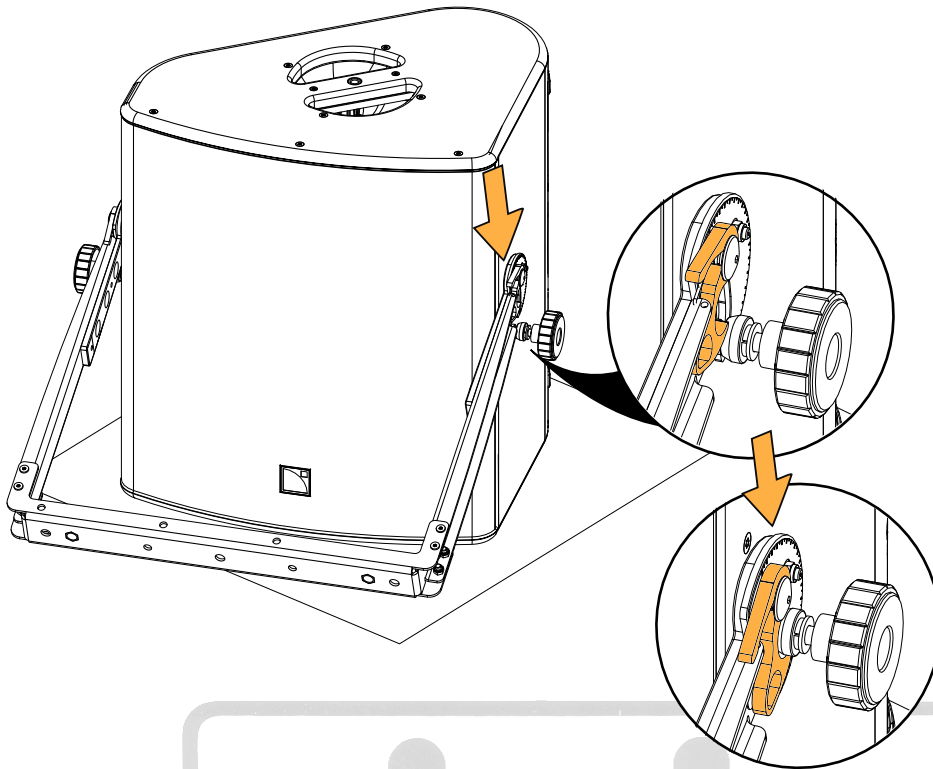

SHLAK!

Alternatively, use the additional holes on the U-bracket.



The hooks on the bracket must be oriented towards the front of the enclosure.

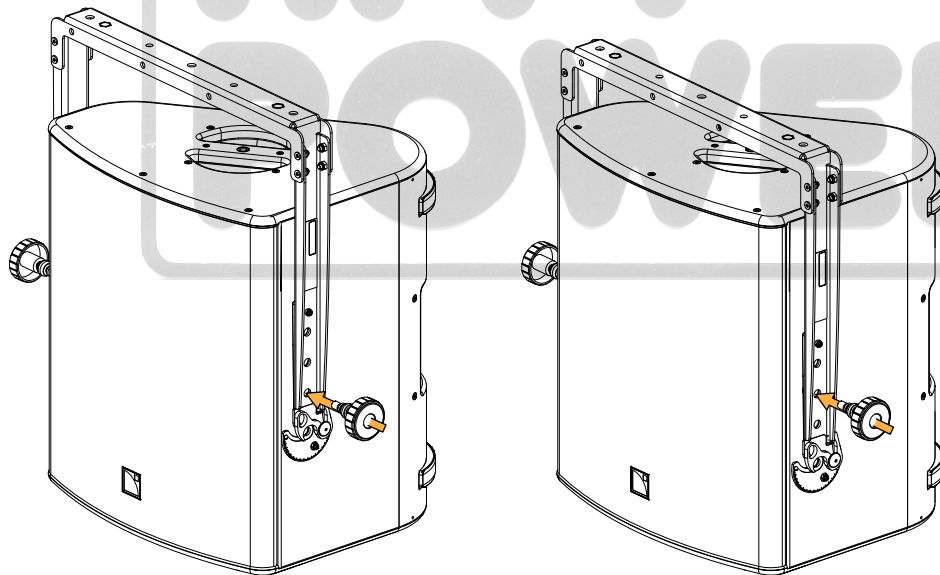

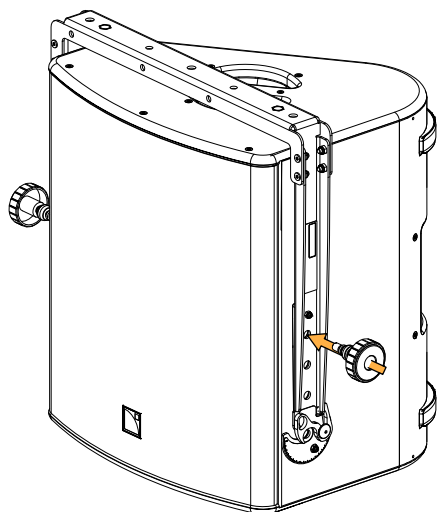

Make sure the safety washer goes through the hole on the bracket.

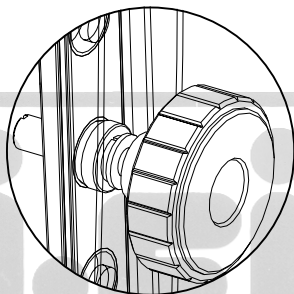
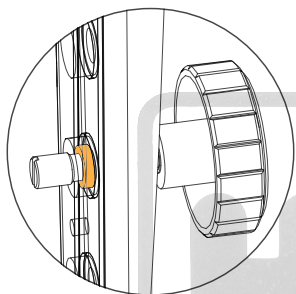

4. Tighten the knobs and fly the enclosure with a clamp.

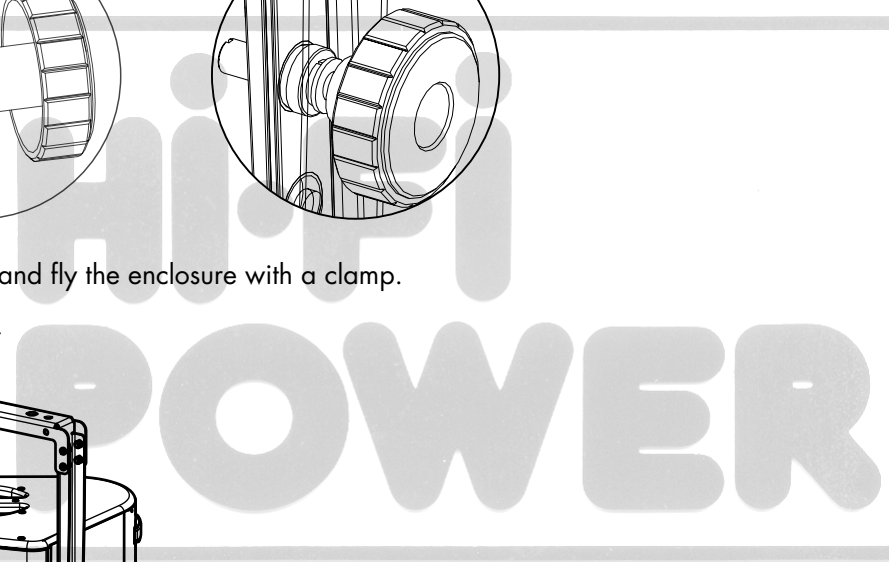
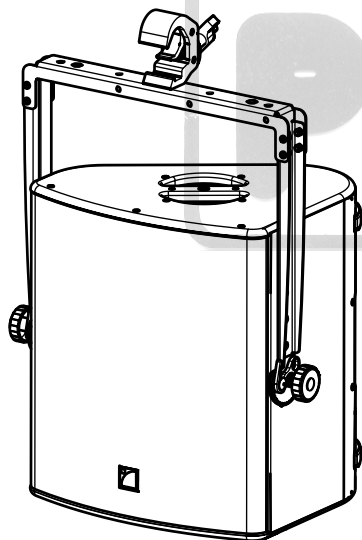

5. Loosen the knobs to set the site angle.

Use the screw as a reference point to read the label.

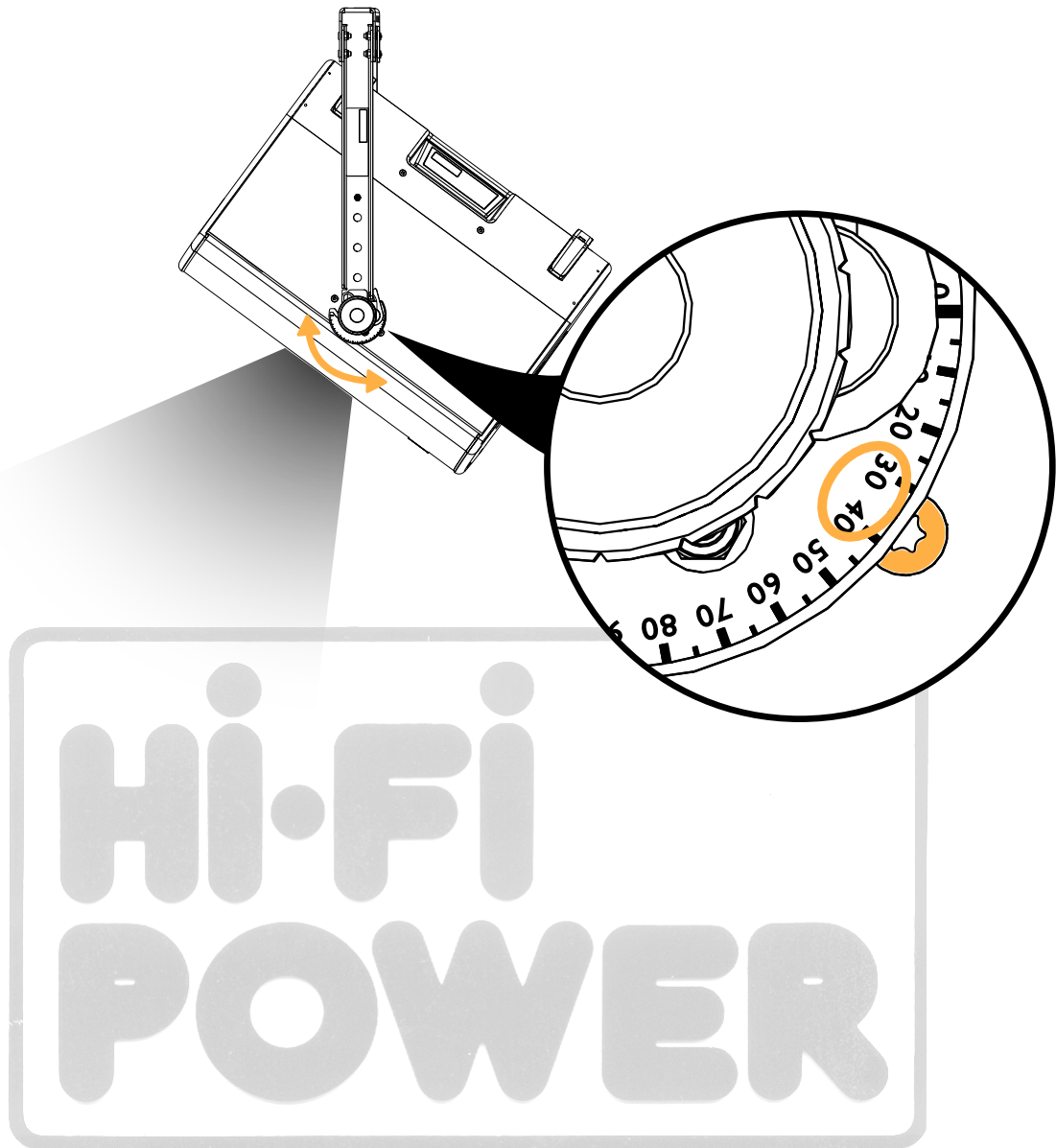

**Hi-Fi
POWER**

6. Tighten the knobs.

Make sure the enclosure is steady.

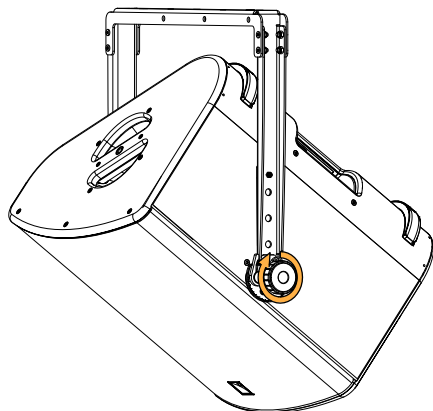

Maximum angles

When using the additional holes on the U-bracket, consider the maximum negative site angle available.

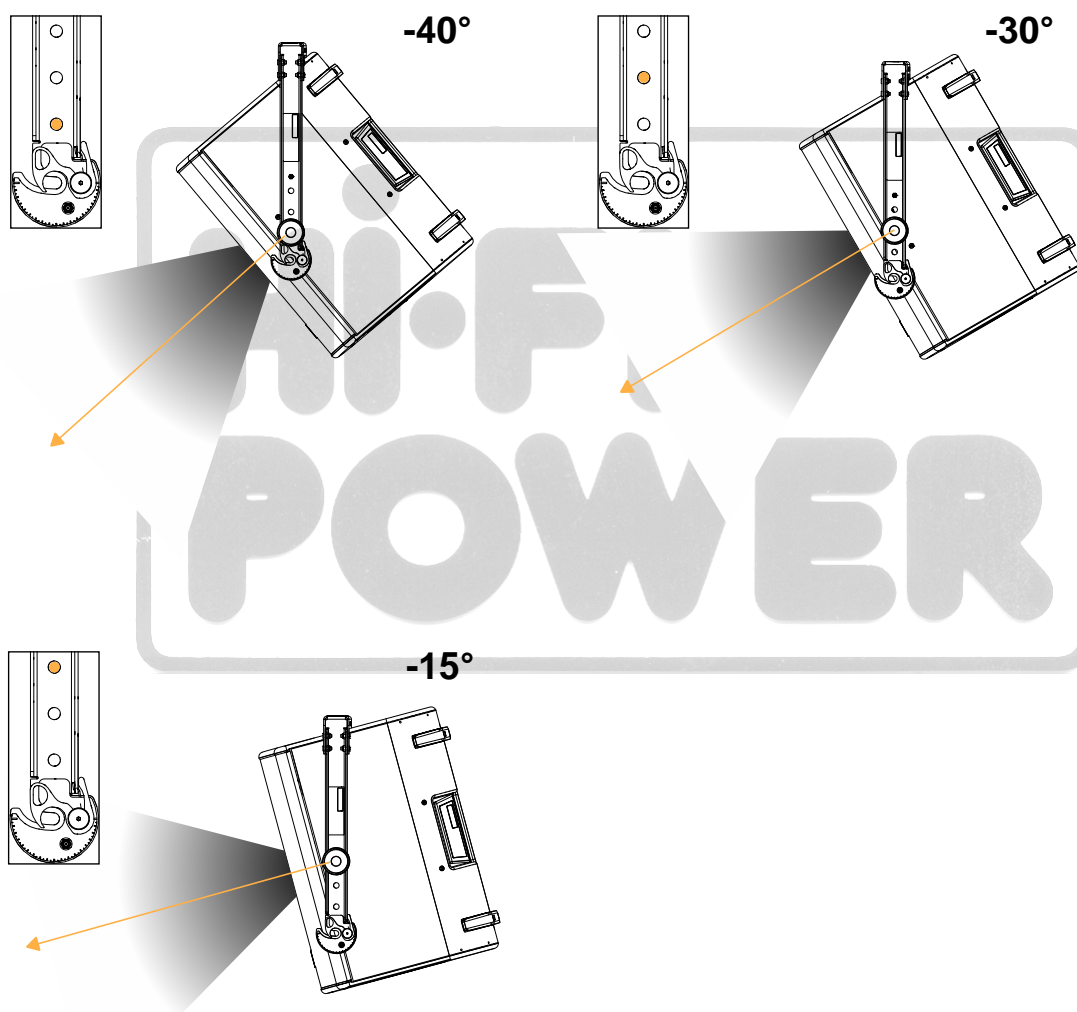

Disassembly

Procedure

1. Place the enclosure on a flat surface.
2. Loosen the knobs.
3. Pull on the safety mechanism and remove the U-bracket from the enclosure.

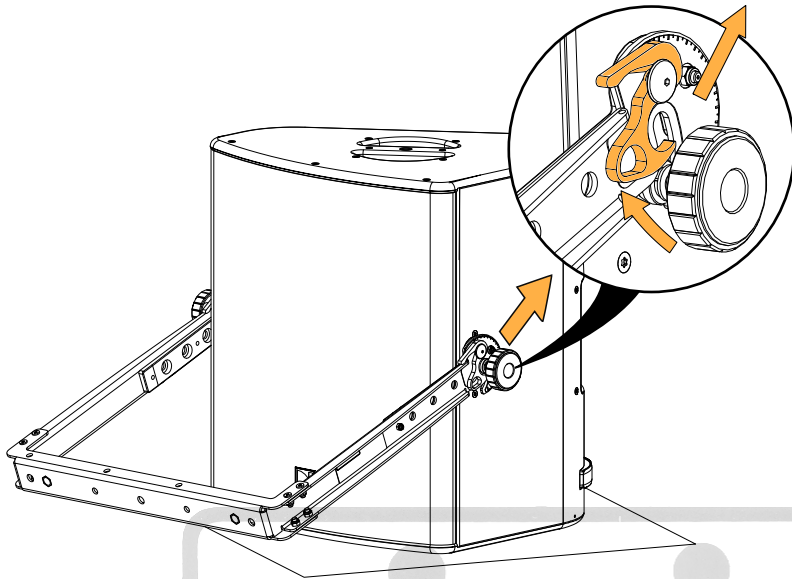

HI-FI
POWER

Flying with X-BAR

type of deployment	flying
rigging accessories	X-BAR
	Ø12 mm shackles WLL 1 t (provided)
	CLAMP250 (optional)
min number of operators	1

! Additional safety for flown arrays
When flying an enclosure, use the M8 DIN580 threaded insert to implement a secondary safety.

! Risk of damaging the insert and the cabinet
When flying X12 horizontally with X-BAR, always use the insert on the largest side (logo on the right). On the opposite side, the contact area between X-BAR and the cabinet is too small, which can cause the insert to be damaged through lever effect.

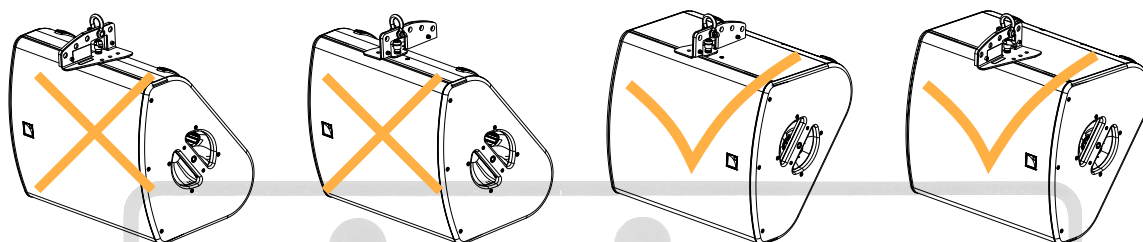

Site angles with X-BAR

X-BAR hole N°	site angle			
	horizontal		vertical	
	rear extension	front extension	rear extension	front extension
1	24°	4°	10.5°	-6°
2	14.5°	14°	3°	2°
3	5°	23°	-5°	10°
4	-4.5°	31.5°	-13°	17°
5	-14.5°	40°	-20.5°	25°

Assembly

Procedure

1. Lay the enclosure on a flat surface.

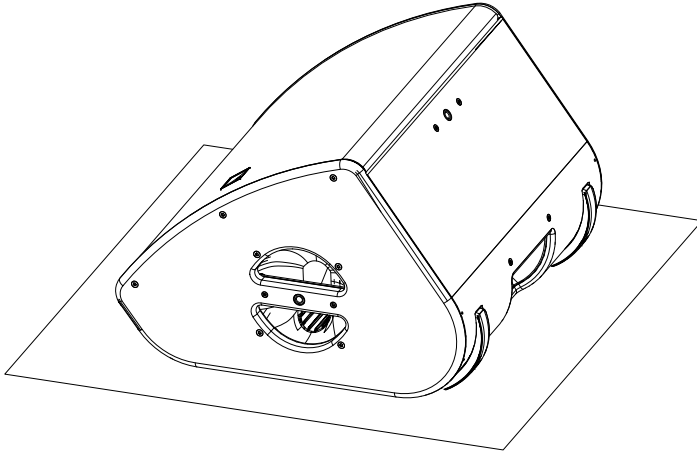

2. Drive the X-BAR in the insert.

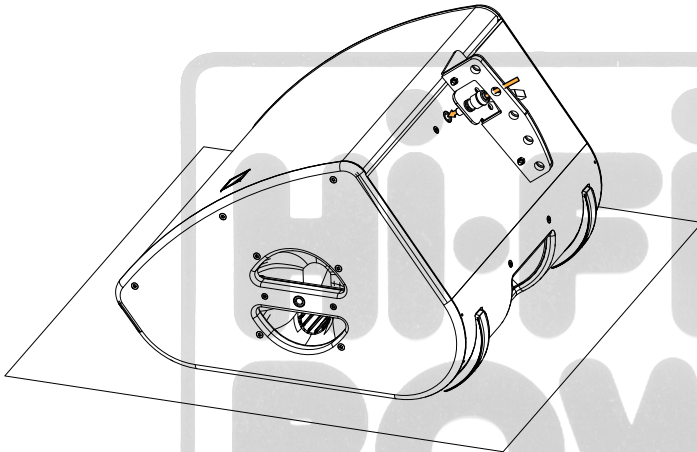

3. Rotate the X-BAR until perpendicular to the front grill.
Use the screws as reference points.

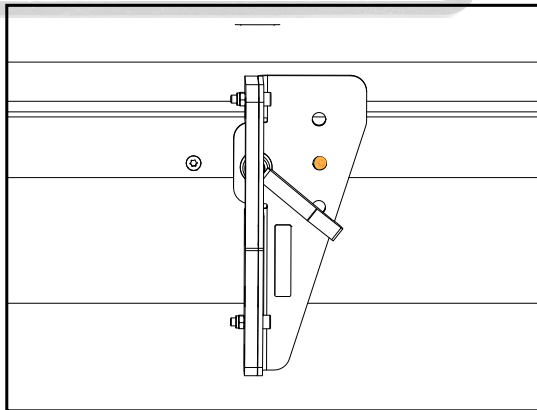
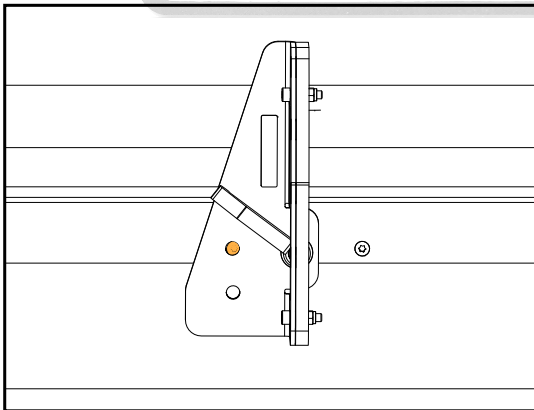

4. Tighten the X-BAR.

a) Lift the lever and rotate it counter-clockwise, release the lever and rotate it clockwise.

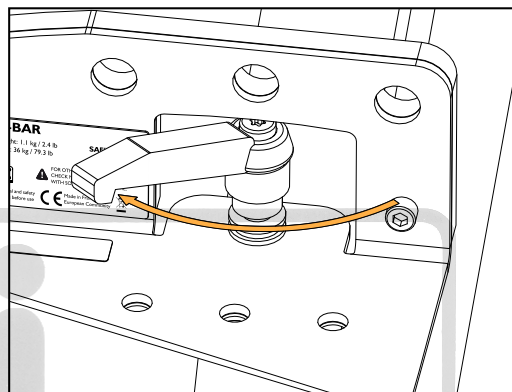
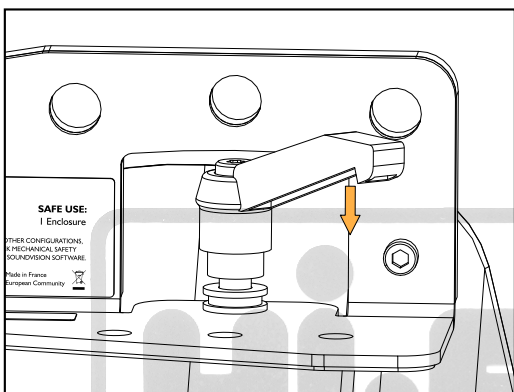
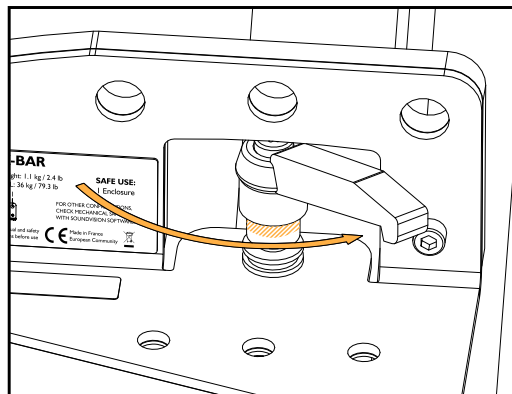
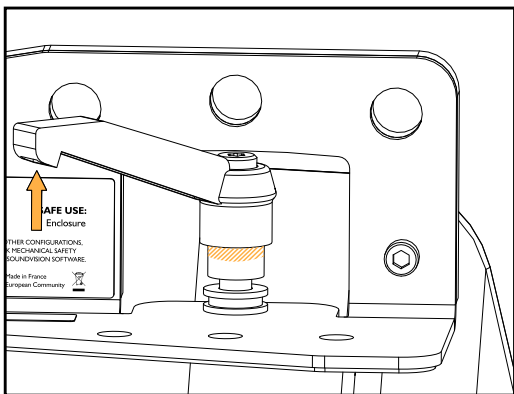

Repeat until the X-BAR is tightly secured.

b) Finally, store the lever on the right.

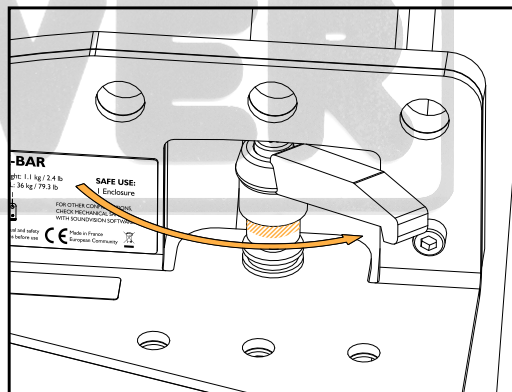
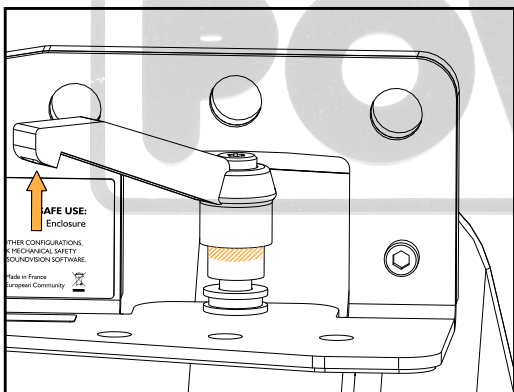

5. Position the shackle or CLAMP250 to select the site angle.

Refer to [Site angles with X-BAR](#) (p.63).

6. Lift the assembly.

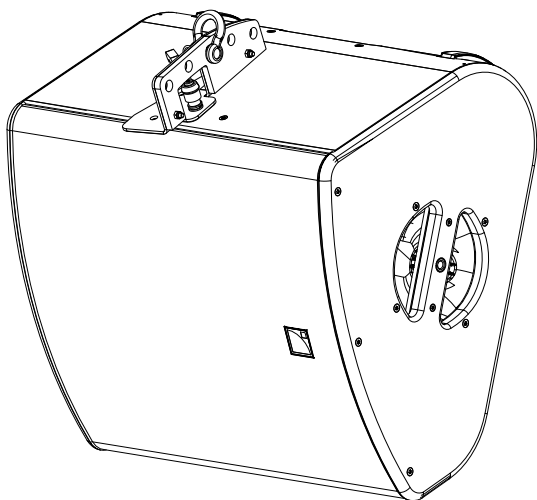

Disassembly

Procedure

1. Take down the assembly.
2. Lift the lever and rotate it clockwise.

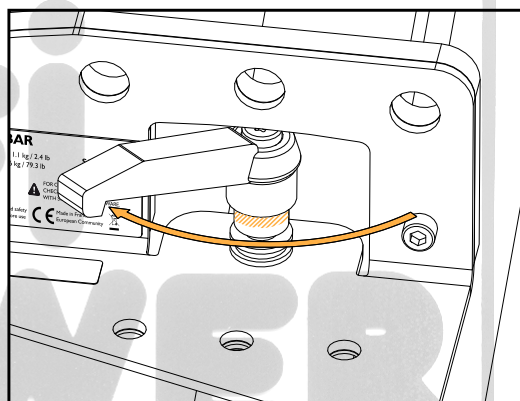
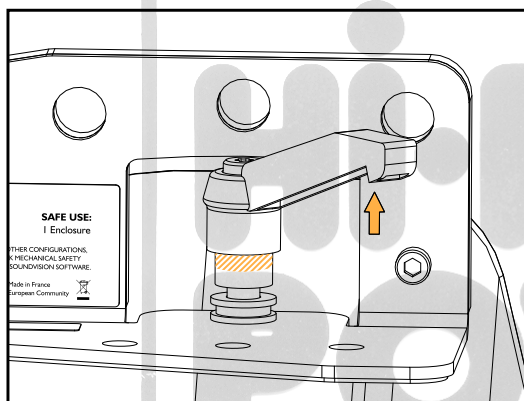

3. Release the lever and rotate it counter-clockwise.

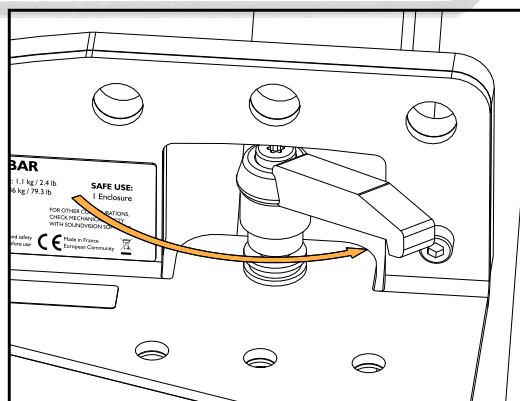
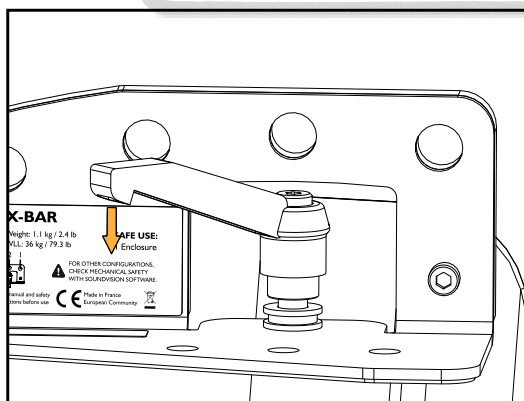

4. Repeat until the X-BAR can be removed.

Pole-mounting

Pole-mounting with X-US1215

type of deployment	pole-mounting
rigging accessories	X-US1215
	EMBi
additional material	35 mm pole
tools	torque screwdriver
	T30 Torx bit
	T40 Torx bit
	10 mm wrench
	13 mm wrench
min number of operators	1

Risk of damaging the bracket safety mechanism

When using X-US1215 and EMBi for pole-mounting X12, always use the additional holes on the bracket.
Do not use X-UL12 with EMBi.

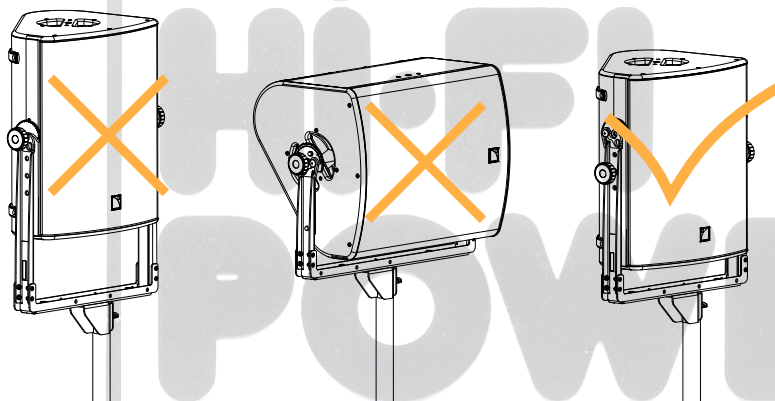

Assembly

Procedure

1. Secure EMBi to the U-bracket with the provided bolts and nuts.

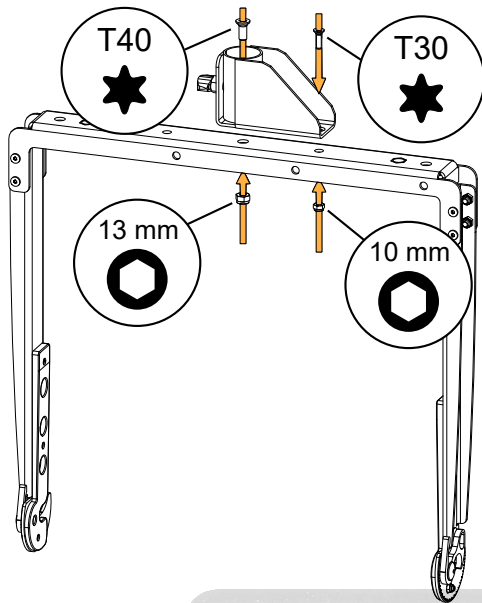

2. Secure the U-bracket to the enclosure using the additional holes.



The hooks on the bracket must be oriented towards the front of the enclosure.

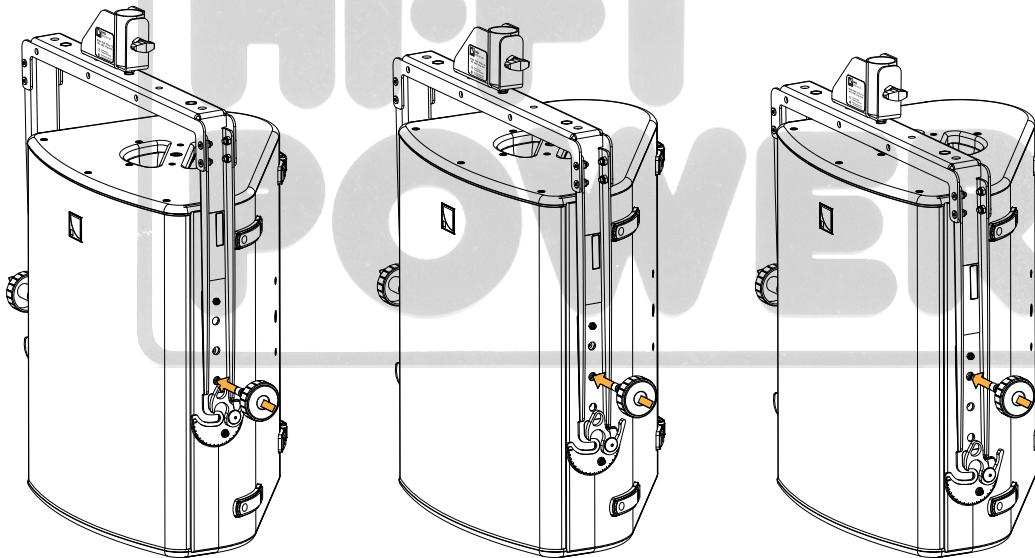

Make sure the safety washer goes through the hole on the bracket.

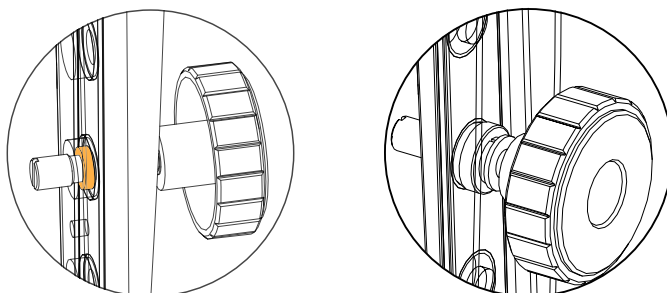

3. Tighten the knobs, reverse the assembly and mount it on a pole.

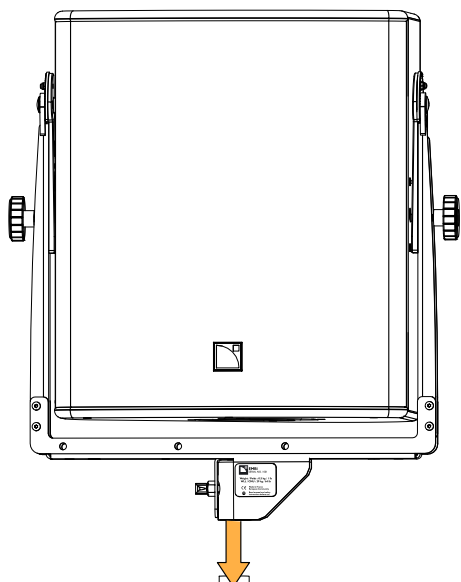

4. Tighten EMBi.

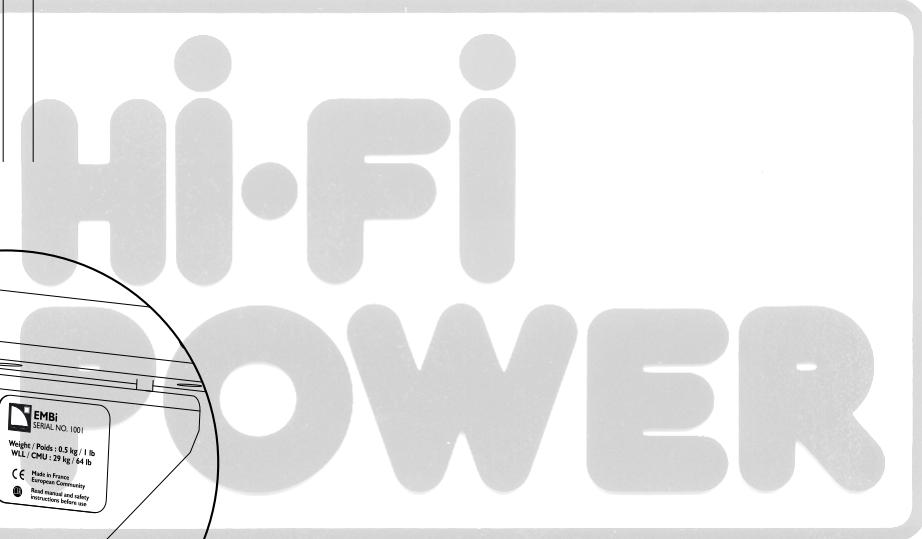
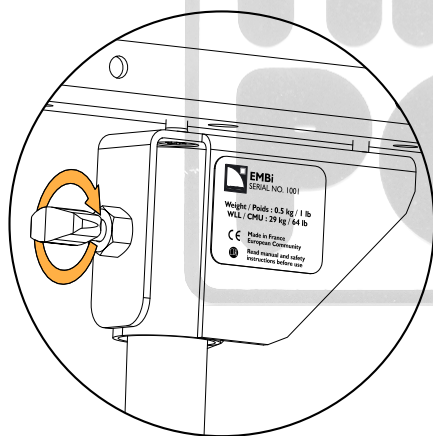

5. Loosen the knobs to set the site angle.



Consider the maximum positive site angle available.

Maximum angles

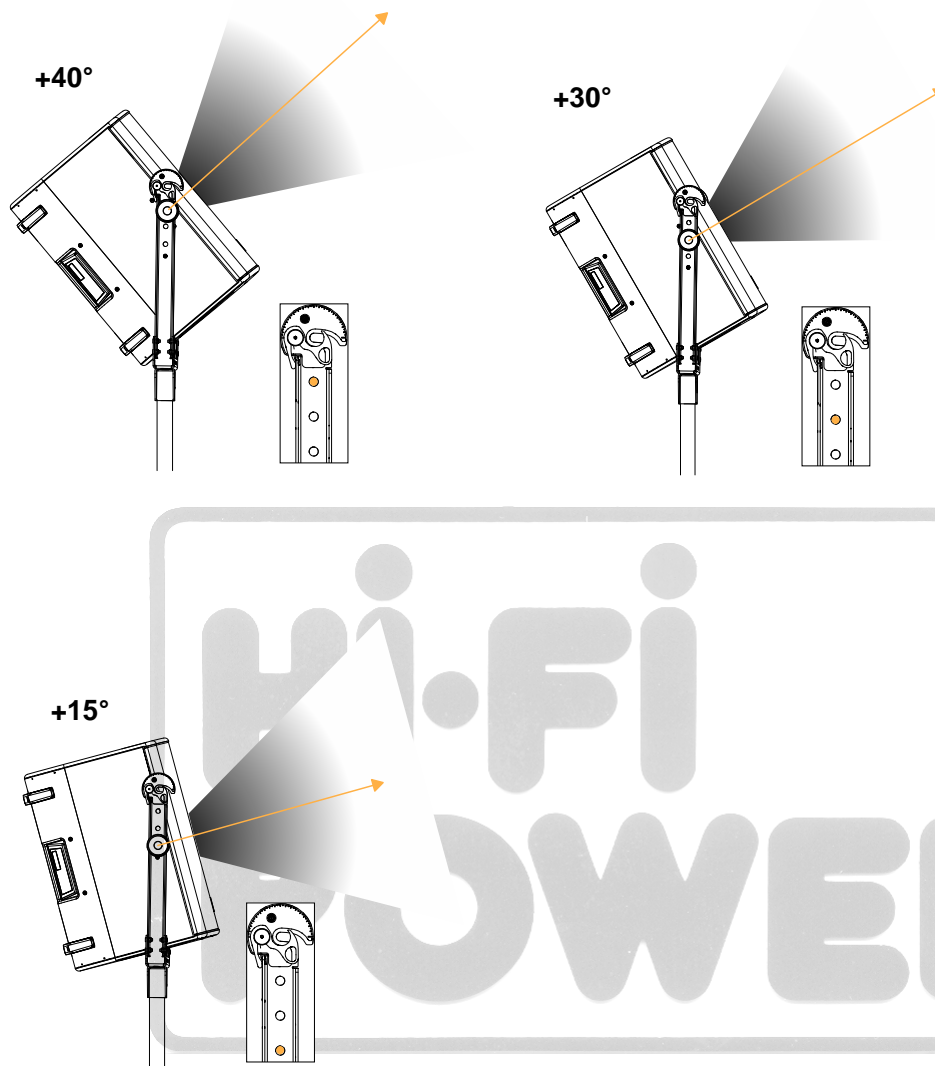

6. Tighten the knobs.

Make sure the enclosure is steady.

The assembly can be mounted on a tripod or on a subwoofer.

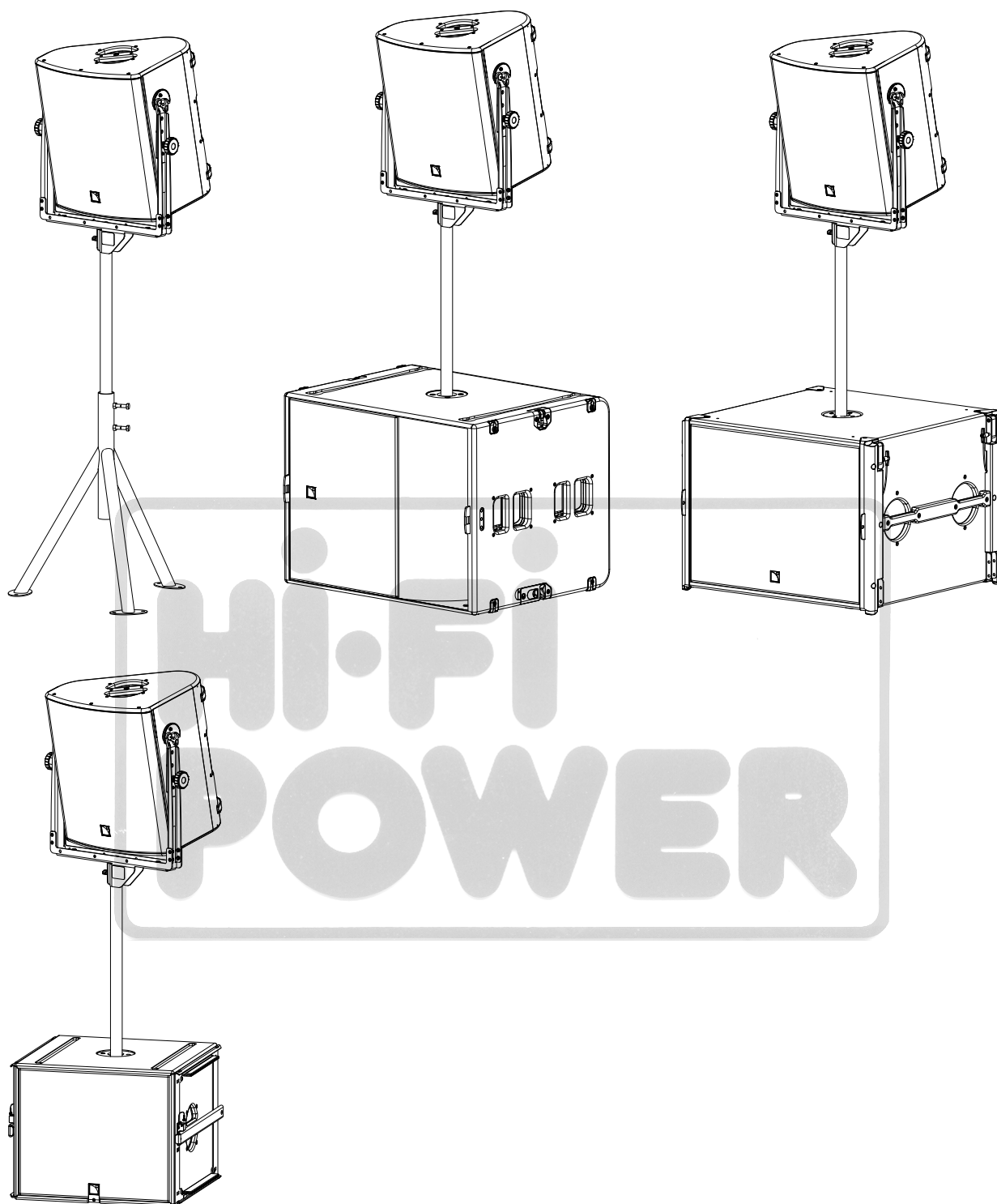

Disassembly

About this task



Remove the assembly from the pole before disassembling the enclosure and the bracket.

Procedure

1. Loosen EMBi to remove the assembly from the pole.

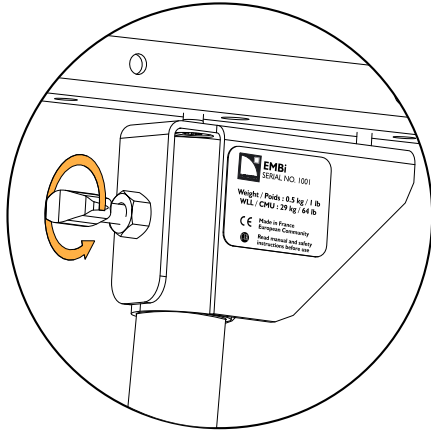

2. Remove the bracket from the enclosure.

Hi-Fi
POWER

Connection to LA amplified controllers

! Refer to the **Amplification reference** technical bulletin for the latest information on compatibility with amplified controllers and cabling schemes for all enclosure types.

Enclosure drive capacity per amplified controller

Make sure the total number of connected enclosures does not exceed the maximum number of enclosures per controller (refer to the footnotes).

	LA4X	LA8	LA12X
	per output* / total	per output* / total	per output* / total
X12	1 / 4	2 / 8	3 / 12

Cabling schemes for X12

Refer to the cabling schemes to connect the enclosures to different types of output configurations.

One-channel speakON output

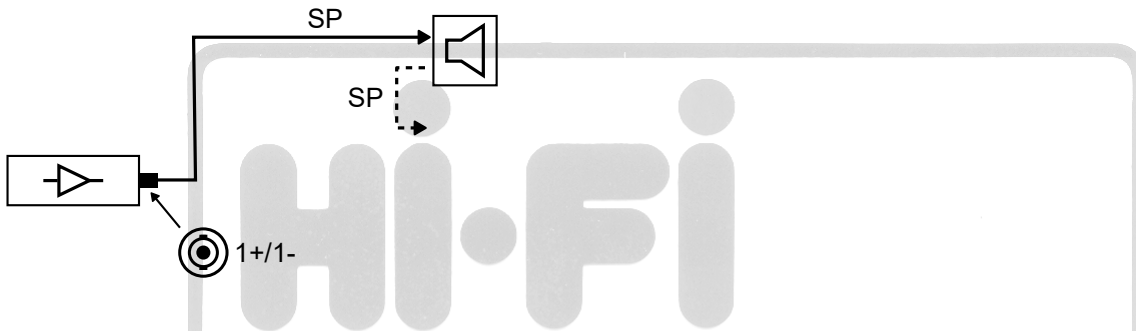

Two-channel speakON output

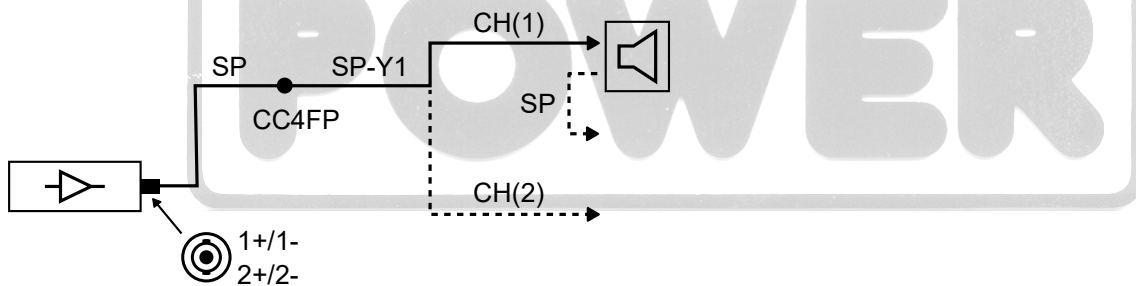

Four-channel CA-COM output

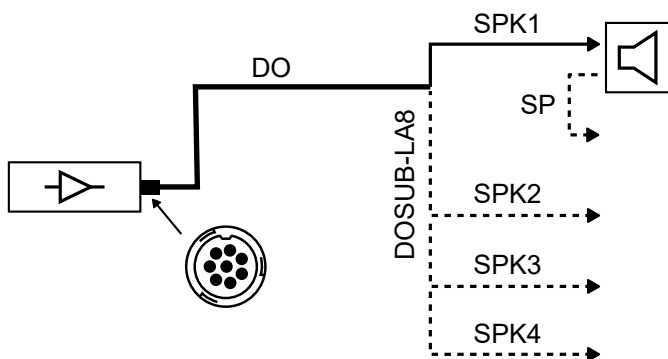

* For passive loudspeakers, the value corresponds to the number of enclosures in parallel on the output. For active loudspeakers, the value corresponds to the number of sections in parallel on the output.

Corrective maintenance

Introduction

This section contains the following maintenance procedures:

- [Grill](#) (p.76)
- [Coaxial loudspeaker](#) (p.77)
- [HF diaphragm](#) (p.78)

For advanced maintenance, contact your L-Acoustics representative.

Tools and consumables

Before performing maintenance on this product, make sure all the tools listed are available. References are given for FACOM® products in this table. Other manufacturers can be used.

name	reference	distributor
Set of 6-point 1/4" sockets *	RL.NANO1 / R.360NANO	FACOM
Torque screwdriver (2 - 10 N.m) *	A.404	FACOM
3 mm hex wrench	-	-
compressed air blower	-	-
double face adhesive tape	-	-

i * included in the L-Acoustics Maintenance Toolcase.

Maintenance Toolcase

The Maintenance Toolcase is a carry-on suitcase that includes all the tools required to perform maintenance on L-Acoustics products. This toolcase is aimed at Certified Providers.

The Maintenance Toolcase uses a Peli™ 1510 Protector case that features three pre-cut layers of foam to safely fit the tools. The Maintenance Toolcase includes tools manufactured by FACOM®, Fluke®, Tohnichi, ABUS, and Würth.

i All third-party trademarks, registered trademarks, or product names are the property of their respective owners.

X12

Disassembly and Reassembly procedures

In order to operate, follow the order outlined here. Each assembly refers to the corresponding D/R procedure and the necessary repair kit.

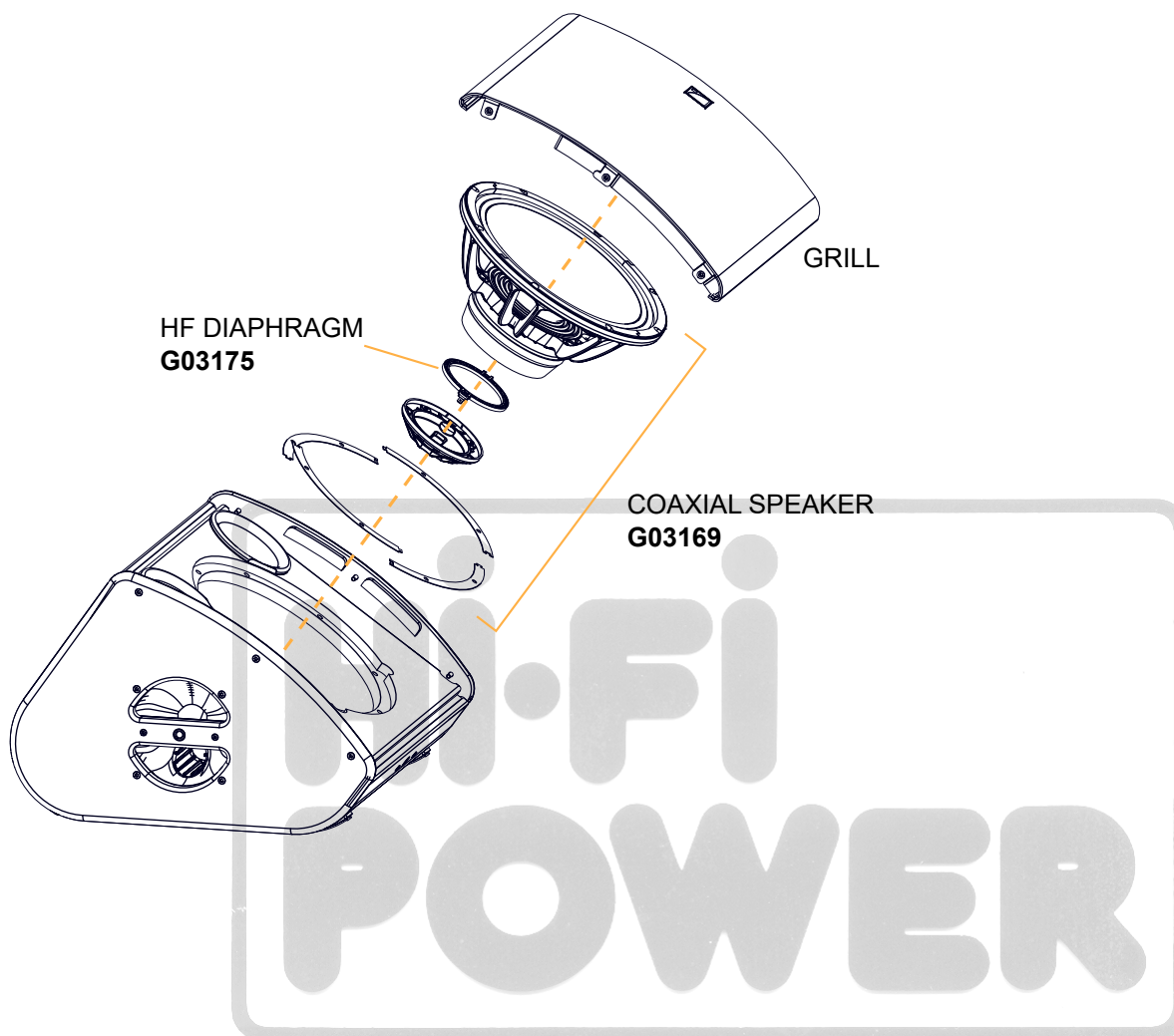

D/R - Grill

Tools

- torque screwdriver
- T25 Torx bit

Repair kit

G03169 - KR coaxial speaker X12 or

G03175 - KR diaphragm X12

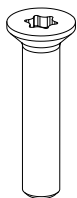

x6

S100033

M5x25 Torx

Exploded view

! For safety reasons, always use the new screws and spare parts provided in the KR.
If no new screws are available, use blue threadlocker.

! Gradually tighten the screws following a star pattern.

Position the logo on the right side.

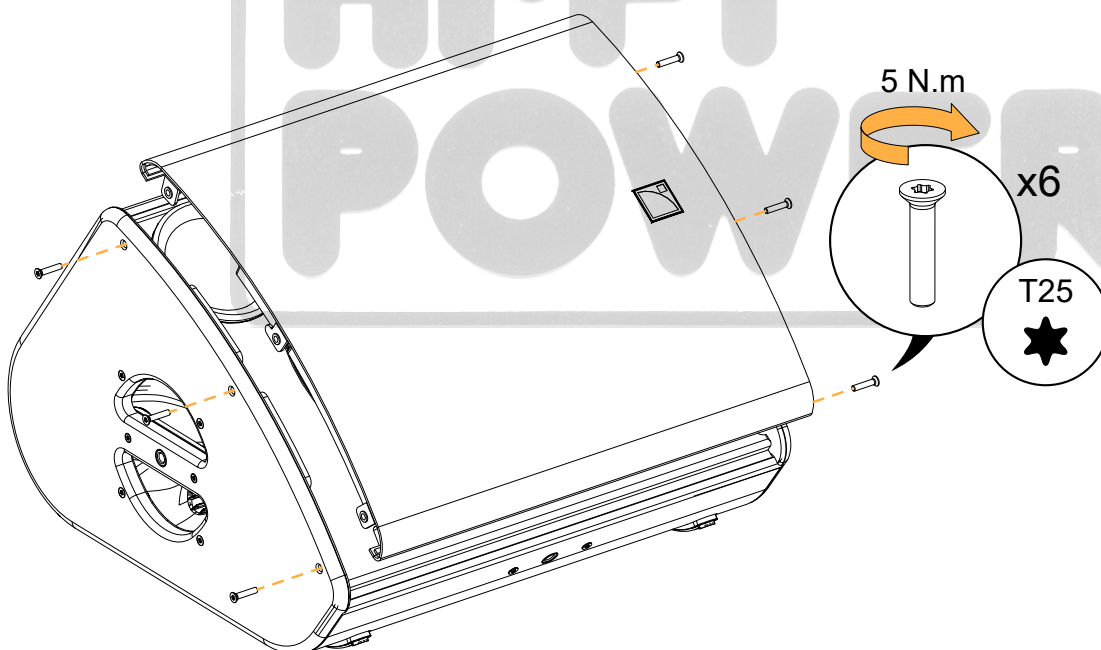

D/R - Coaxial loudspeaker

Tools

- torque screwdriver
- 5 mm hex bit

Repair kit

G03169

KR coaxial speaker X12

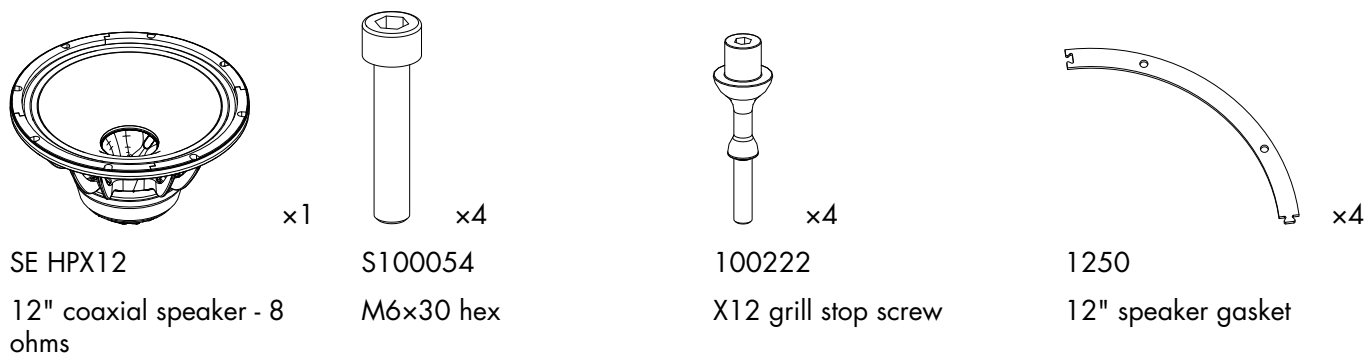



Prerequisite

Grill disassembled.

See [Grill](#) (p.76).

Exploded view

-  For safety reasons, always use the new screws and spare parts provided in the KR.
-  Gradually tighten the screws following a star pattern.
-  If the speaker gasket is damaged, remove and replace it.

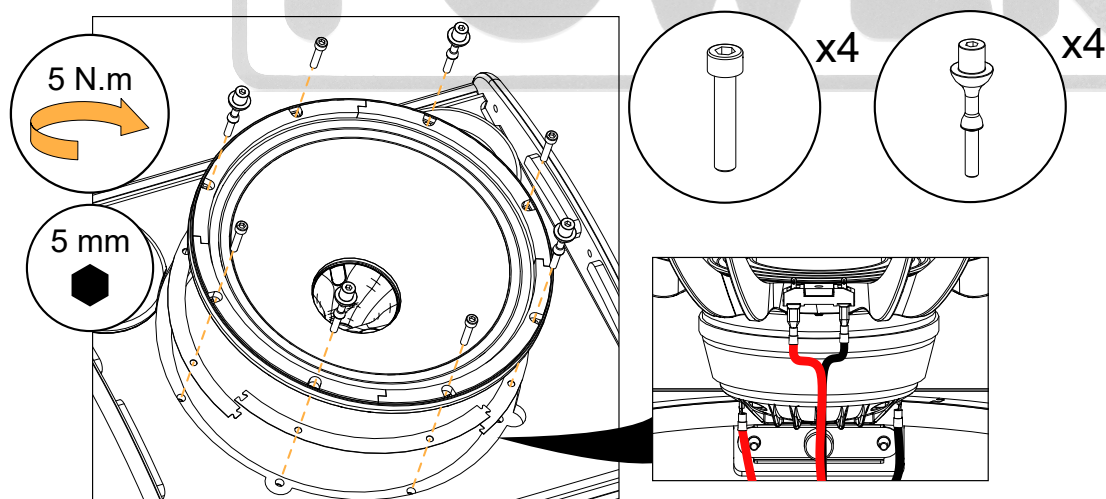

What to do next

Perform the [Acoustical check](#) (p.42) procedures.

D/R - HF diaphragm

Tools

- torque screwdriver
- 3 mm hex wrench
- 3 mm hex bit
- blower

Consumables

- double face adhesive tape

Repair kit

G03175

KR diaphragm X12

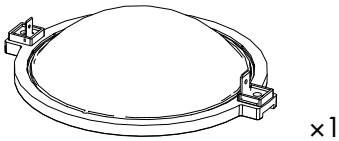

x1

17581

diaphragm assembly (with 2 shims)



x4

S100082

M4x14 hex

Prerequisite

Grill disassembled.

See [Grill](#) (p.76).

Coaxial speaker removed.

See [Coaxial loudspeaker](#) (p.77).

The speaker is placed on a flat surface in a dust-free environment.

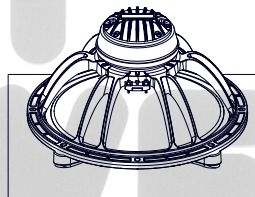

Disassembly

Procedure

1. Remove the four screws securing the cover.
Use the 3 mm hex bit.
2. Remove the cover.
3. Carefully remove the diaphragm.
4. If there are shims on the dome, carefully remove them.
Take note of how many and what kind of shims are present.

Reassembly

About this task

! For safety reasons, always use the new screws and spare parts provided in the KR.

Procedure

1. Clean the dome and the air gap.

Use a blower or double face adhesive tape to remove any particle.

! Make sure the air gap is perfectly clean before moving to the next step.

2. Place the same kind and number of shims that were initially present.
3. Carefully place the diaphragm.
4. Position the diaphragm using the LF cable connectors as reference points.
Place the small HF connector on the same side as the small LF connector.
5. Secure the cover to the speaker using four S100082 screws.
 - a) Gradually secure each screw manually with the 3 mm hex wrench.

Follow a cross scheme.

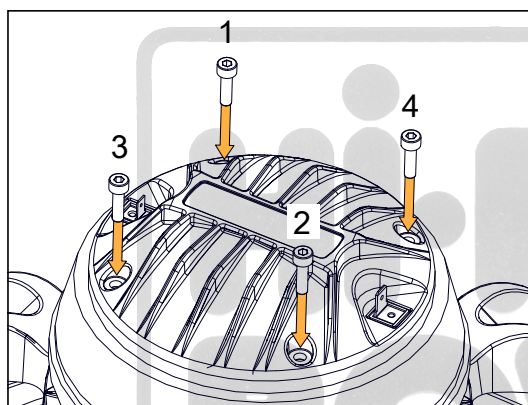

- b) Tighten the screws in the same order with the electric screwdriver.
Use the 3 mm hex bit. Set the torque to 3.5 Nm.

What to do next

Perform the [Acoustical check](#) (p.42) procedures.

Specifications

X12 specifications

Description	2-way passive coaxial enclosure: 12" LF + 3" HF diaphragm, amplified by LA4X / LA8 / LA12X
Usable bandwidth (-10 dB)	59 Hz - 20 kHz ([X12])
Maximum SPL¹	136 dB ([X12])
Nominal directivity (-6 dB)	vertical: 90° horizontal: 60°
Monitoring angle	without risers: 35° with risers: 55°
Transducers	LF: 1 × 12" cone driver HF: 1 × 3" diaphragm compression driver, neodymium
Acoustical load	bass-reflex, L-Vents, ellipsoidal waveguide
Nominal impedance	8 Ω
Connectors	IN: 1 × 4-point speakON LINK: 1 × 4-point speakON
Rigging and handling	2 × handles DIN580-compatible M8 threaded insert 4 M10 threaded inserts 2 × 35 mm pole socket
Weight (net)	20 kg / 44.1 lb
Cabinet	premium grade Baltic beech and birch plywood
Front	steel with anti-corrosion coating acoustically neutral 3D fabric
Finish	dark grey brown Pantone 426 C pure white RAL 9010 custom RAL code on special order
IP	IP43

¹ Peak level measured at 1 m under free field conditions using pink noise with crest factor 4 (preset specified in brackets).

X12 dimensions

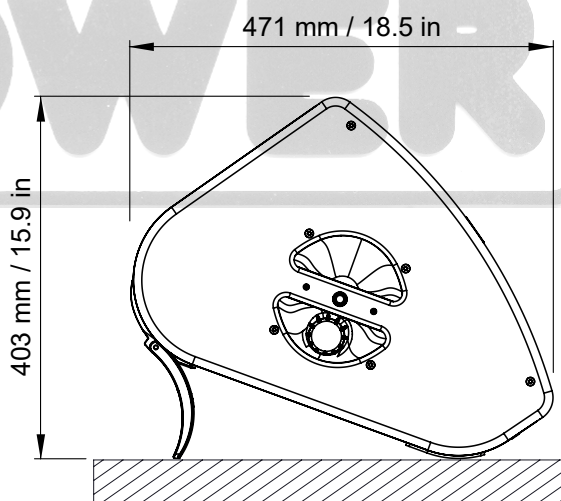
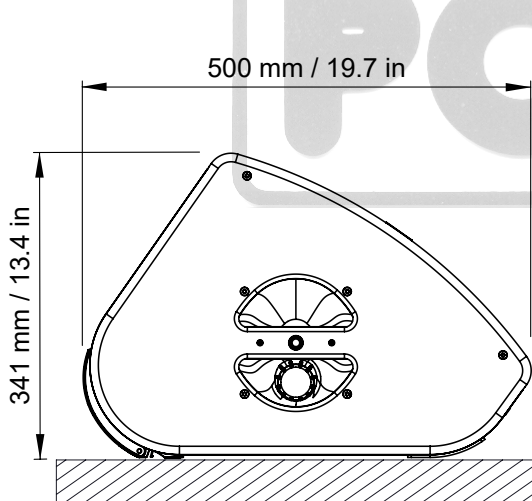
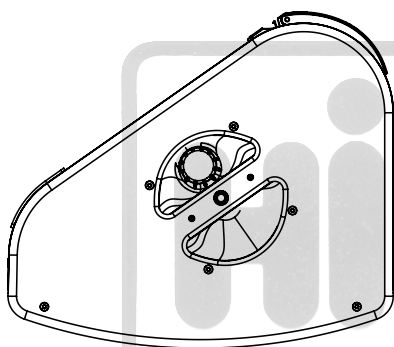
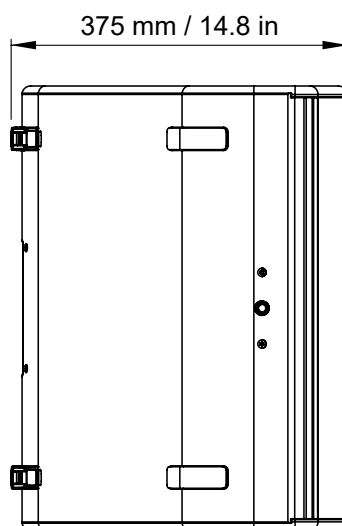
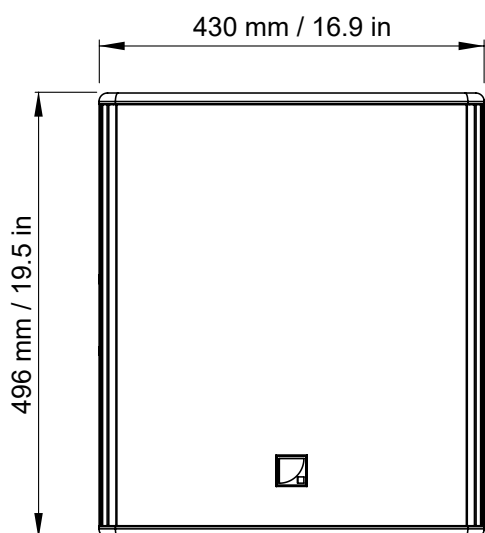

SB15m specifications

Description	High power compact subwoofer : 1 x 15" , amplified by LA2Xi / LA4X / LA8 / LA12X
Low frequency limit	40 Hz ([SB15_100])
Maximum SPL¹	137 dB ([SB15_100]) with LA2Xi (bridge mode) / LA4X / LA8 / LA12X 131 dB ([SB15_100]) with LA2Xi
Directivity	standard or cardioid
Transducers	1 x 15" cone driver
Acoustical load	bass-reflex, L-Vents
Nominal impedance	8 Ω
Connectors	IN: 1 x 4-point speakON LINK: 1 x 4-point speakON
Rigging and handling	2 handles 2 coupling bars and 2 locking tabs 1 x 35 mm pole socket
Weight (net)	36 kg / 79.4 lb
Cabinet	premium grade Baltic birch plywood
Front	coated steel grill acoustically neutral 3D fabric
Rigging components	high grade steel with anti-corrosion coating
Finish	dark grey brown Pantone 426 C pure white RAL 9010 custom RAL code on special order
IP	IP55

¹ Peak level at 1 m under half space conditions using pink noise with crest factor 4 (preset specified in brackets).

SB15m dimensions

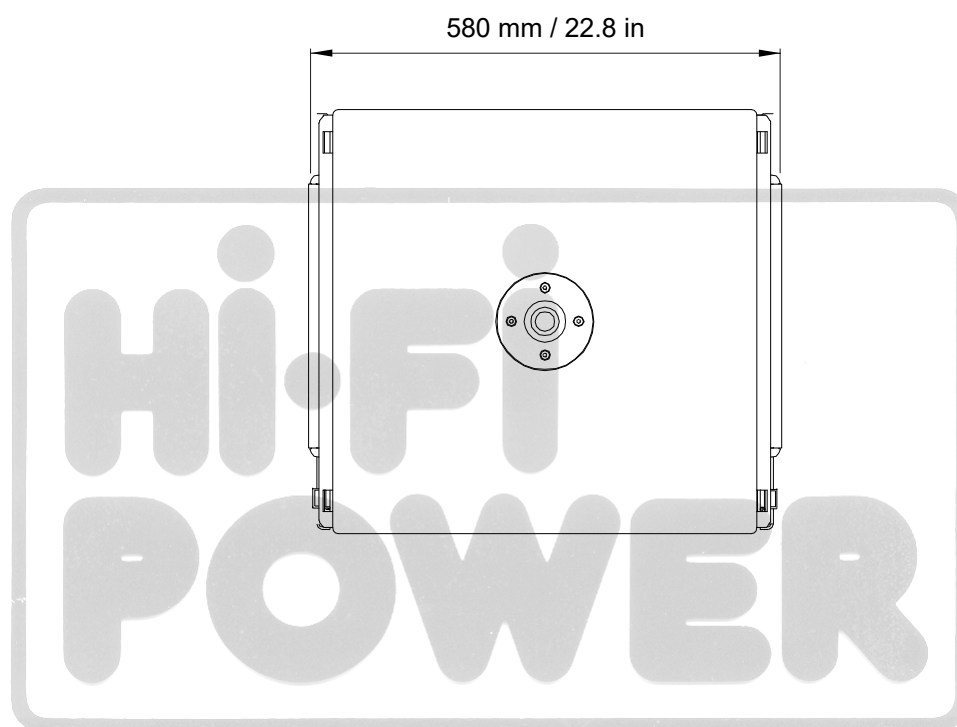
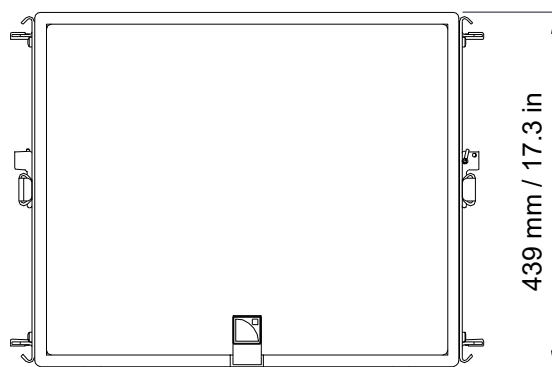
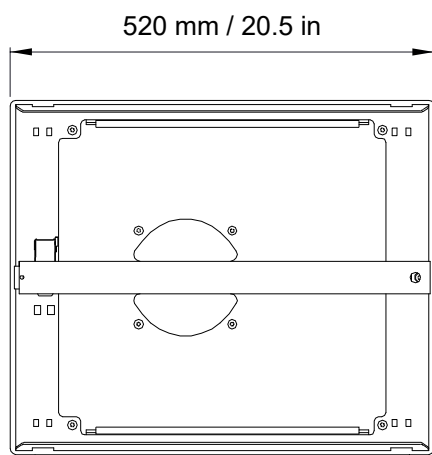

SB18 specifications

Description	High power compact subwoofer: 1 x 18" , amplified by LA4X / LA8 / LA12X
Low frequency limit (-10 dB)	32 Hz ([SB18_100])
Maximum SPL¹	138 dB ([SB18_100])
Nominal directivity (-6 dB)	standard or cardioid
Transducers	1 x 18"
Acoustical load	dual bass-reflex, L-Vents
Nominal impedance	8 Ω
Connectors	IN: 1 x 4-point speakON LINK: 1 x 4-point speakON
Rigging and handling	4 handles integrated into the cabinet captive rigging system 1 x 35 mm pole socket
Weight (net)	52 kg / 115 lb
Cabinet	premium grade Baltic birch plywood
Front	coated steel grill acoustically neutral 3D fabric
Rigging components	steel with anti-corrosion coating
Finish	dark grey brown Pantone 426 C
IP	IP55

¹ Peak level at 1 m under half space conditions using pink noise with crest factor 4 (preset specified in brackets).

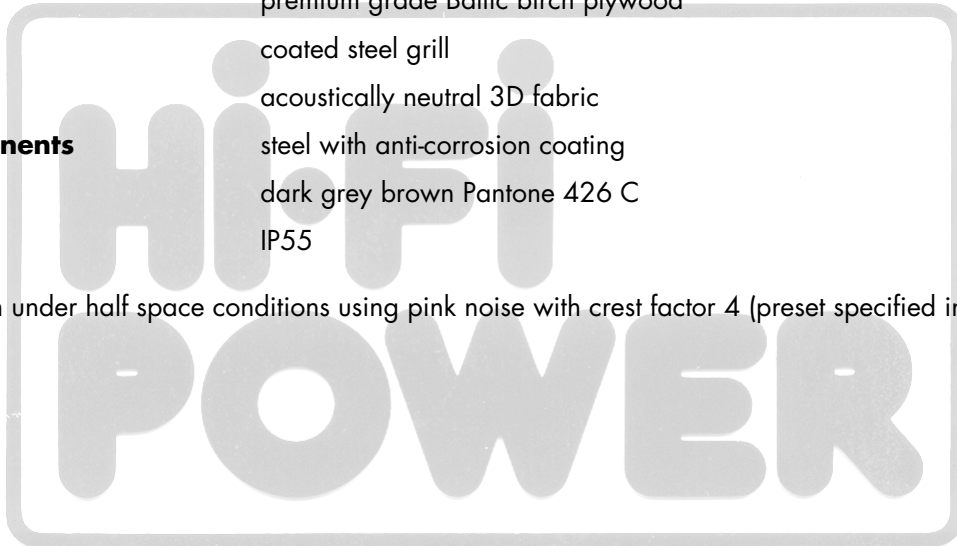

SB18 dimensions

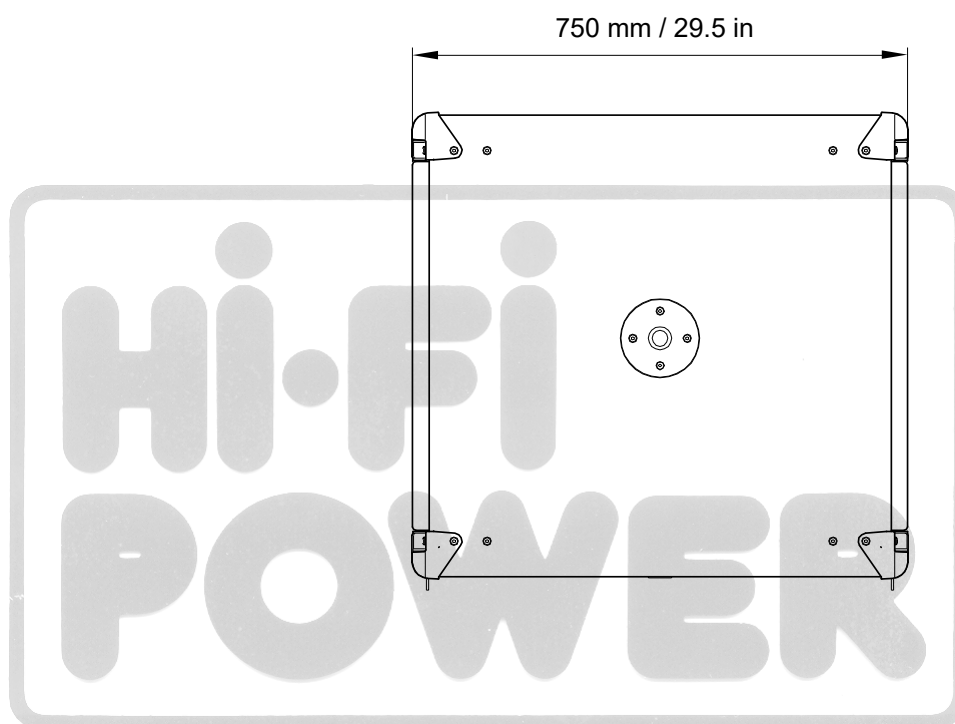
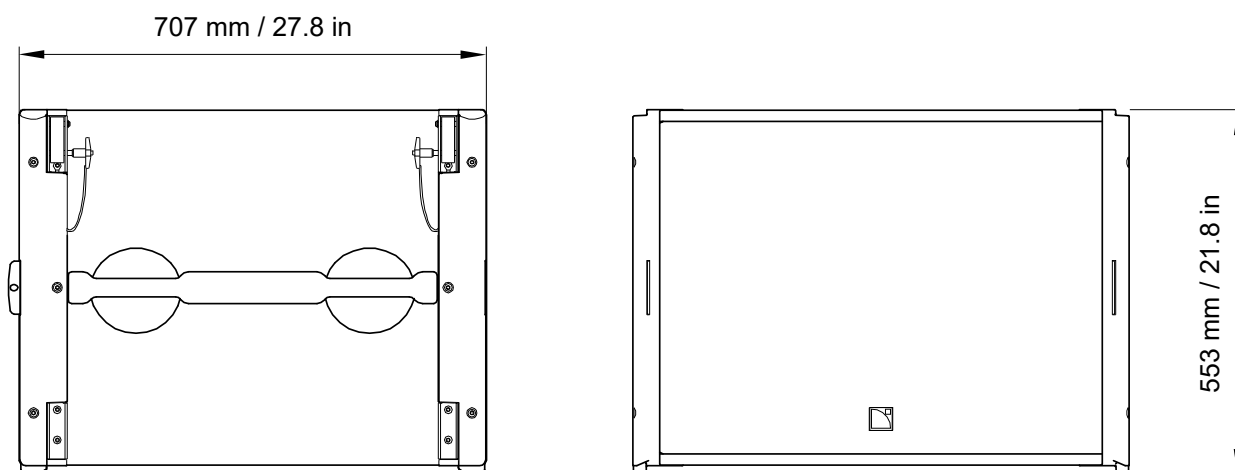

SB18 Ili specifications

Description	High power compact subwoofer: 1 x 18" (installation version), amplified by LA2Xi / LA4X / LA8 / LA12X
Low frequency limit (-10 dB)	32 Hz ([SB18_100])
Maximum SPL¹	138 dB ([SB18_100]) with LA2Xi (bridge mode) / LA4X / LA8 / LA12X 133 dB ([SB18_100]) with LA2Xi
Directivity	standard or cardioid
Transducers	1 x 18" cone driver
Acoustical load	dual bass-reflex
Nominal impedance	8 Ω
Connectors	1 x 4-point terminal block with push-in connection
Rigging and handling	external rigging kits 12 M6 inserts for rigging 8 M6 inserts for screens
Weight (net)	48 kg / 106 lb
Cabinet	premium grade Baltic birch plywood
Front	coated steel grill
Finish	acoustically neutral 3D fabric dark grey brown Pantone 426 C pure white RAL 9010 custom RAL code on special order
IP	IP55

¹ Peak level at 1 m under half space conditions using pink noise with crest factor 4 (preset specified in brackets).

SB18 Ili dimensions

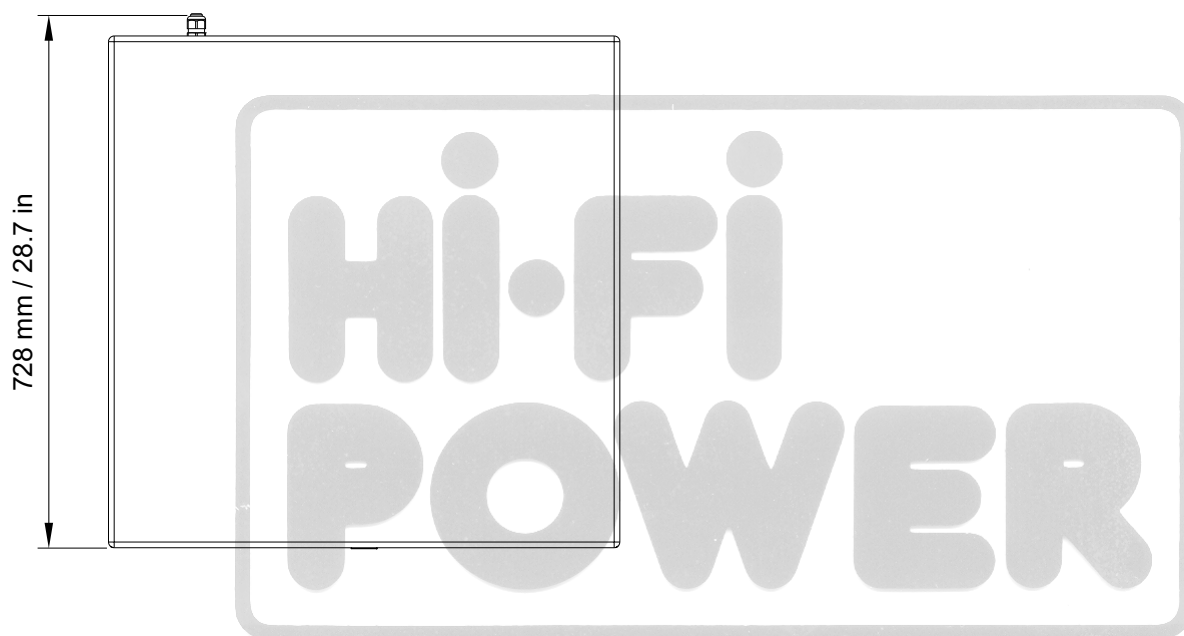
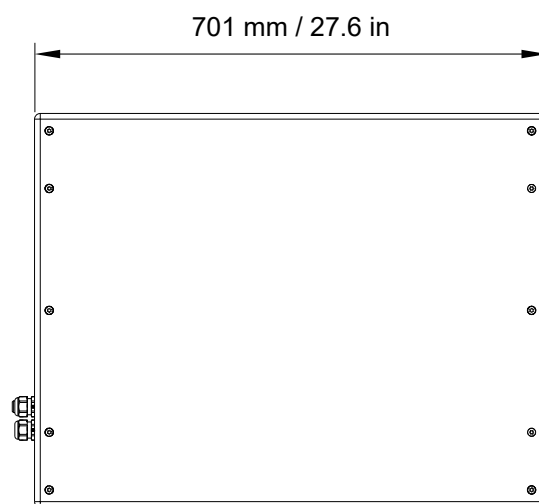
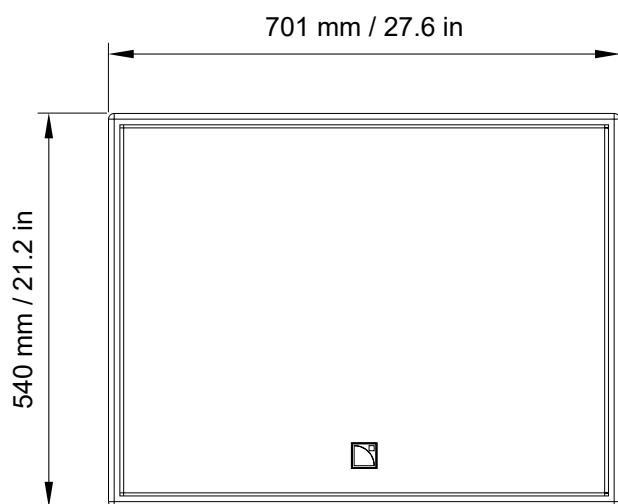

KS21 specifications

Description	High power compact subwoofer: 1x21" , amplified by LA4X / LA8 / LA12X
Low frequency limit (-10 dB)	31 Hz ([KS21_100])
Maximum SPL¹	138 dB ([KS21_100])
Nominal directivity (-6 dB)	standard or cardioid configuration
Transducers	1 × 21" neodymium cone driver
Acoustical load	bass-reflex, L-Vents
Nominal impedance	8 Ω
Connectors	IN: 1 × 4-point speakON LINK: 1 × 4-point speakON
Rigging and handling	flush-fitting 2-point rigging system 4 handles 8 corner stops 2 ground runners 1 pole mount with M20×150 insert
Weight (net)	49 kg / 108 lb
Cabinet	premium grade Baltic beech and birch plywood
Front	coated steel grill acoustically neutral 3D fabric
Rigging components	high grade steel with anti-corrosion coating
Finish	dark grey brown Pantone 426 C
IP	IP55

¹ Peak level at 1 m under half space conditions using pink noise with crest factor 4 (preset specified in brackets).

KS21 dimensions

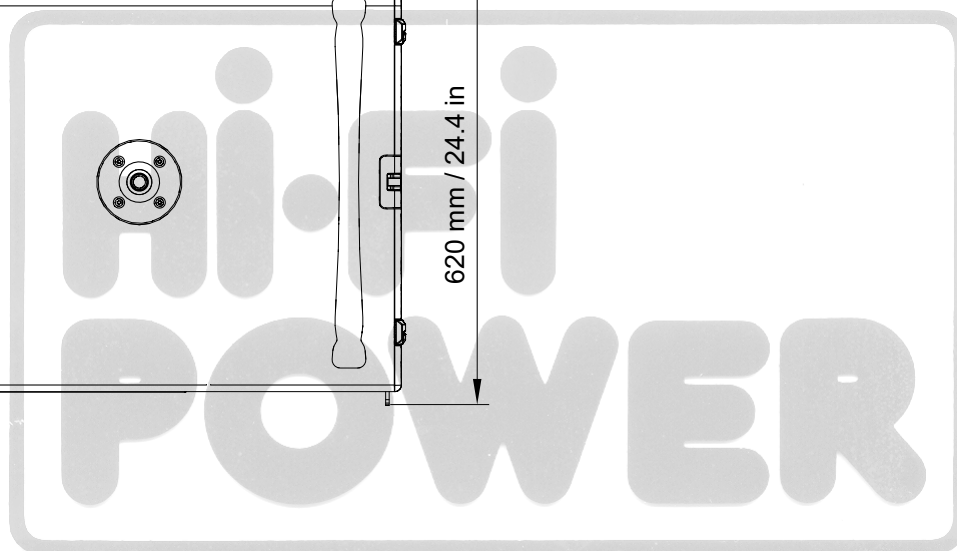
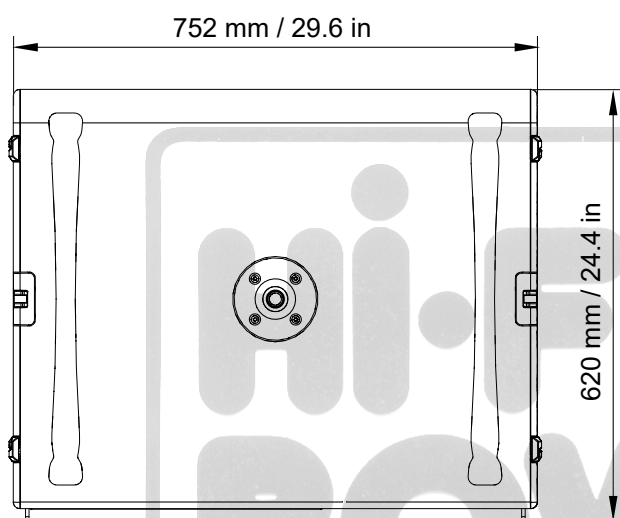
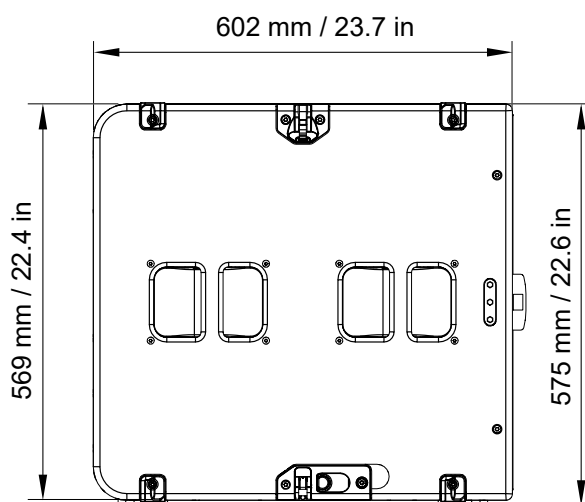
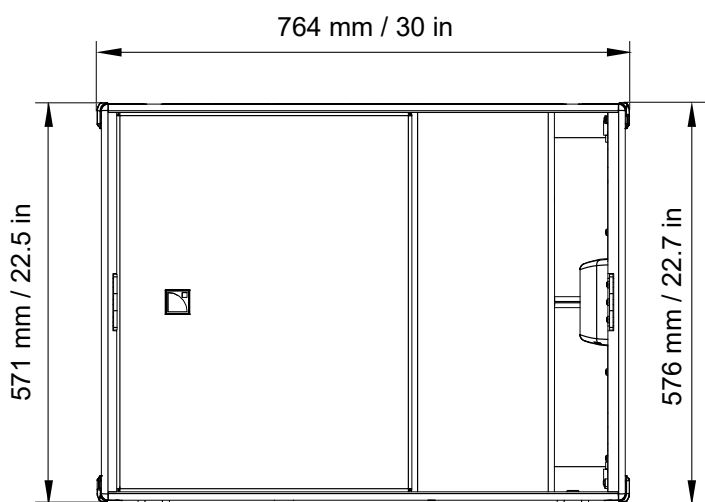

KS21i specifications

Description	High power compact subwoofer: 1 x 21" (installation version), amplified by LA2Xi / LA4X / LA8 / LA12X
Low frequency limit (-10 dB)	31 Hz ([KS21_100])
Maximum SPL ¹	138 dB ([KS21_100]) with LA2Xi (bridge mode) / LA4X / LA8 / LA12X 131 dB ([KS21_100]) with LA2Xi
Nominal directivity (-6 dB)	standard or cardioid configuration
Transducers	1 x 21" neodymium cone driver
Acoustical load	bass-reflex, L-Vents
Nominal impedance	8 Ω
Connectors	1 x 4-point terminal block with push-in connection
Rigging and handling	external rigging kits M6 inserts for rigging plates M8 inserts for A-U15i 1 DIN580-compatible M8 threaded insert
Weight (net)	46 kg / 101 lb
Cabinet	premium grade Baltic beech and birch plywood
Front	coated steel grill acoustically neutral 3D fabric
Finish	dark grey brown Pantone 426 C pure white RAL 9010 custom RAL code on special order
IP	IP55

¹ Peak level at 1 m under half space conditions using pink noise with crest factor 4 (preset specified in brackets).

KS21i dimensions

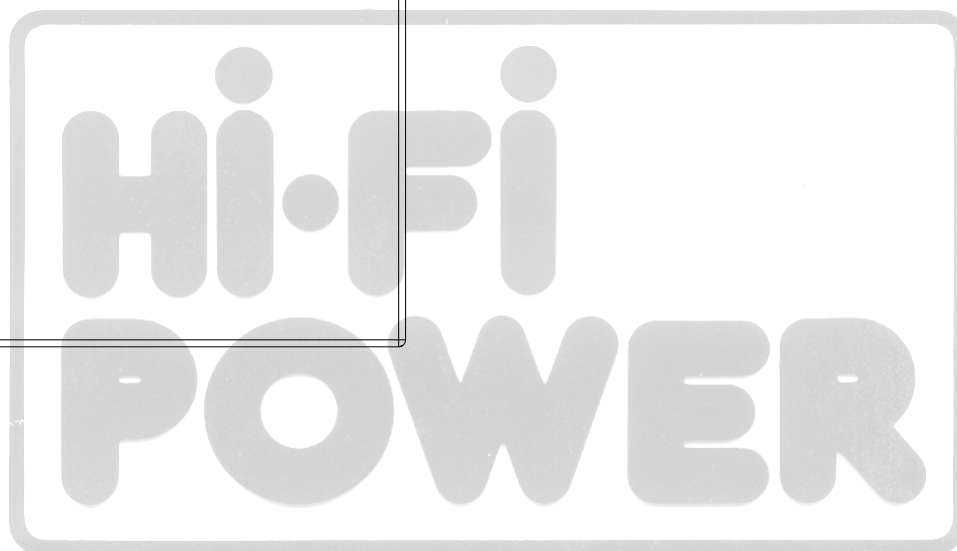
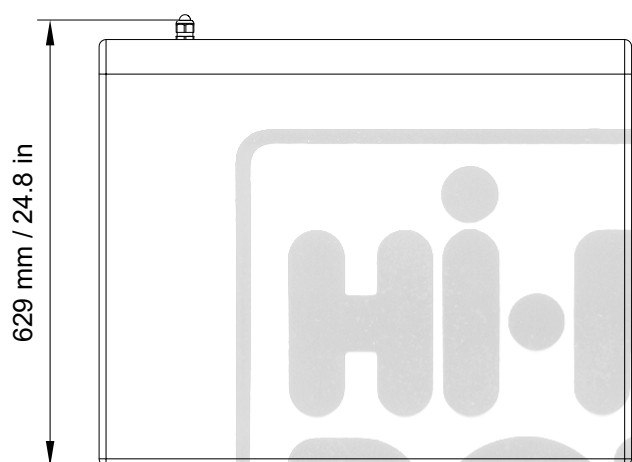
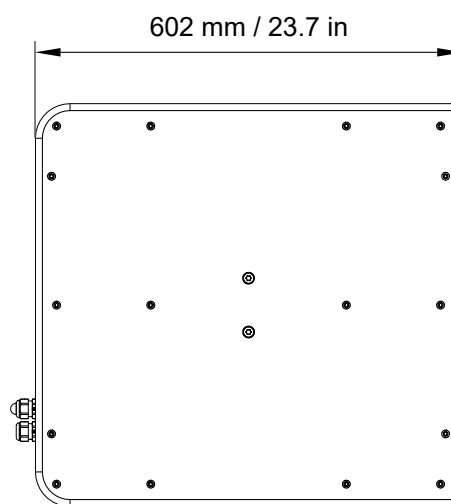
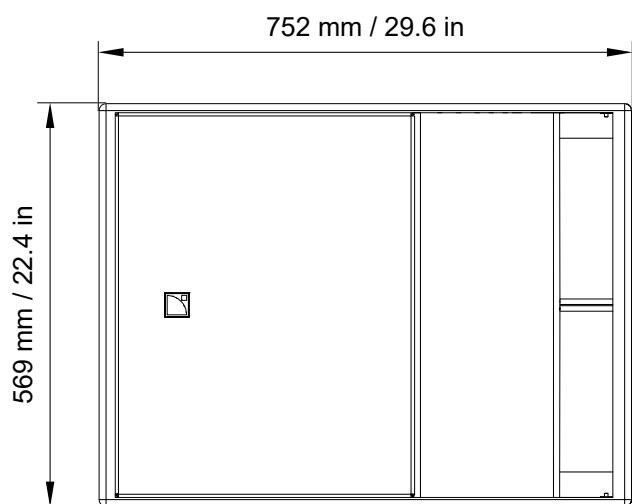

X-UL12 specifications

Description	Long U-bracket for X12
Weight (net)	2.7 kg / 5.9 lb
Material	high grade steel with anti-corrosion coating

X-UL12 dimensions

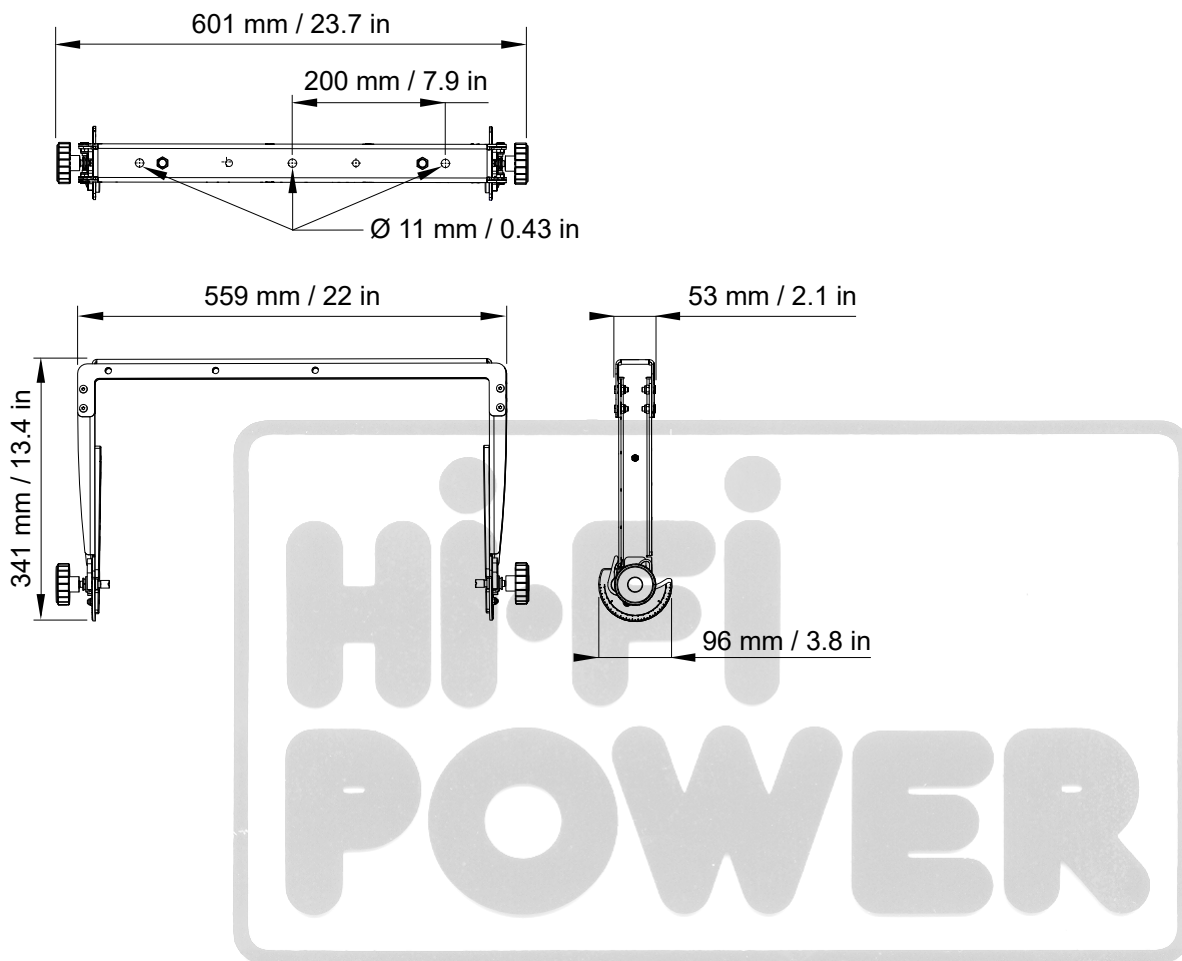

X-US1215 specifications

Description	Short U-bracket for X12 and X15 HiQ
Weight (net)	3 kg / 6.6 lb
Material	high grade steel with anti-corrosion coating

X-US1215 dimensions

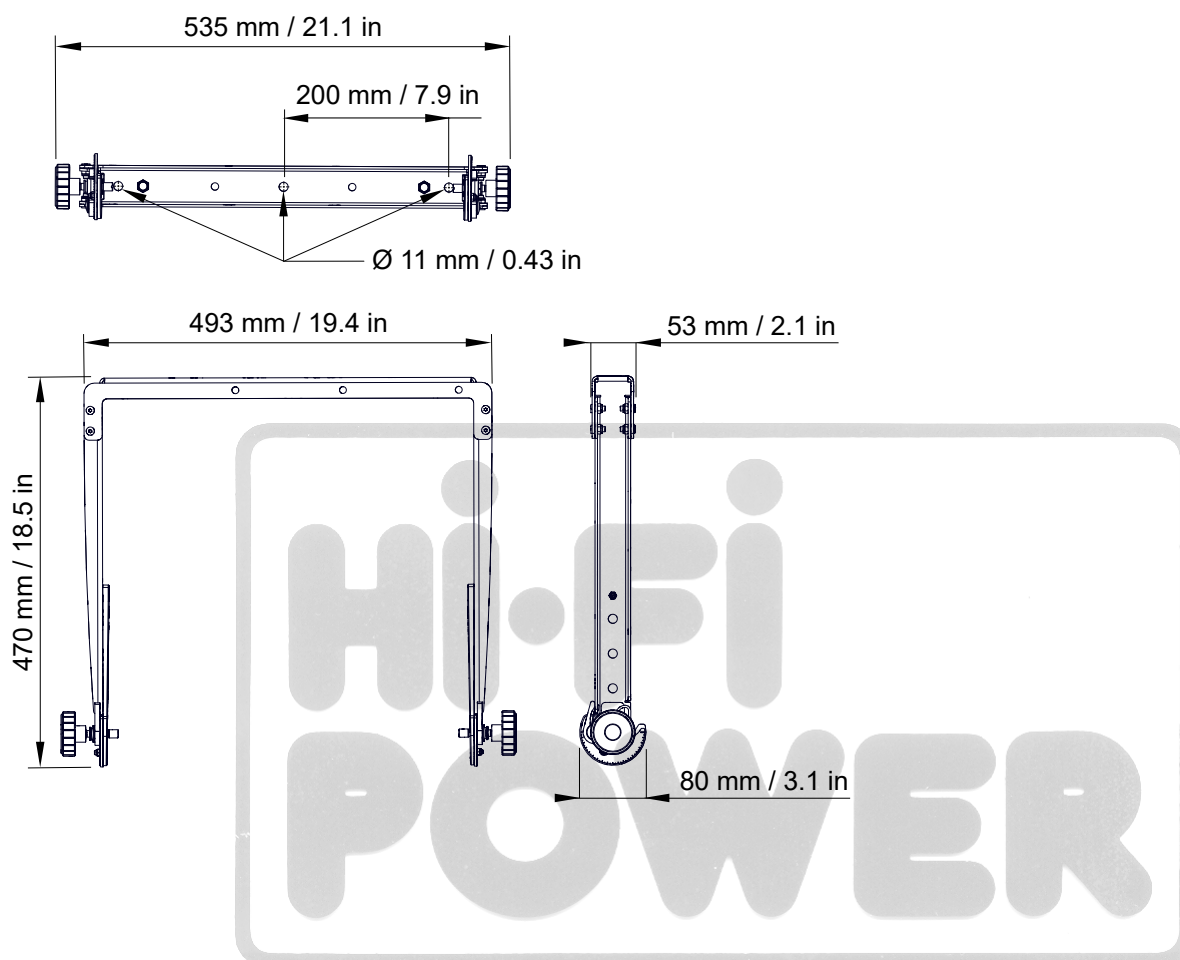

X-BAR specifications

Description	Rigging bar for 1 enclosure 1 x Ø12 mm shackle WLL 1 t
Weight (net)	1.1 kg / 2.4 lb
Material	high grade steel with anti-corrosion coating

X-BAR dimensions

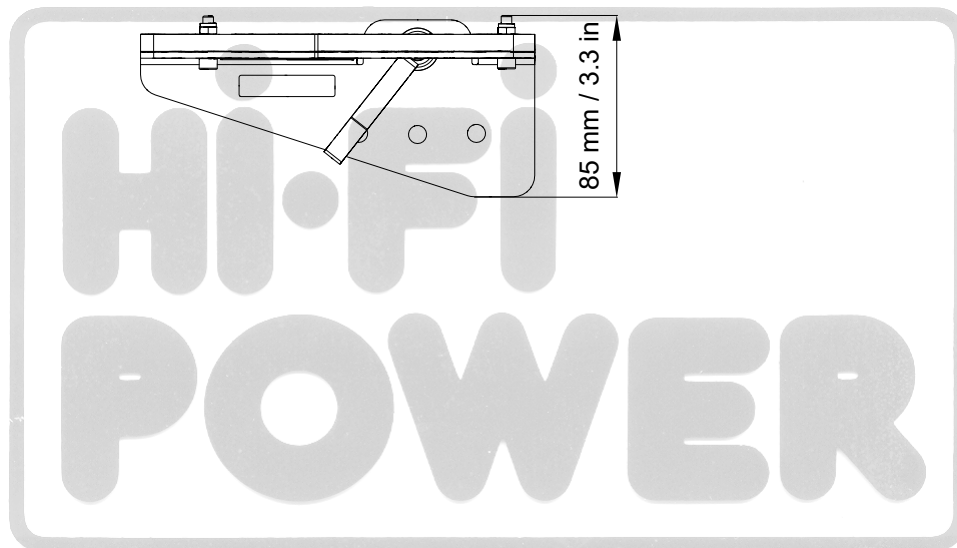
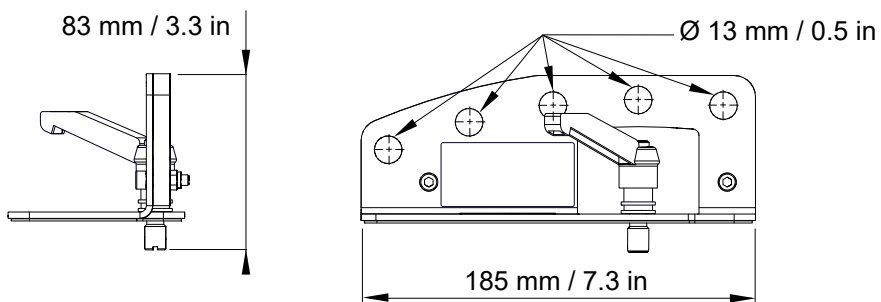

X-UTILT specifications

Description	U-bracket wallmount for X series with tilt adjustment
Weight (net)	1.5 kg / 3.3 lb
Material	high grade steel with anti-corrosion coating

X-UTILT dimensions

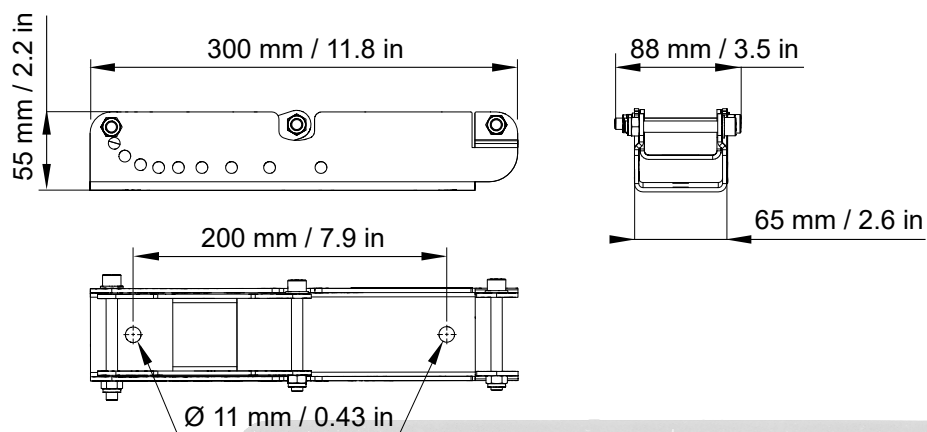

Hi-Fi
POWER

EMBi specifications

Description	Pole mount socket: 8XTi/12XTi and X series
Weight (net)	0.5 kg / 1 lb
Material	high grade steel with anti-corrosion coating

EMBi dimensions

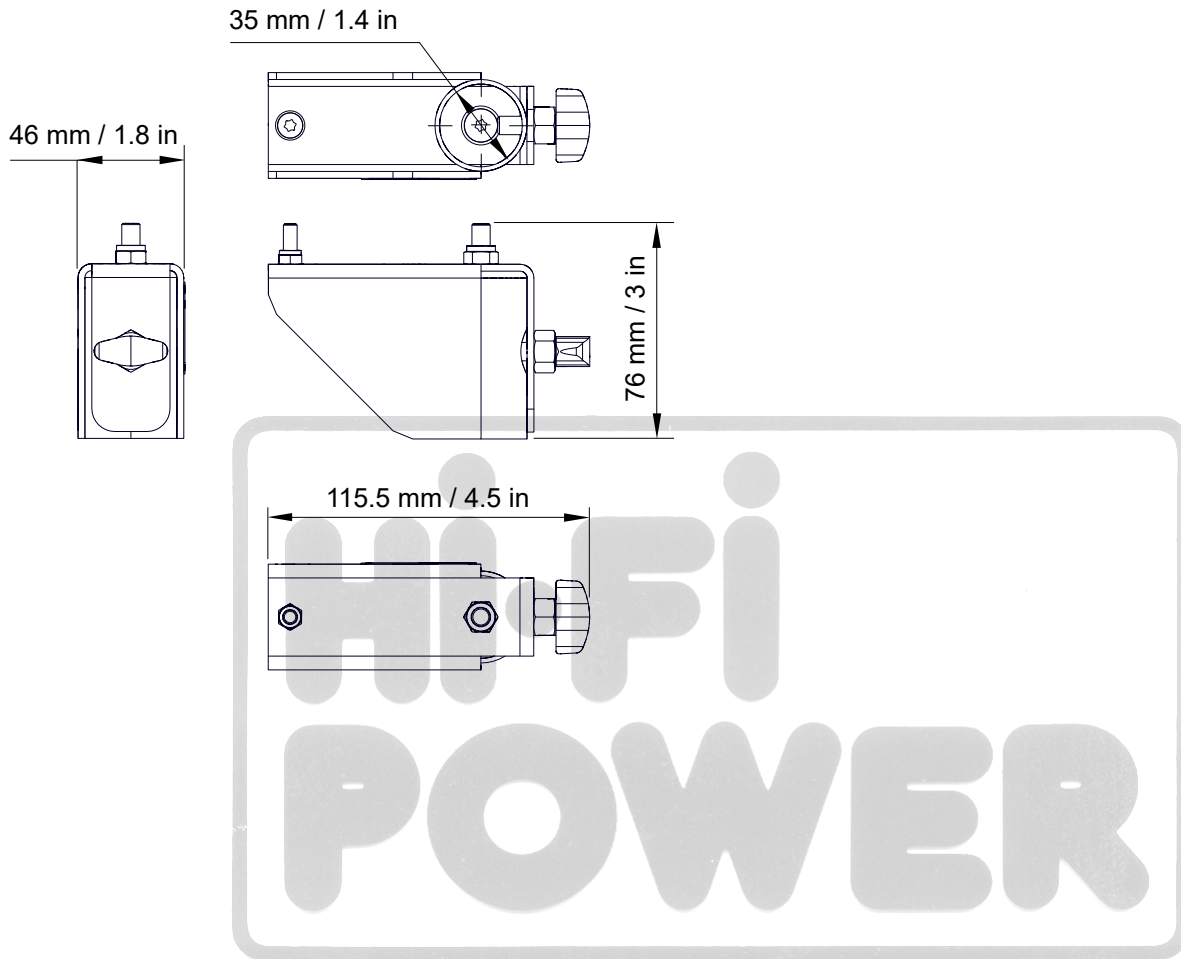

Recommendation for speaker cables

Follow the recommended maximum length for loudspeaker cables to ensure minimal SPL attenuation.

! Cable quality and resistance

Only use high-quality fully insulated speaker cables made of stranded copper wire.

Use cables with a gauge offering low resistance per unit length and keep the cables as short as possible.

The table below provides the recommended maximum length for loudspeaker cables depending on the cable gauge and on the impedance load connected to the amplifier.

cable gauge			recommended maximum length					
			8 Ω load		4 Ω load		2.7 Ω load	
mm ²	SWG	AWG	m	ft	m	ft	m	ft
2.5	15	13	30	100	15	50	10	33
4	13	11	50	160	25	80	17	53
6	11	9	74	240	37	120	25	80

Use the more detailed L-Acoustics calculation tool to evaluate cable length and gauge based on the type and number of enclosures connected. The calculation tool is available on our website:

<https://www.l-acoustics.com/installation-tools/>





L-Acoustics

13 rue Levacher Cintrat - 91460 Marcoussis - France

+33 1 69 63 69 63 - info@l-acoustics.com

www.l-acoustics.com



LACOUSTICS
GROUP



HOME &
PROFESSIONAL
AUDIOVISUAL

• MAPNH 8 ΑΘΗΝΑ 10433 • ΤΗΛ. 210 3845676 – 210 3845272 FAX. 210 3809747 • e-mail: sales@hifipower.gr •