

SB 18 Ili

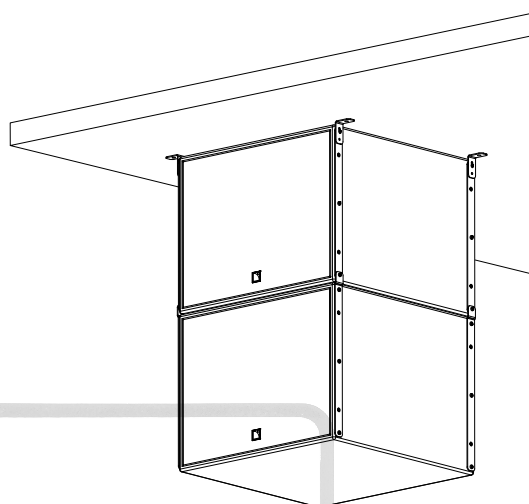

owner's manual (EN)

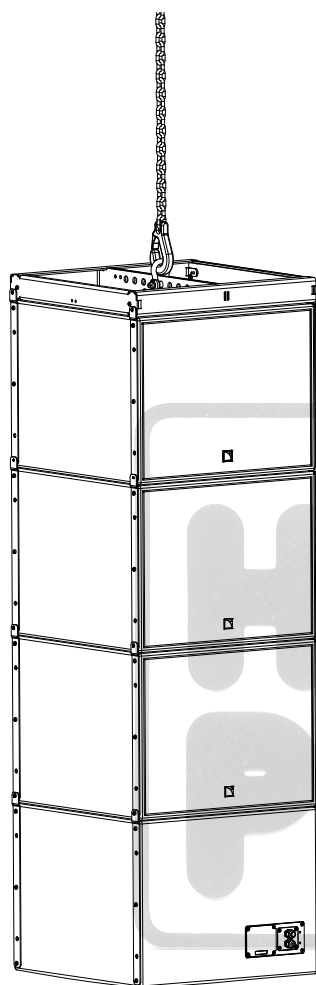

Hi-Fi
POWER

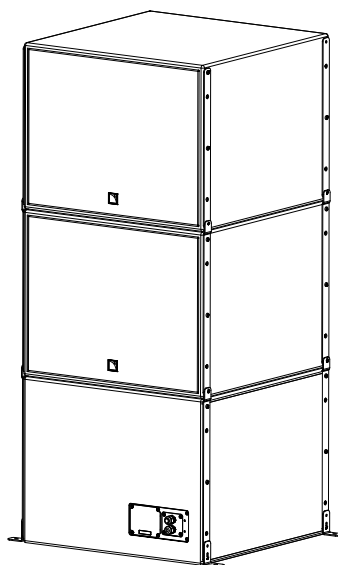

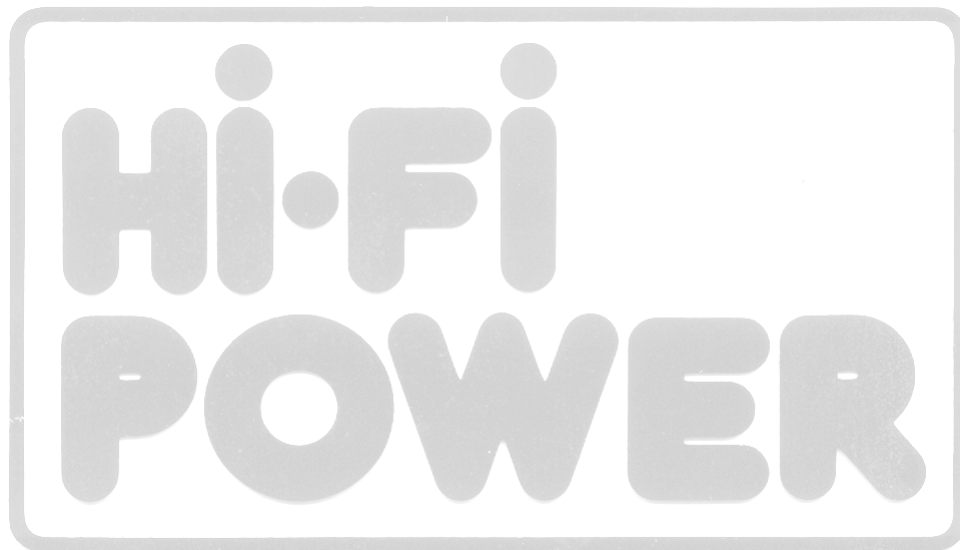

Document reference: SB18 Ili owner's manual (EN) version 3.0

Distribution date: September 5, 2022

© 2022 L-Acoustics. All rights reserved.

No part of this publication may be reproduced or transmitted in any form or by any means without the express written consent of the publisher.

Contents

Safety.....	5
Instructions.....	5
Introduction.....	7
SB18 Ili.....	7
How to use this manual.....	7
Revision history.....	8
System components.....	8
System component illustrations.....	9
Electro-acoustical description.....	11
Preset description.....	11
Connectors.....	11
Rigging system description.....	12
SB18 Ili.....	12
Rigging elements.....	13
KARAlli-BUMP.....	13
KARAlli-RIGBAR.....	14
M-BARi.....	17
KARAlli-FIXBRACKET.....	18
Front screens.....	19
Mechanical safety.....	22
Loudspeaker configurations.....	24
SB18 Ili in standard configuration.....	24
SB18 Ili in cardioid configuration.....	25
Inspection and preventive maintenance.....	26
How to do preventive maintenance.....	26
Rigging part inspection.....	27
Mechanical system overview.....	27
Acoustical check.....	30
Rigging procedures.....	33
General principles.....	33
Flying.....	34
Flying an array with KARAlli-BUMP.....	34
Flying an array with KARAlli-RIGBAR.....	39

Adding a pullback with KARAlli-RIGBAR.....	41
Ceiling-mounting.....	43
Mounting an array with KARAlli-FIXBRACKET.....	43
Stacking.....	48
Stacking an array with KARAlli-FIXBRACKET.....	48
Securing a screen.....	52
Connection to LA amplified controllers.....	54
Cabling schemes.....	55
Cabling SB18 Ili.....	57
Corrective maintenance.....	61
Introduction.....	61
Tools.....	61
SB18 Ili.....	62
SB18 Ili exploded view.....	63
Disassembly and Reassembly procedures.....	64
Specifications.....	73
APPENDIX A: Recommendation for speaker cables.....	79
APPENDIX B: Specifications for custom rigging systems.....	80

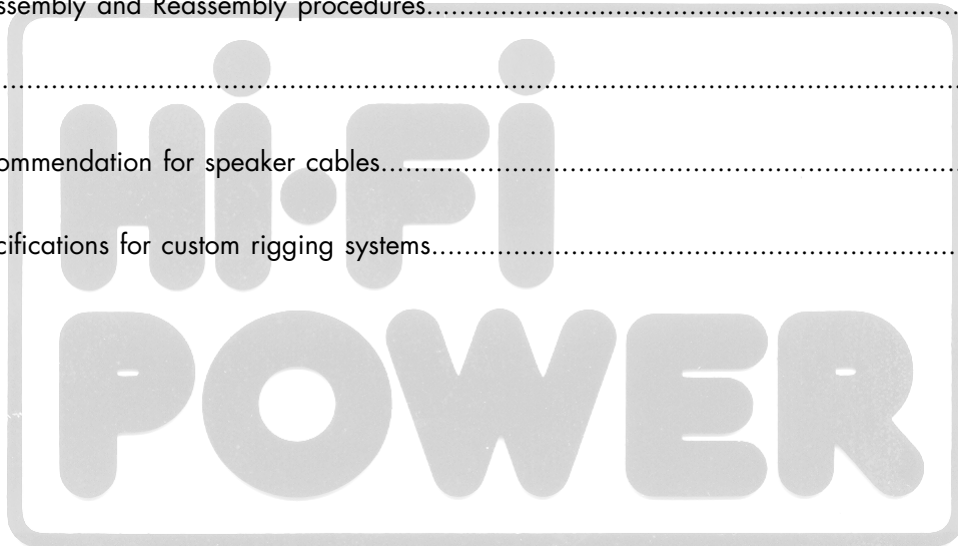

Safety

Instructions

- ! Inspect the system before any deployment.**
Perform safety related checks and inspections before any deployment.
- Perform preventive maintenance at least once a year.**
Refer to the preventive maintenance section for a list of actions and their periodicity.
Insufficient upkeep of the product can void the warranty.
- If any safety issue is detected during inspection, do not use the product before performing corrective maintenance.**
Check for issues. A rigging system part or fastener is missing or loose. A rigging system part exhibits: bends, breaks, broken parts, corrosion, cracks, cracks in welded joints, deformation, denting, wear, holes. A safety cue or label is missing.
- ! Never incorporate equipment or accessories not approved by L-Acoustics.**
- ! Read all the related PRODUCT INFORMATION documents shipped with the products before exploiting the system.**
- ! Do not store the product on an unstable cart, stand, tripod, bracket, or table.**
- ! Beware of sound levels.**
Do not stay within close proximity of loudspeakers in operation.
Loudspeaker systems are capable of producing very high sound pressure levels (SPL) which can instantaneously lead to permanent hearing damage to performers, production crew and audience members. Hearing damage can also occur at moderate level with prolonged exposure to sound.
Check the applicable laws and regulations relating to maximum sound levels and exposure times.
- ! Work with qualified personnel for rigging the system.**
Installation should only be carried out by qualified personnel that are familiar with the rigging techniques and safety recommendations outlined in this manual.
- Ensure personnel health and safety.**
During installation and set-up personnel must wear protective headgear and footwear at all times. Under no circumstances is personnel allowed to climb on a loudspeaker assembly.
- Respect the Working Load Limit (WLL) of third party equipment.**
L-Acoustics is not responsible for any rigging equipment and accessories provided by third party manufacturers. Verify that the Working Load Limit (WLL) of the suspension points, chain hoists and all additional hardware rigging accessories is respected.
- Respect the maximum configurations and the recommended safety precautions.**
For safety issue, respect the maximum configurations outlined in this manual. To check the conformity of any configuration in regards with the safety precautions recommended by L-Acoustics, model the system in Soundvision and refer to the warnings in Mechanical Data section.
- Be cautious when flying a loudspeaker configuration.**
Before installing/raising the product, check each individual element to make sure that it is securely fastened to the adjacent element. Always verify that no one is standing underneath the product when it is being installed/raised. Never leave the product unattended during the installation process.
As a general rule, L-Acoustics recommends the use of secondary safety at all times.
- Be cautious when ground-stacking a loudspeaker array.**
Do not stack the loudspeaker array on unstable ground or surface. If the array is stacked on a structure, platform, or stage, always check that the latter can support the total weight of the array.
As a general rule, L-Acoustics recommends the use of safety straps at all times.

Risk of falling objects

Verify that no unattached items remain on the product or assembly.

Risk of tipping

Remove all rigging accessories before transporting a product or an assembly.

Take into account the wind effects on dynamic load.

When a loudspeaker assembly is deployed in an open air environment, wind can produce dynamic stress to the rigging components and suspension points.

If the wind force exceeds 6 bft (Beaufort scale), lower down and/or secure the product or the assembly.



Intended use

This system is intended for use by trained personnel for professional applications.



As part of a continuous evolution of techniques and standards, L-Acoustics reserves the right to change the specifications of its products and the content of its documents without prior notice.

Check www.l-acoustics.com on a regular basis to download the latest document and software updates.



Long term exposure to extreme conditions may damage the product.

For more information, refer to the **Products weather protection** document, available on the website.



Read the maintenance section of this document before servicing the product.



Contact L-Acoustics for advanced maintenance.

Any unauthorized maintenance operation will void the product warranty.



This marking indicates that this product should not be disposed of with other household waste throughout the EU. To prevent possible harm to the environment or human health from uncontrolled waste disposal, recycle it responsibly to promote the sustainable reuse of material resources. To return your used device, please use the return and collection systems or contact the retailer where the product was purchased. They can take this product for environmentally safe recycling.

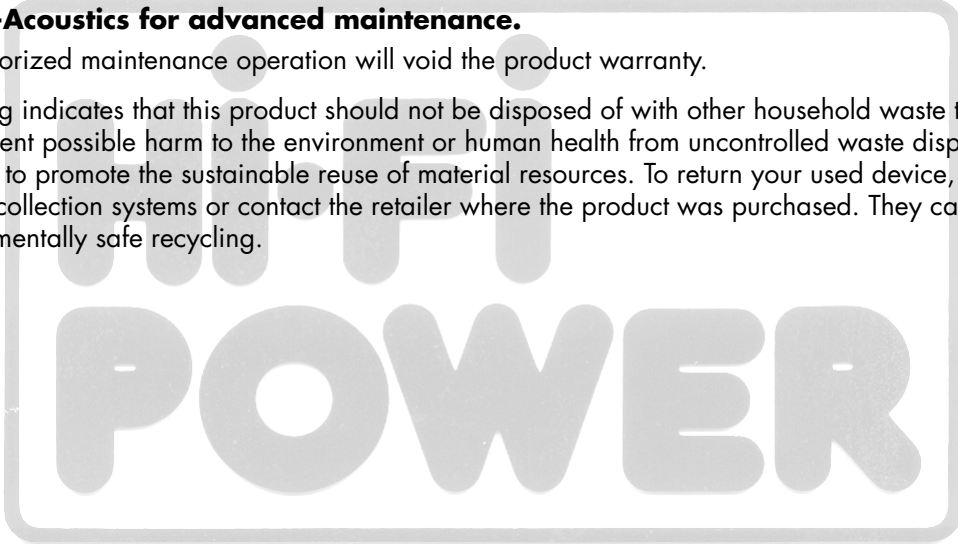

Introduction

SB18 Ili

SB18 Ili is a compact subwoofer designed to extend the bandwidth of the Kara Ili system in installation applications. It features one high-excursion, direct-radiating 18" transducer mounted in a dual bass-reflex tuned enclosure.

SB18 Ili can be coupled mechanically and acoustically with Kara Ili to reinforce contour and extend bandwidth to 32 Hz. The subwoofer features L-Vents that substantially reduce turbulence and port noise at high levels while also increasing LF efficiency.

The SB18 Ili frequency response is optimized to couple perfectly with Kara Ili, in flown or stacked configurations, and to extend the bandwidth of X Series loudspeakers.

SB18 Ili can be deployed in standard or cardioid configurations with dedicated presets.

How to use this manual

The SB18 Ili owner's manual is intended for all actors involved in the system design, implementation, preventive and corrective maintenance of the SB18 Ili system. It must be used as follows:

1. Read the technical description for an overview of all system elements, their features, and their compatibilities.
 - [Electro-acoustical description](#) (p.11)
 - [Rigging system description](#) (p.12)
2. Prepare the system configuration. Consider the mechanical limits and the available acoustical configurations.
 - [Mechanical safety](#) (p.22)
 - [Loudspeaker configurations](#) (p.24)
3. Before rigging the system, perform mandatory inspections and functional checks.
 - [Inspection and preventive maintenance](#) (p.26)
4. To deploy the system, follow the step-by-step rigging instructions and refer to the cabling schemes.
 - [Rigging procedures](#) (p.33)
 - [Connection to LA amplified controllers](#) (p.54)

 The [Corrective maintenance](#) (p.61) section contains the operations authorized for the end user. Performing another operation exposes to hazardous situations. For advanced maintenance, contact your L-Acoustics representative.

As part of a continuous evolution of techniques and standards, L-Acoustics reserves the right to change the specifications of its products and the content of its document without prior notice. Please check www.l-acoustics.com on a regular basis to download the latest document and software updates.

Contact information

For information on advanced corrective maintenance:

- contact your Certified Provider or your L-Acoustics representative
- for Certified Providers, contact the L-Acoustics customer service: customer.service@l-acoustics.com (EMEA/APAC), laus.service@l-acoustics.com (Americas).

Symbols

The following symbols are used in this document:

 This symbol indicates a potential risk of harm to an individual or damage to the product. It can also notify the user about instructions that must be strictly followed to ensure safe installation or operation of the product.

 This symbol notifies the user about instructions that must be strictly followed to ensure proper installation or operation of the product.

 This symbol notifies the user about complementary information or optional instructions.

Revision history

version number	publication date	modification
1.0	Mar. 2021	Initial version.
2.0	Jun. 2021	Added Inspection and preventive maintenance section.
3.0	Sep. 2022	Updated Specifications for custom rigging systems (p.80).

System components

Loudspeaker enclosures

SB18 Ili High power compact subwoofer: 1 x 18" (installation version)

Powering and driving system

LA2Xi / LA4X / LA8 / LA12X Amplified controller with DSP, preset library and networking capabilities

 Refer to the LA2Xi / LA4X / LA8 / LA12X owner's manual for operating instructions.

Cables

2 x 2.5 mm² cable speaker cable with bare wire endings
Adapt the cable length to the installation.

custom 4-point speakON cable 4-point speakON cable (2.5 mm² gauge) to bare wire cable
This cable needs to be custom made.

 **Information about the connection of the enclosures to the LA amplified controllers is given in this document.**

Refer to the LA2Xi / LA4X / LA8 / LA12X owner's manual for detailed instructions about the whole cabling scheme, including modulation cables and network.

Rigging elements

SB18Ili-LINK Rigging plates for SB18 Ili

SB18Ili-ENDLINK End rigging plates for SB18 Ili

KARAIli-FIXBRACKET Fastening brackets for Kara Ili and SB18 Ili

KARAIli-BUMP Flying frame for vertical deployment of Kara Ili and SB18 Ili

KARAIi-RIGBAR	Rigging bar and pullback for Kara Ili and SB18 Ili
M-BARi	Extension bar for rigging frame (installation version)
CLAMP250	Clamp certified for 250 kg

Screens

SB18Ili-SCREEN	Acoustically transparent front screen for SB18 Ili
----------------	--

Software applications

Soundvision	3D acoustical and mechanical modeling software
LA Network Manager	Software for remote control and monitoring of amplified controllers



Refer to the **Soundvision** help.

Refer to the **LA Network Manager** help.

System component illustrations

Cables

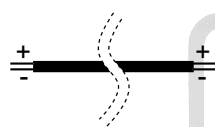

2 x 2.5 mm² cable

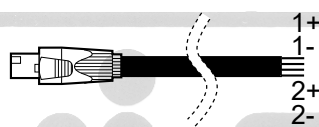

custom 4-point speakON cable

Rigging accessories

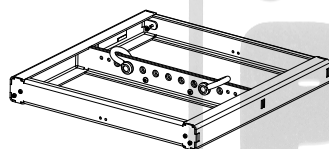

KARAIi-BUMP

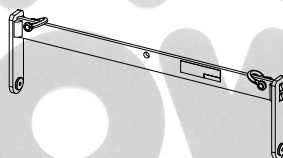

KARAIi-RIGBAR

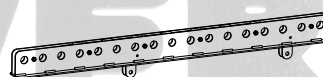

M-BARi

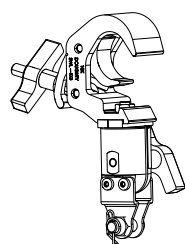

CLAMP250

Rigging plates

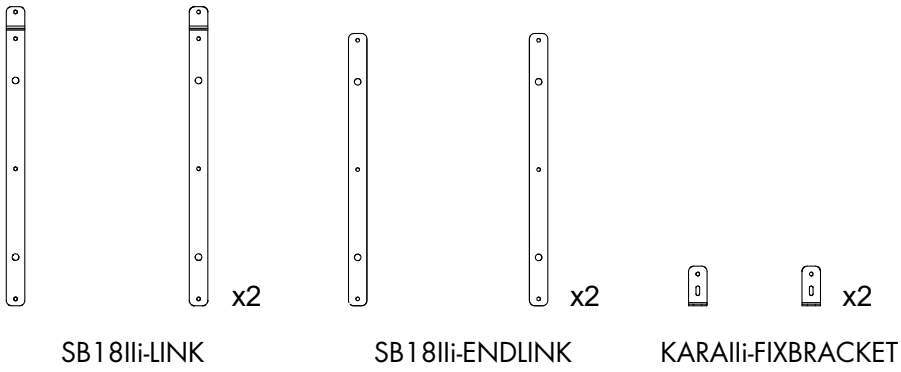

Screens

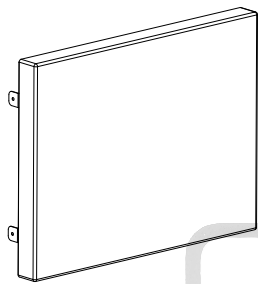

SB18Ili-SCREEN

Software applications

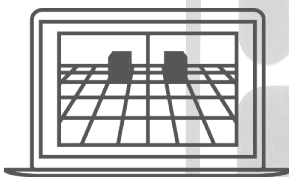

Soundvision



LA Network Manager



Electro-acoustical description

Preset description

[SB18_60] [SB18_100]

outputs	channels	routing	gain	delay	polarity	mute
OUT 1	SB	IN A	0 dB	0 ms	+	ON
OUT 2	SB	IN A	0 dB	0 ms	+	ON
OUT 3	SB	IN A	0 dB	0 ms	+	ON
OUT 4	SB	IN A	0 dB	0 ms	+	ON

[SB18_60_C] [SB18_100_C] [SB18_60_Cx] [SB18_100_Cx]

loudspeaker elements	outputs	channels	routing	gain	delay	polarity	mute
SR	OUT 1	SR	IN A	0 dB	0 ms	+	ON
SB	OUT 2	SB					ON
SB	OUT 3	SB					ON
SB	OUT 4	SB					ON

Connectors

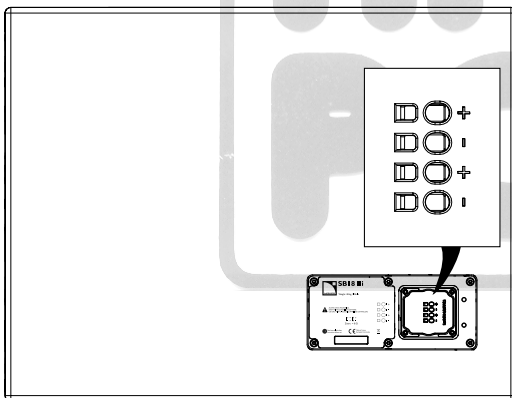

SB18 IIi

1 x 4-point terminal block with push-in connection

Internal pinout for L-Acoustics subwoofers

Terminal block points	IN +	IN -
Transducer connectors	LF +	LF -

Rigging system description

SB18 Ili

SB18 Ili is the dedicated subwoofer for Kara Ili.

SB18 Ili is compatible with two types of rigging kits:

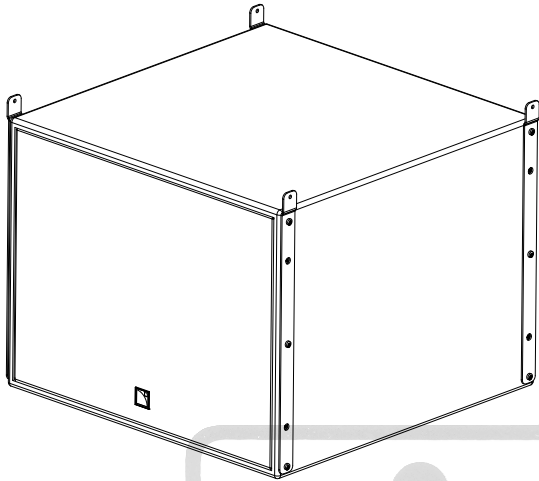

standard rigging plates (SB18Ili-LINK)

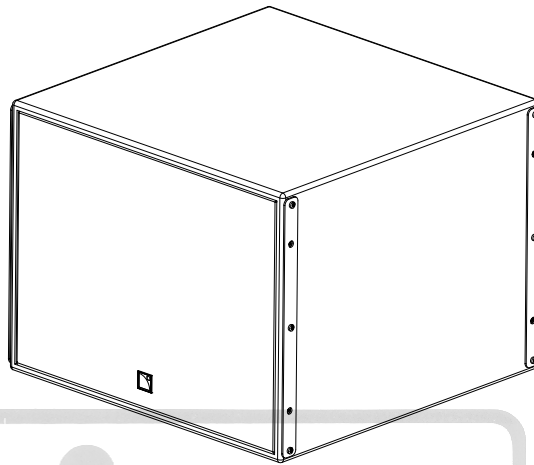

end rigging plates (SB18Ili-ENDLINK)

SB18 Ili features ten M6 inserts on each side:

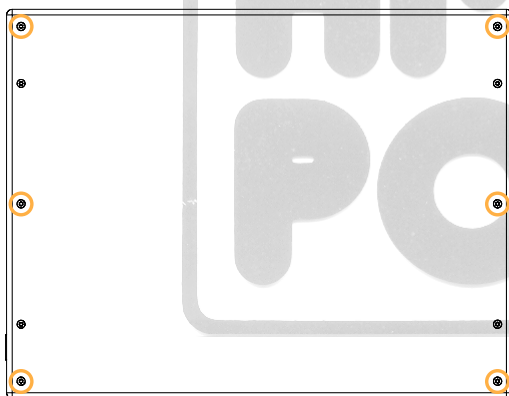

Six M6 inserts for rigging



Four M6 inserts for securing a screen in standard or cardioid configurations

Refer to [Securing a screen](#) (p.52).

The inserts are fitted with placeholder screws.

! Rigging screws

Only use the rigging screws provided by L-Acoustics.
Do not use the placeholder screws for rigging.

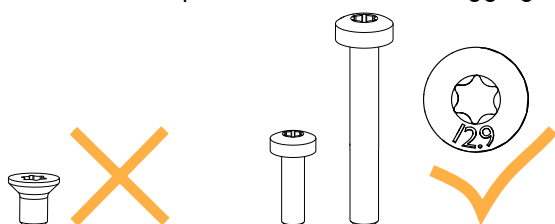

 Always put the placeholder screws back in place to avoid leaks.

Rigging elements

KARAlli-BUMP

KARAlli-BUMP is a rigging frame for flying arrays of SB18 Ili.

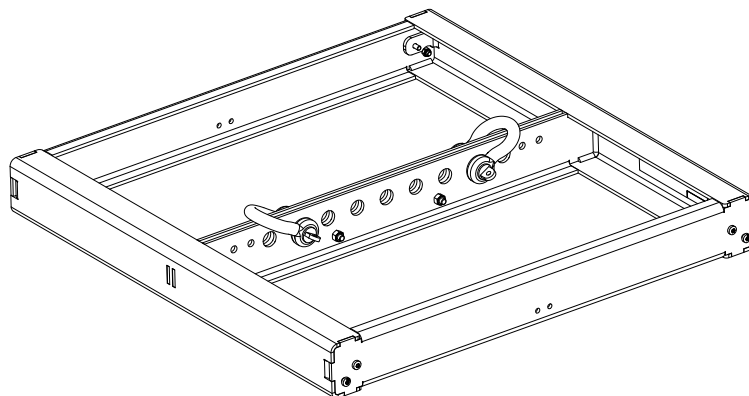

KARAlli-BUMP can be used as the main lifting accessory for flying vertical arrays of SB18 Ili with one or two lifting points.

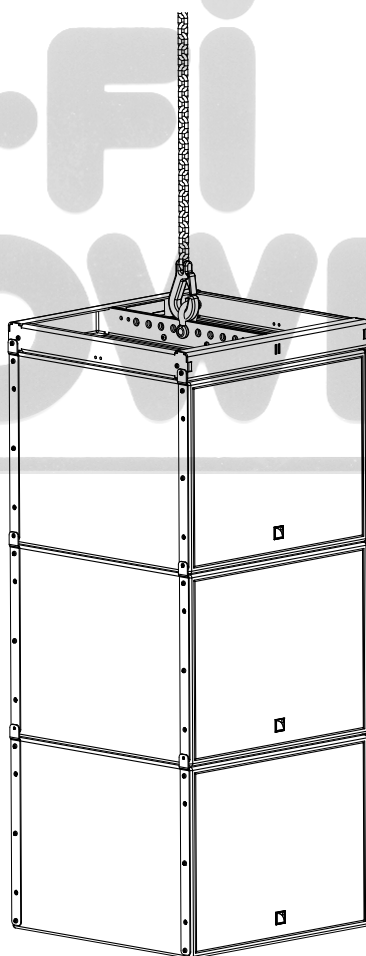

KARAIi-BUMP is secured to the array with four M6x18 screws and M6 nuts (provided).

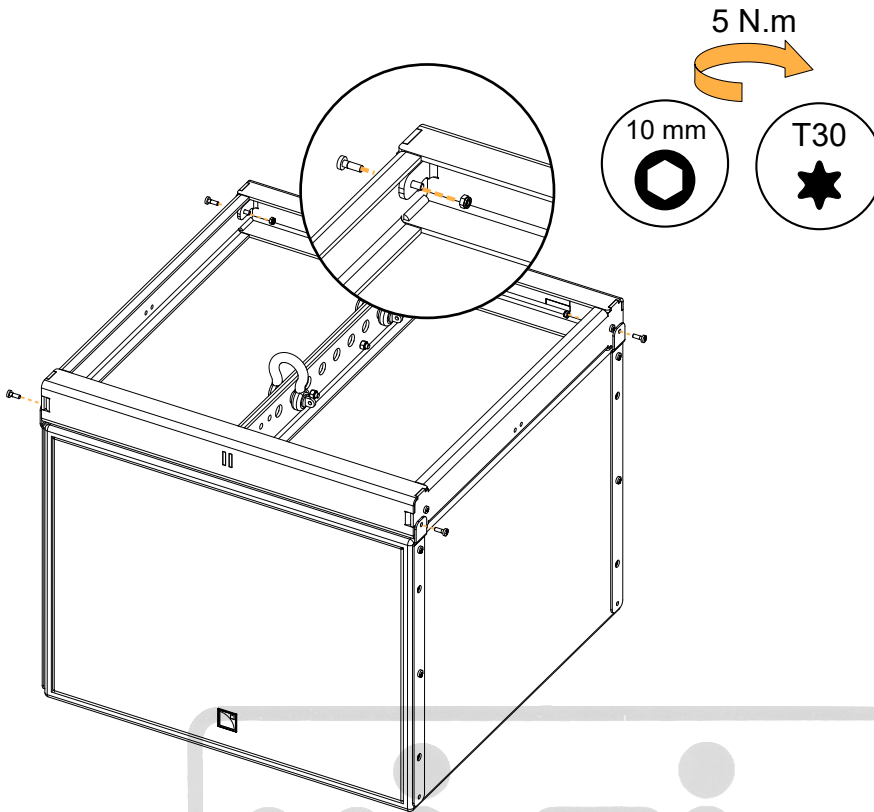

Nine pickup points are available on the central bar for site angle adjustment. They are compatible with Ø19 mm shackles WLL 3.25 t (two provided). Four holes are available to secure M-BARi in position A or B, to provide additional pickup points. Refer to [M-BARi](#) (p.17).

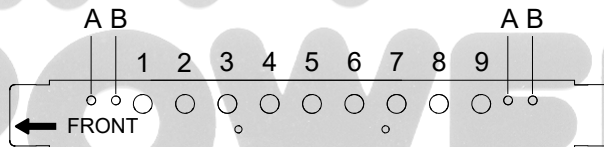

KARAIi-RIGBAR

KARAIi-RIGBAR is a rigging bar for pullback configurations of SB18 Ili arrays.

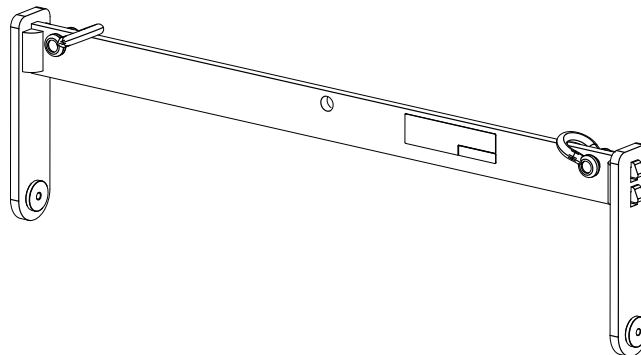

Secured at the bottom of the array, KARAlli-RIGBAR can be used as a pullback with another KARAlli-RIGBAR as the main lifting accessory. With KARAlli-RIGBAR as the main lifting accessory, SB18li-ENDLINK is required on the top enclosure.

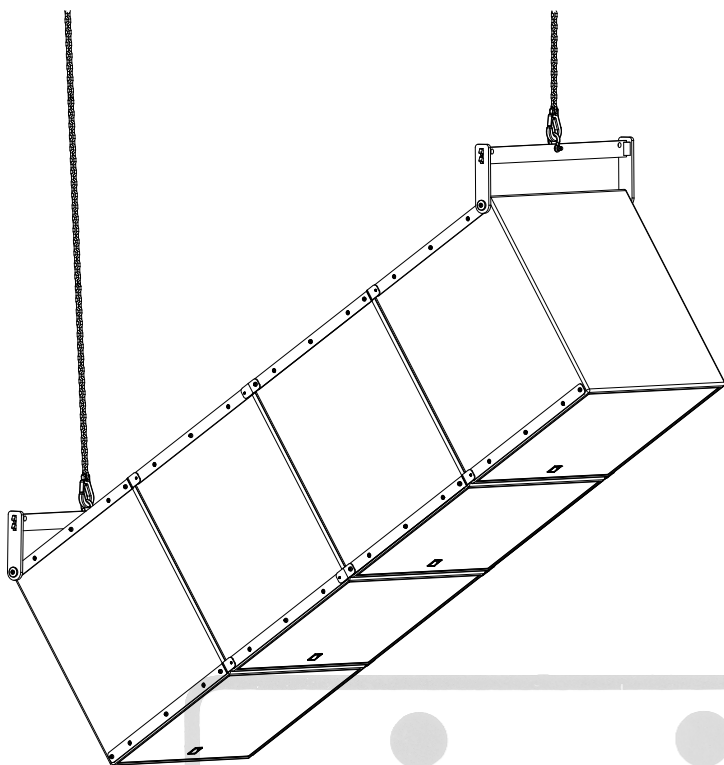

KARAlli-RIGBAR can be secured at the front for an initial positive site angle.

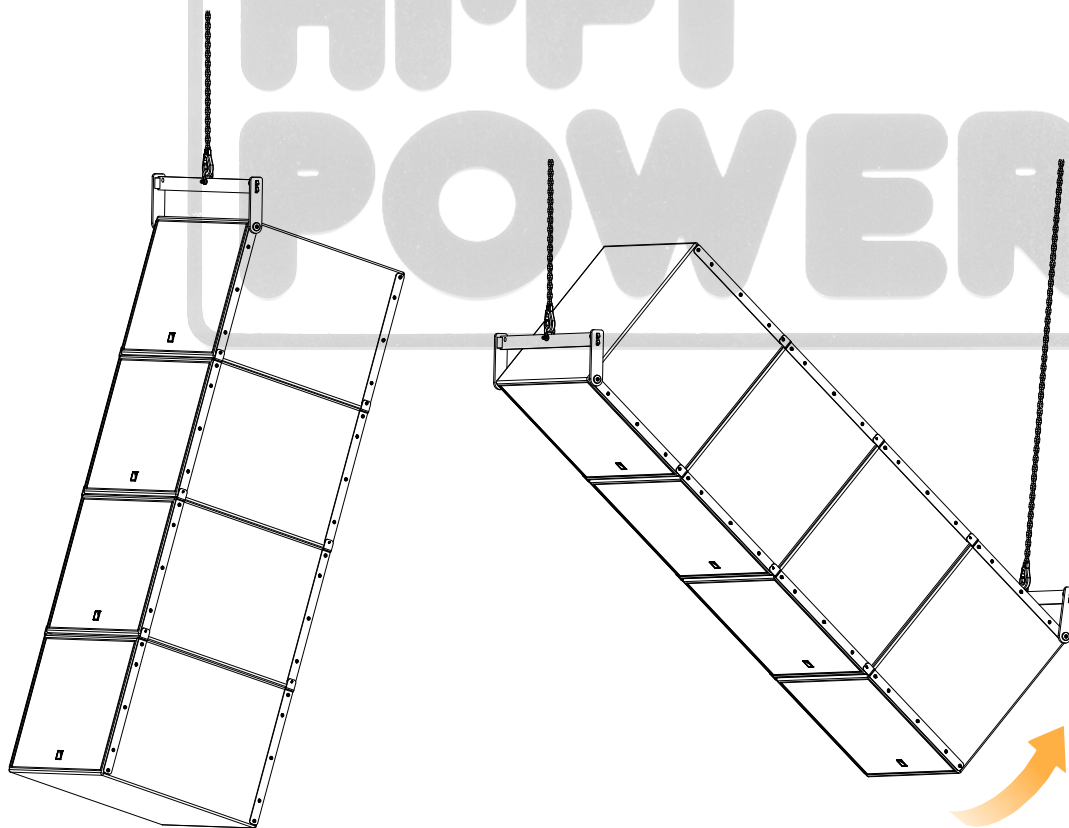

KARAlli-RIGBAR is secured to the enclosure with two M6x40 screws (provided).

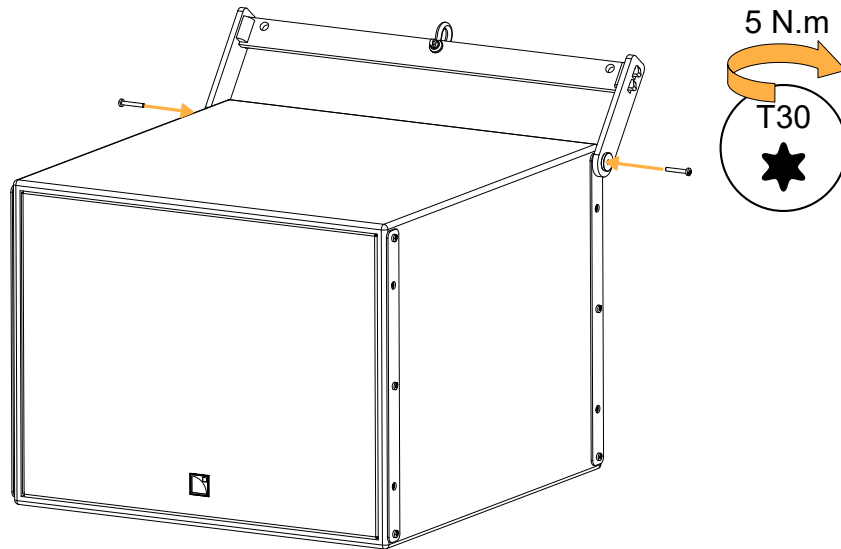

The pickup points are compatible with Ø12 mm shackles WLL 1 t (two provided) and CLAMP250.

! Maximum limit with CLAMP250.
 CLAMP250 has a WLL (Working Load Limit) of 250 kg / 550 lb. It can support an array of up to 5 SB18 Ili. For an hybrid array, check the total weight of the array in Soundvision.
 For more information, refer to the **CLAMP250 owner's manual**.

! When using KARAlli-RIGBAR as the main lifting accessory, always implement a secondary safety using available holes.

One pickup point

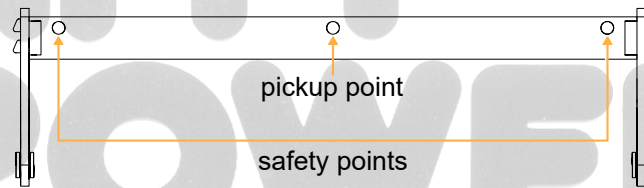

Two pickup points

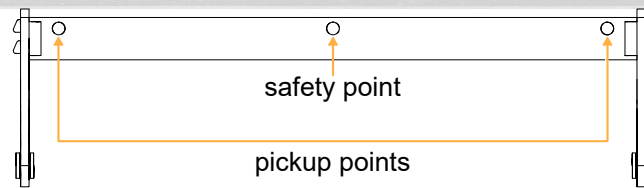

M-BARi

The M-BARi extension bar can be secured on KARAlli-BUMP to extend the site angle capability of SB18 Ili arrays. It can be used as a front or rear extension, with two possible positions each (A or B).

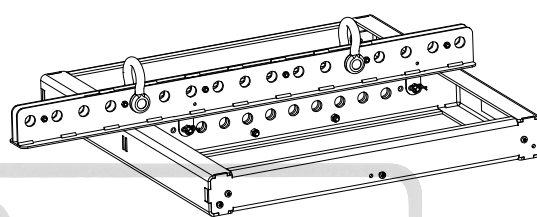
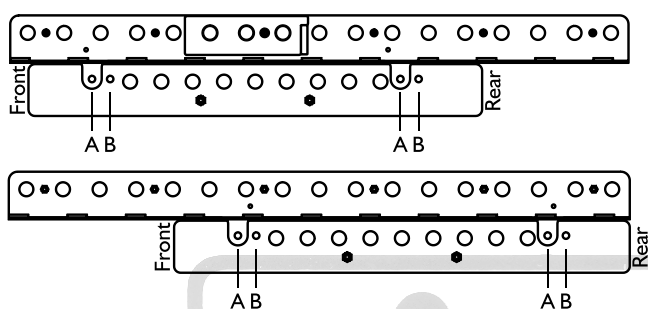
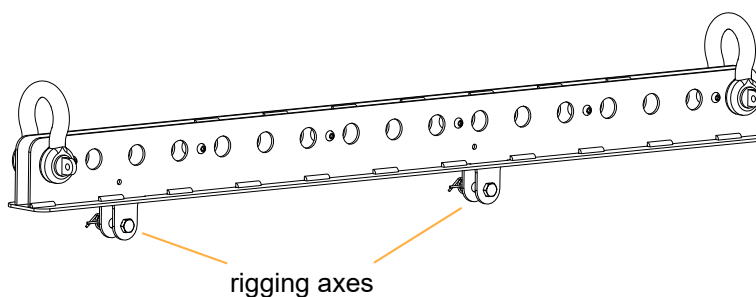

M-BARi is secured to the rigging frame with two M8 bolts, nuts, and safety pins.

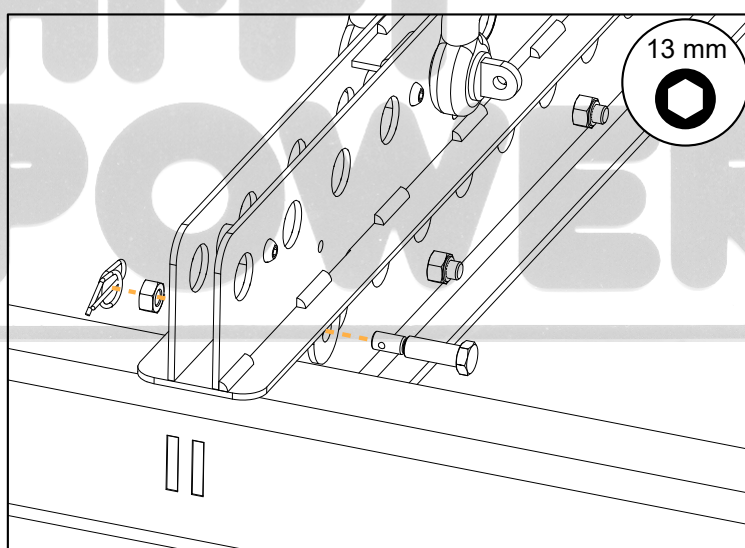

Seventeen (17) pickup points are available. They are compatible with Ø19 mm shackles WLL 3.25 t (two provided).

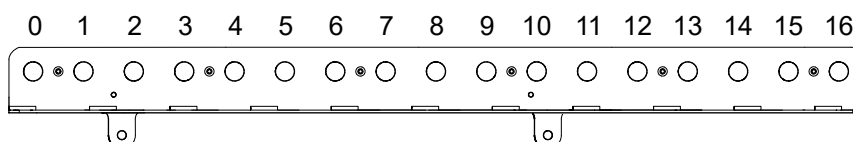

KARAIi-FIXBRACKET

KARAIi-FIXBRACKET is a set of four fastening brackets for SB18 Ili. The enclosure is secured to KARAIi-FIXBRACKET using the slotted hole.

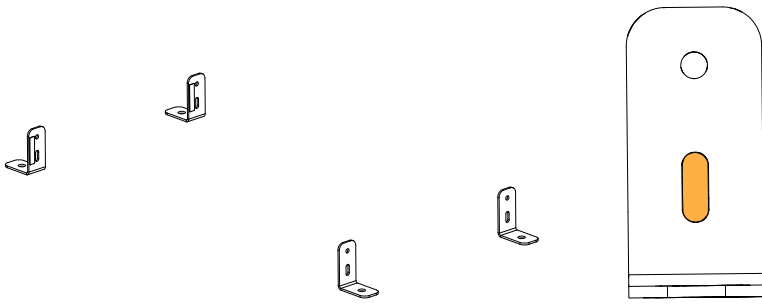

Secure KARAIi-FIXBRACKET at the bottom of an array to improve stability and to anchor it to the ground.

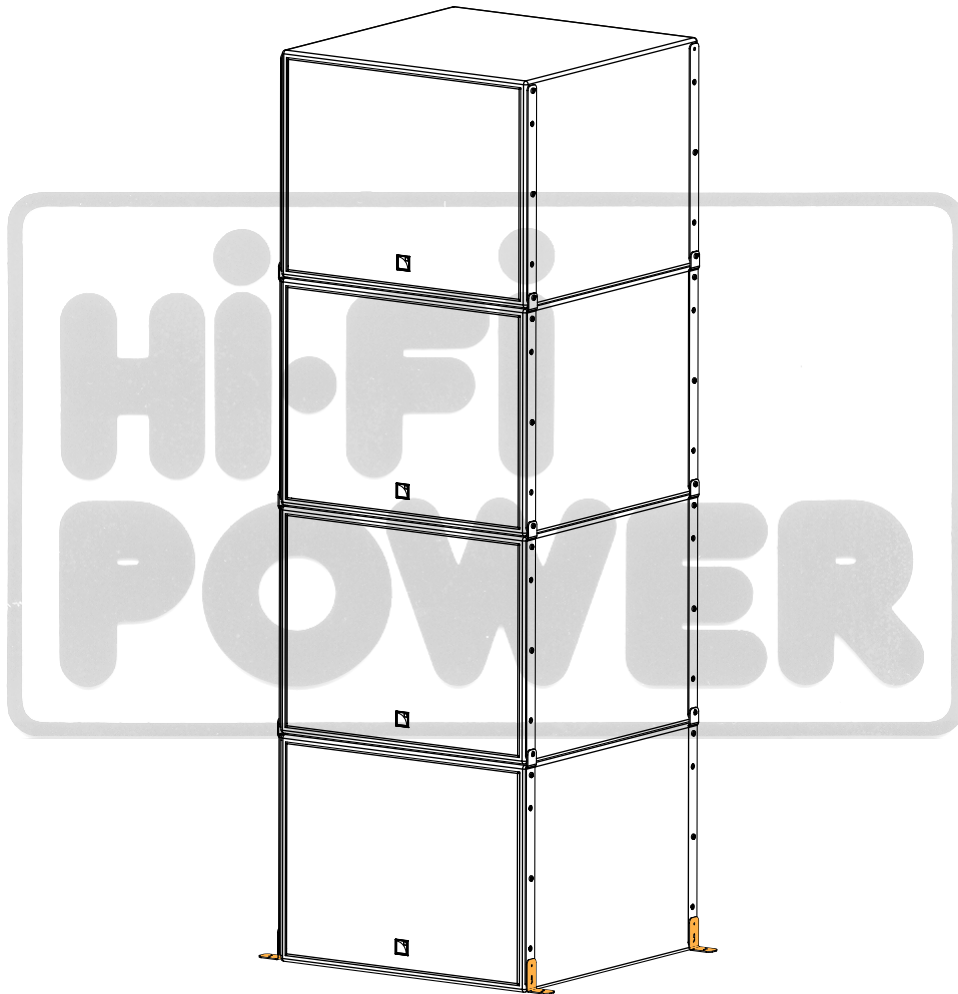

KARAIi-FIXBRACKET can also be used to mount up to two SB18 Ili under the ceiling.

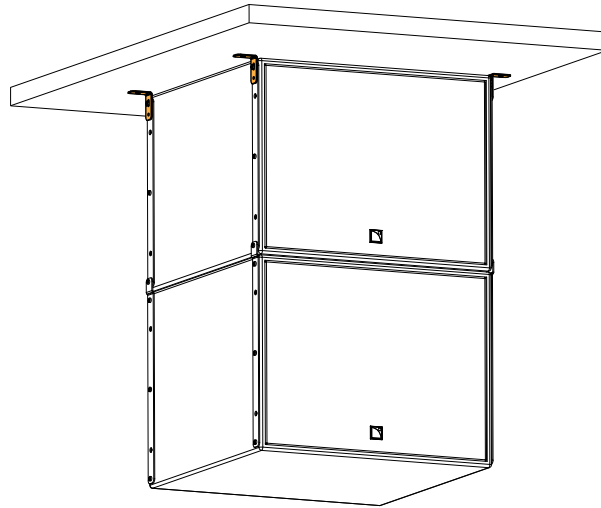

KARAIi-FIXBRACKET must be secured to the supporting fixture with four M10 screws.



Fasteners for ceiling-mounting

Select screw length and anchors applicable to the ceiling properties.

Model the array in Soundvision and check the loads on rigging in the **Mechanics view**.

Front screens

SB18Ii-SCREEN is an acoustically transparent front screen for SB18 Ili.

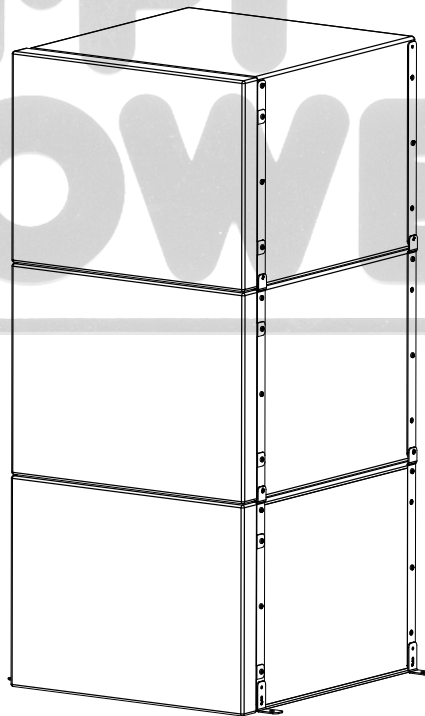

The screens are secured on top of the rigging plates with four M6×35 Torx screws which replace the grill screws. The grill screws can be removed through the rigging plates.

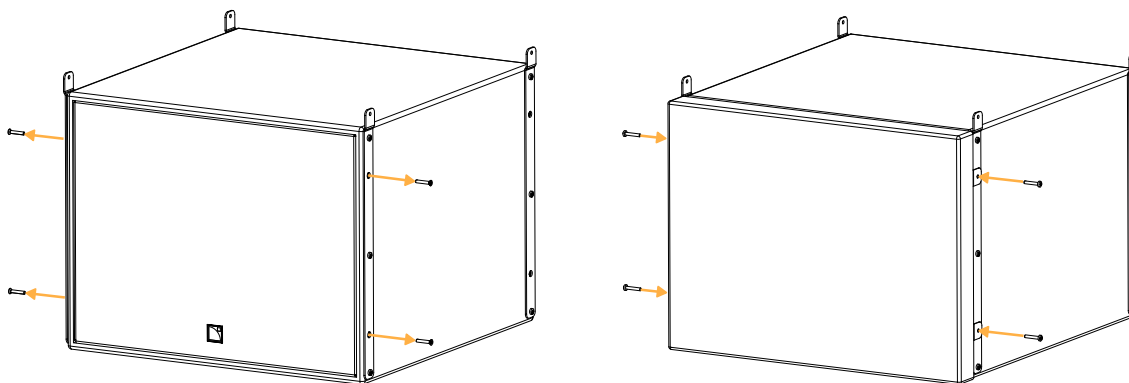

The screens are equipped with tabs to hold the grill in place when securing the screen on the enclosure.

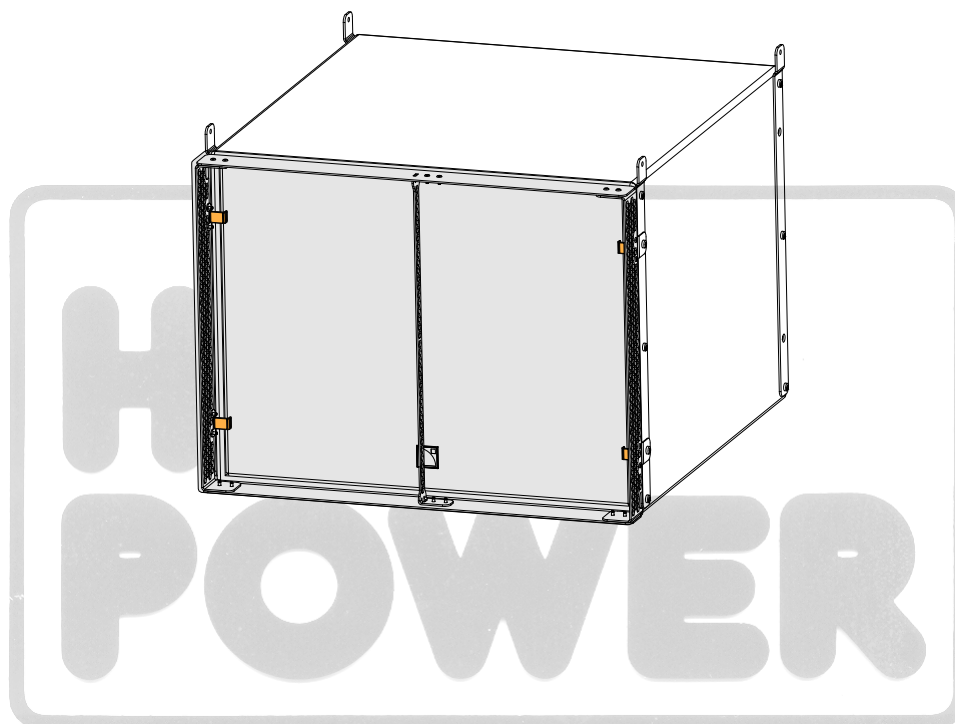

SB18Ili-SCREEN can be secured to the back of SB18 Ili when used in cardioid configuration. The cable(s) can be passed through a cutout on the screen side.

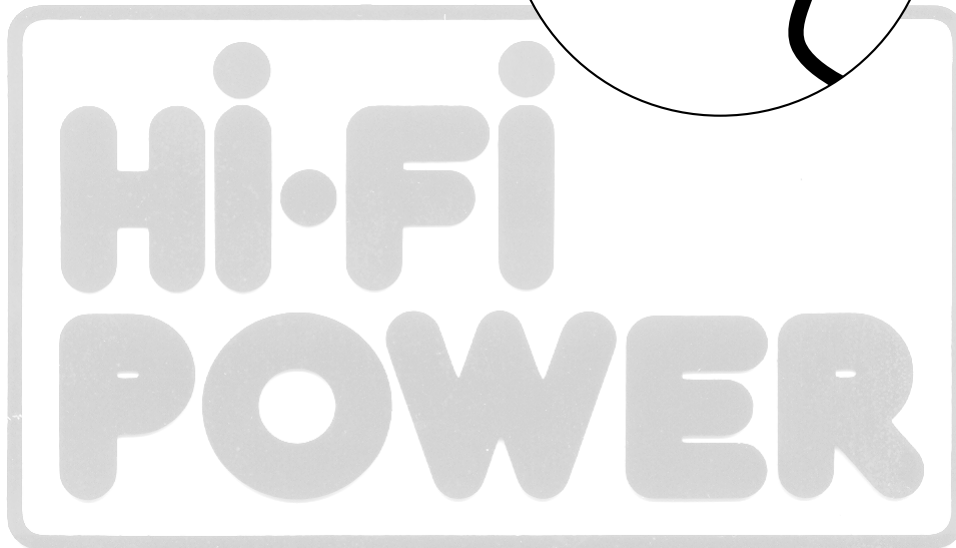
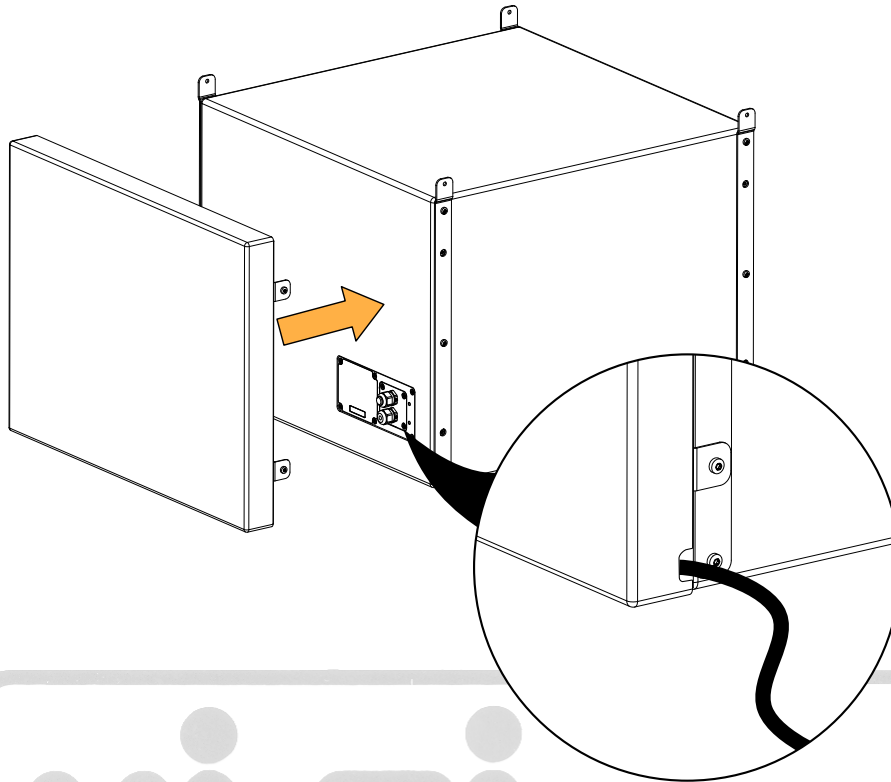

Mechanical safety

Flown configurations

The SB18 Ili rigging system complies with 2006/42/EC: Machinery Directive. It has been designed following the guidelines of BGV-C1.

2006/42/EC: Machinery Directive specifies a safety factor of 4 against the rupture. The flown deployments described in this manual achieve a safety factor of **4 or more**.

Refer to Soundvision for the safety factor of a specific deployment.

The **safe limit** gives the maximum number of elements for which the safety factor is compliant with the 2006/42/EC: Machinery Directive, within the use defined in this manual and regardless of the other deployment parameters (site angles, inter-element angles, etc.).

The **maximum limit** gives the maximum number of elements for which the safety factor can be compliant with the 2006/42/EC: Machinery Directive, when the other deployment parameters provide the best mechanical conditions.

For mixed arrays refer to your Soundvision model.

SB18 Ili

configuration	rigging accessory	safe limit	maximum limit
Flown	KARAlli-BUMP + rigging plates	12	16
	KARAlli-BUMP + M-BARi + rigging plates	8	16
Flown with pullback	KARAlli-BUMP + M-BARi + KARAlli-RIGBAR + rigging plates	8	12
	KARAlli-RIGBAR × 2 + rigging plates	4	6
Ceiling-mounted	KARAlli-FIXBRACKET + rigging plates	2	

Other configurations

For other configurations, respect the recommended maximum limit for optimal stability.

SB18 Ili

configuration	rigging accessory	safe/maximum limit
Stacked	KARAlli-FIXBRACKET (optional) + rigging plates	4

Assessing mechanical safety

 **Mechanical safety of the rigging system**
Before any installation, always model the system in Soundvision and check the **Mechanical Data** section for any stress warning or stability warning.

In order to assess the actual safety of any array configuration before implementation, refer to the following warnings:

 **Rated working load limit (WLL) is not enough**
The rated WLL is an indication of the element resistance to tensile stress. For complex mechanical systems such as loudspeaker arrays, WLLs cannot be used per se to determine the maximum number of enclosures within an array or to assess the safety of a specific array configuration.

Maximum pullback angle

If a pullback accessory is available, the pullback angle must not exceed a 90° negative site angle.

Mechanical modeling with Soundvision

The working load applied to each linking point, along with the corresponding safety factor, will depend on numerous variables linked to the composition of the array (type and number of enclosures, splay angles) and the implementation of the flying or stacking structure (number and location of flying points, site angle). This cannot be determined without the complex mechanical modeling and calculation offered by Soundvision.

Assessing the safety with Soundvision

The overall safety factor of a specific mechanical configuration always corresponds to the lowest safety factor among all the linking points. Always model the system configuration with the Soundvision software and check the **Mechanical Data** section to identify the weakest link and its corresponding working load. By default, a stress warning will appear when the mechanical safety goes beyond the recommended safety level.

Safety of ground-stacked arrays in Soundvision

For ground-stacked arrays, a distinct stability warning is implemented in Soundvision. It indicates a tipping hazard when the array is not secured to the ground, stage or platform. It is the user's responsibility to secure the array and to ignore the warning.

Additional safety for flown arrays

When flying an array, use available holes to implement a secondary safety.

Considerations must be given to unusual conditions

Soundvision calculations are based on usual environmental conditions. A higher safety factor is recommended with factors such as extreme high or low temperatures, strong wind, prolonged exposition to salt water, etc. Always consult a rigging specialist to adopt safety practices adapted to such a situation.

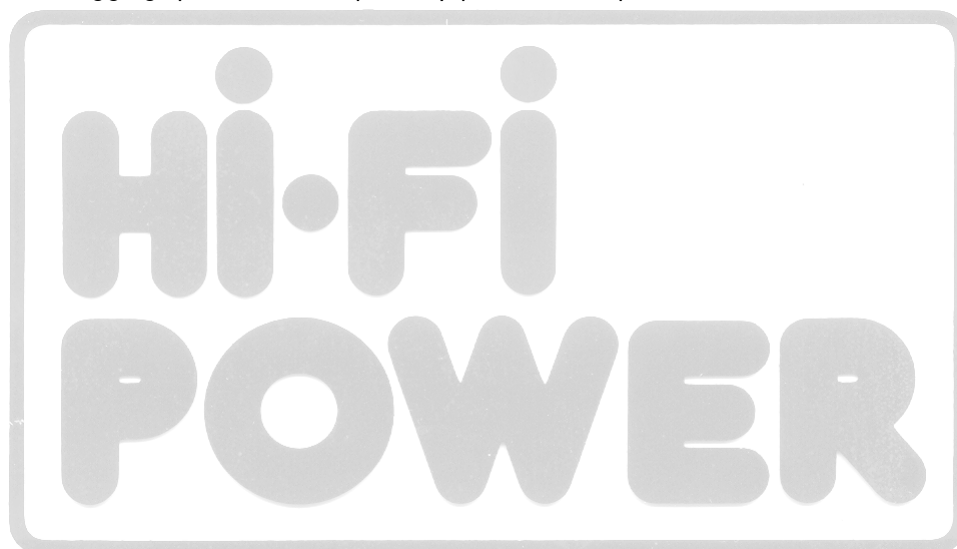

Loudspeaker configurations

SB18 Ili in standard configuration

Deployed in a standard configuration, an SB18 Ili system operates with an omnidirectional directivity pattern over the nominal bandwidth of the SB18 Ili enclosure.

The [SB18_60] and [SB18_100] factory presets provide the subwoofer system with an upper frequency limit at 60 Hz and 100 Hz respectively in order to optimize the acoustic coupling with a main full-range system.

The SB18 Ili subwoofer is driven by the LA2Xi / LA4X / LA8 / LA12X amplified controllers.



Reduced maximum SPL or drive capacity with LA2Xi: refer to the **LA2Xi owner's manual**.

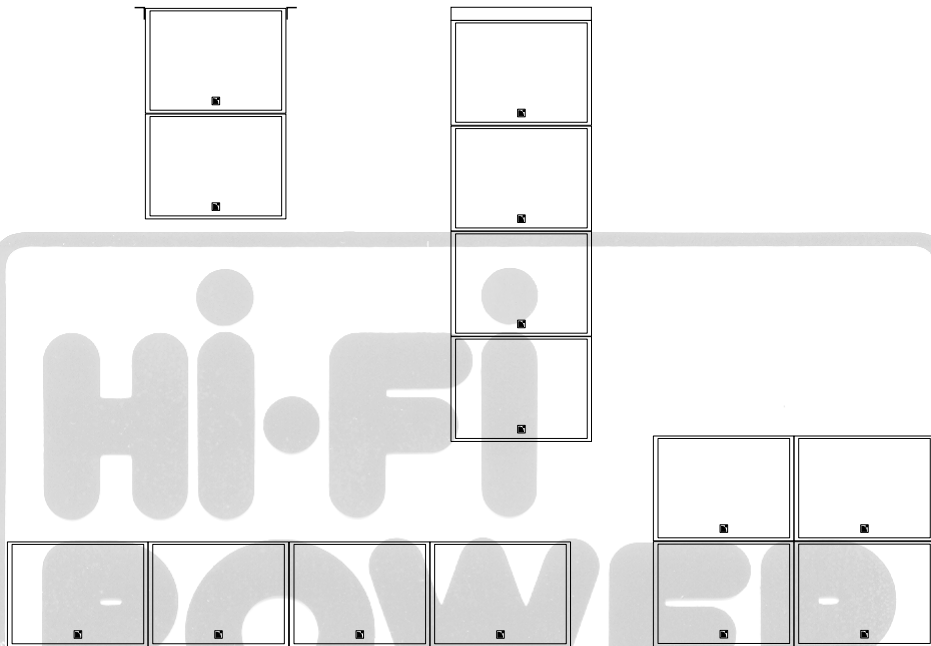

Preset	[SB18_60]	[SB18_100]
Low frequency limit (-10 dB)	32 Hz	



Delay values

When combining a line source with subwoofers, delays may have to be added to the presets.

Refer to the Preset Guide to obtain the pre-alignment delay values.

SB18 Ili in cardioid configuration

Deployed in a cardioid configuration, an SB18 Ili system produces a rear SPL rejection. The deployment consists of an array of four SB18 Ili with one element turned towards the rear (reversed). Refer to the **Cardioid Configuration** technical bulletin for more information.

The [SB18_60_C] / [SB18_60_Cx], and [SB18_100_C] / [SB18_100_Cx] factory presets provide the subwoofer system with an upper frequency limit at 60 Hz and 100 Hz respectively in order to optimize the acoustic coupling with a main full-range system.

The SB18 Ili subwoofer is driven by the LA2Xi / LA4X / LA8 / LA12X amplified controllers



Reduced maximum SPL or drive capacity with LA2Xi: refer to the **LA2Xi owner's manual**.



Preset	[SB18_60_C] / [SB18_60_Cx]	[SB18_100_C] / [SB18_100_Cx]
Low frequency limit (-10 dB)	32 Hz	



Delay values

When combining a line source with subwoofers, delays may have to be added to the presets. Refer to the Preset Guide to obtain the pre-alignment delay values.

Inspection and preventive maintenance

How to do preventive maintenance

Inspect the system after any corrective maintenance operation.

Perform preventive maintenance at least once a year.

Rigging and hardware

Perform the [Rigging part inspection](#) (p.27) on each rigging part.

Use the [Mechanical system overview](#) (p.27) to identify critical parts of the system.

If any parts are damaged, contact your L-Acoustics representative for further instructions.

Acoustics

Perform the [Enclosure check](#) (p.30).

Perform the [Listening test](#) (p.32) to detect any degradation in sound quality.

If necessary, refer to the [Corrective maintenance](#) (p.61) section for speaker repair kits and maintenance instructions.

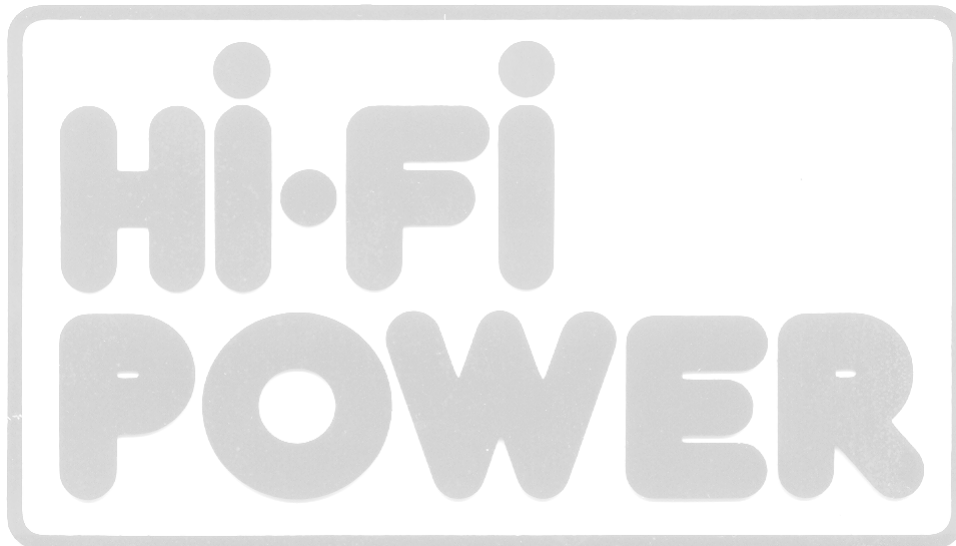

Rigging part inspection

About this task

The term "rigging part" comprises:

- lifting accessories such as clamps and shackles
- rigging accessories such as rigging frames, rigging interfaces, and brackets
- fasteners used for assembling two products together such as ball-locking pins, rigging axes, and safety pins
- rigging plates mounted on enclosures and their rigging screws
- screens mounted on enclosures

This inspection procedure covers only L-Acoustics products. To inspect other products that are part of the lifting chain, refer to the manufacturer's instructions.

Prerequisite

Perform the inspection in a well-lit environment.

Procedure

1. Check that the rigging part is present.

2. Check for:

- corrosion
- wear and cracks
- bends and dents
- holes
- missing safety cues
- missing identification labels
- missing or loose fasteners



Replacing screws

If a screw is loose, remove and replace it.

Always use the new screws provided in the repair kit.

If no new screw is available, add blue threadlocker before reusing the screw.

Do not apply more than the indicated torque.

3. Check the geometry of the part to identify critical deformations.

What to do next

If a problem is detected, perform the authorized maintenance operations or contact your L-Acoustics representative.

Mechanical system overview

Critical parts of the lifting chains are highlighted.



The  indicates a visual inspection.



Perform the [Rigging part inspection](#) (p.27) on critical parts.



Replacing screws

If a screw is loose, remove and replace it.

Always use the new screws provided in the repair kit.

If no new screw is available, add blue threadlocker before reusing the screw.

Do not apply more than the indicated torque.

Kara Ili and SB18 Ili array with KARAlli-BUMP and M-BARI

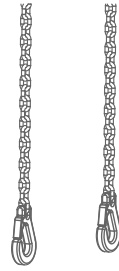

shackle axis end is flush with the shackle

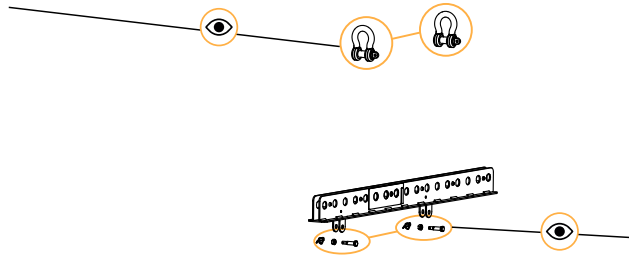
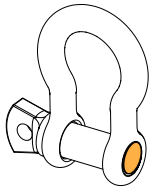

rigging axes are secured with nuts and safety pins

nuts are secured and tightened



Rigging part inspection (p.27)

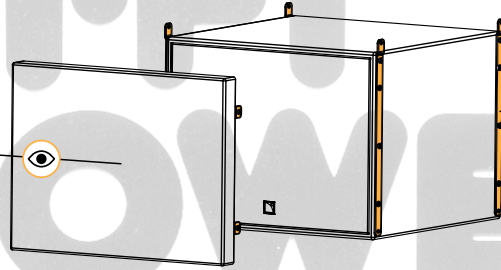

rigging screws are tightened
Rigging part inspection (p.27)

Rigging part inspection (p.27)

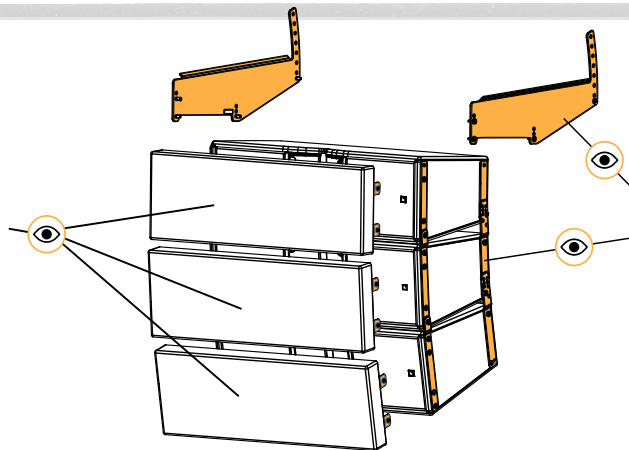

the plates are not bent
rigging screws are tightened
Rigging part inspection (p.27)

Kara Ili stacked on SB18 Ili

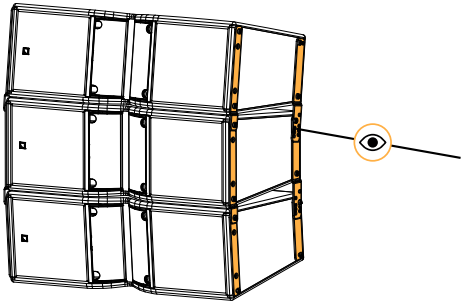

rigging screws are tightened
[Rigging part inspection](#)
(p.27)

the plates are not bent
[Rigging part inspection](#)
(p.27)

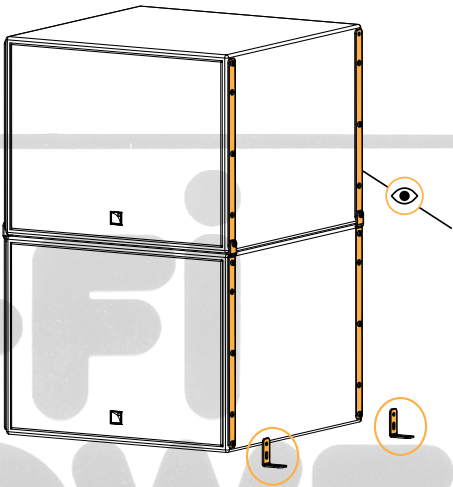

rigging screws are tightened
[Rigging part inspection](#)
(p.27)

the fixing brackets are present and tightened to the ground

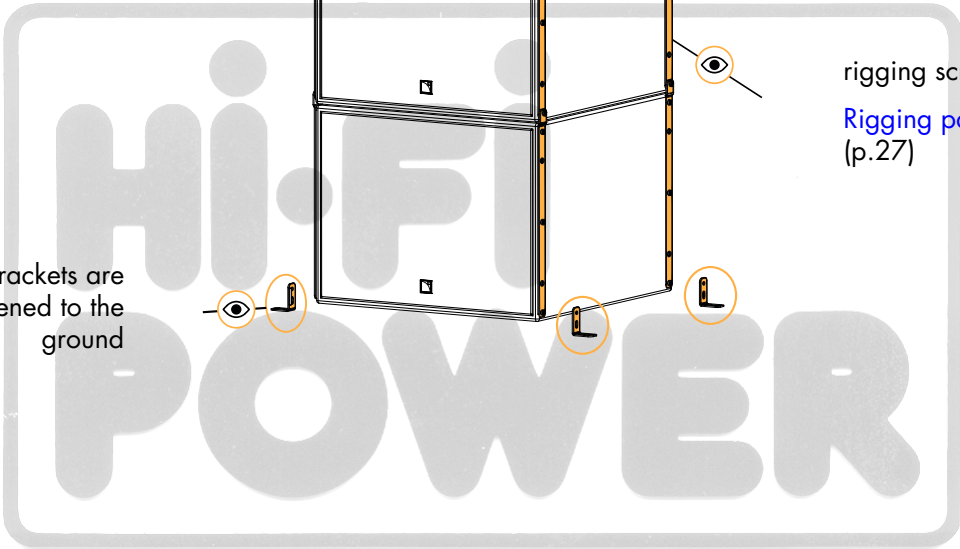

Acoustical check

Enclosure check



This feature is available on:

LA4X
LA12X

ENCLOSURE CHECK measures impedance at the reference frequencies for the connected loudspeaker family. The measured impedance is compared to the expected range allowing for fast detection of loudspeakers presenting circuit continuity issues.



The results can be used for preliminary diagnosis but cannot replace a comprehensive quality control.

Prerequisite



ENCLOSURE CHECK measurements can only be reliable if the following requirements are met:

Environment and temperature:

- Ambient temperature must be comprised between 0 °C / 32 °F and 40 °C / 104 °F. Ideal temperature is 20 °C / 68 °F.
- Enclosures must be at room temperature. If warm from a recent high level use or recently moved from a cold environment, let the loudspeakers reach room temperature before starting.

Enclosures:

- Enclosures must be included in the embedded factory preset library.
- Enclosures must be in nominal operating conditions:
 - Remove covers or dollies obstructing the loudspeakers or the vents.
 - Check for obvious physical damage or air leak: visually inspect the grill, gasket, cabinet, and connector plate for loose, missing or damaged parts.

Connection:

- Use only 10 m / 30 ft 4 mm² / AWG 11 speaker cables.
- Do not connect enclosures in parallel.

Amplified controllers:

- LA4X must run at least firmware version 1.1.0.
- LA4X load sensors must be calibrated. Refer to the **Load Sensor Calibration Tool** technical bulletin for more information.
- LA4X must warm up for at least 10 minutes after power up. Do not power off, reboot or switch to standby mode to avoid resetting the countdown.
- Load a preset corresponding to the connected loudspeaker's family. Presets from the user memories may be used on condition they are made of presets supported in the embedded factory preset library.

Procedure

1. Power up the amplified controller. Let LA4X warm up for at least 10 minutes.
2. Connect the loudspeaker enclosures to the amplified controller.
3. Load a preset from or built from the embedded library corresponding to the connected loudspeaker family.
4. On the amplified controller, use the encoder wheel to select **MONITORING & INFO**. Press the OK key or the encoder wheel to validate.
5. Use the encoder wheel to select **ENCLOSURE CHECK**.



Beware of sound levels.

Although the sound pressure levels generated for the ENCLOSURE CHECK are moderate, do not stay within close proximity of the loudspeakers and consider wearing ear protection.

6. Press the OK key or the encoder wheel to launch the ENCLOSURE CHECK.

The amplified controller generates short sinusoidal signals simultaneously for each connected output.

The amplified controller displays the results for each output.

7. Depending on the displayed results, follow the instructions in the table.

result	interpretation	instructions
OK	measured impedance is within expected range	enclosure is in working order electrically
?	unsupported preset family	only supported enclosures should be tested
NC	Not Connected	if cables are connected: a. inspect the cables and connections b. go to step 8 (p.31)
NOK	measured impedance is not within expected range	a. check that all the prerequisites are met, in particular that the loaded preset corresponds to the connected speaker's family b. inspect the cables and connections c. go to step 8 (p.31)
UNDEF	measured impedance is undefined	

8. Under NC, NOK and UNDEF results, press and hold the corresponding OUT key.

The amplified controller displays:

- the tested frequencies,
- information on the measured impedance:
 - OPEN for open circuit (found in NC results),
 - SHORT for short circuit (found in NOK results), or
 - a percentage of variation from the expected range (found in NOK and UNDEF results)
- the number of operational transducers out of the total



Low variations from the expected range are acceptable: displayed percentage can be different from 0 and all transducers considered operational.

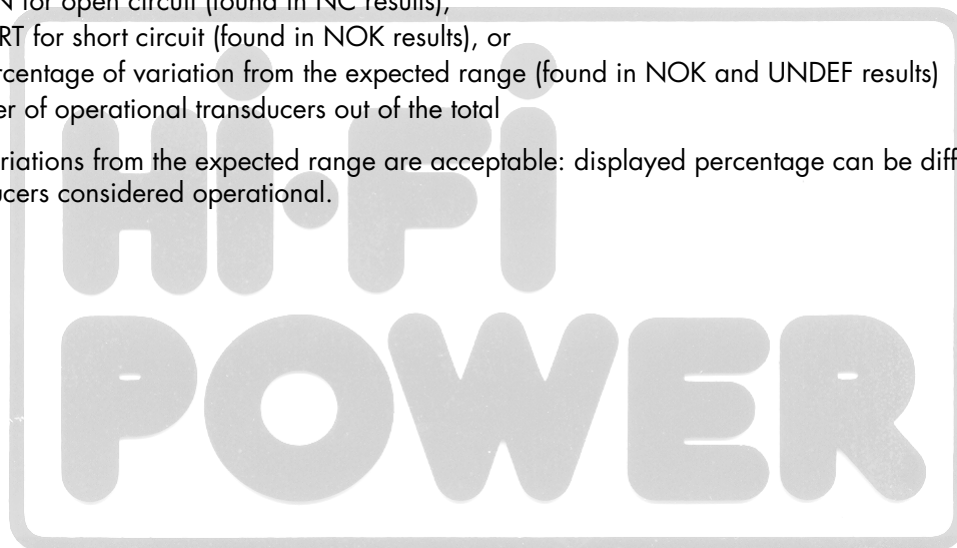

Listening test

enclosure	preset	usable bandwidth
SB18 Ili	[SB18_100]	32 Hz - 110 Hz

Procedure

1. Load the preset on an LA2Xi / LA4X / LA8 / LA12X amplified controller.
2. Connect a sinus generator to the amplified controller.



Risk of hearing damage

Set a low sound level to start and use ear protection to adjust before testing.

3. Scan the bandwidth focusing on the usable range.
The sound should remain pure and free of unwanted noise.

Troubleshooting for LF speakers

One or more LF speaker produces distorted, buzzing, rubbing, clicking, muffled or weak sound.

Possible causes

- The screws are not tightened with the appropriate torque.
- There is an air leak in the gasket.
- There is dust on the cone.
- The cone is damaged.
- The surround is torn or delaminated.
- The voice coil or the spider is damaged.

Procedure

1. Perform the speaker disassembly procedure.
2. Visually inspect the cables and the connectors.
3. Visually inspect the speaker cone, the voice coil and the spider.

If any damage is visible, replace the speaker.

4. Carefully clean the speaker with a dry cloth.
5. Perform the reassembly procedure.
Replace the speaker gasket and the screws.
Apply the recommended torque.

6. Repeat the listening test.

If the problem persists, replace the speaker.

Rigging procedures

General principles

This introduction provides general principles applicable for all configurations.

Safety



Rigging screws

Only use the rigging screws provided by L-Acoustics.
Do not use the placeholder screws for rigging.

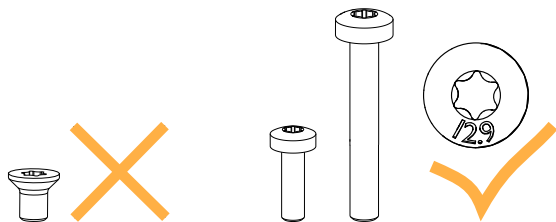

Tightening screws

Do not fully tighten the screws unless instructed to do so.

After securing an enclosure to another enclosure, tighten all the screws on the supporting enclosure. Apply a torque of 5 N.m.

Stacking enclosures

When stacking two enclosures, the top enclosure must be slightly lifted to align the inserts with the rigging plate holes. Use an accessory like a wedge or a lever to adjust the height of the enclosure. Be careful not to scratch the paint.

HI-FI
POWER

Flying

Flying an array with KARAIi-BUMP

Type of deployment	flown array
Rigging accessories	KARAIi-BUMP M-BARi (optional) SB18 Ili rigging plates
Screws and fasteners	M6×18 Torx rigging screws (provided) M6 hex lock nuts (provided)
Tools	torque screwdriver T30 Torx bit 10 mm wrench or 10 mm hex socket 13 mm hex socket and 13 mm wrench (for M-BARi)
Min. number of operators	3

Rigging plates



SB18Ili-LINK

Rigging plates for SB18 Ili



Risk of falling objects

Verify that no unattached items remain on the product or assembly.



Secondary safety

Use available holes on the rigging accessories to implement a secondary safety.

Assembly

Procedure

1. Prepare all SB18 Ili needed for the array.
 - a) Remove the placeholder screws.

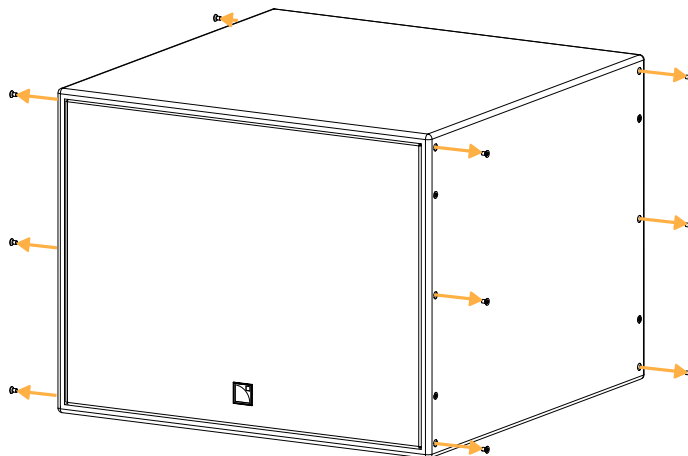

- b) Secure SB18Ili-LINK on the enclosures.
Do not secure the bottom screws, except on the last enclosure of the array.

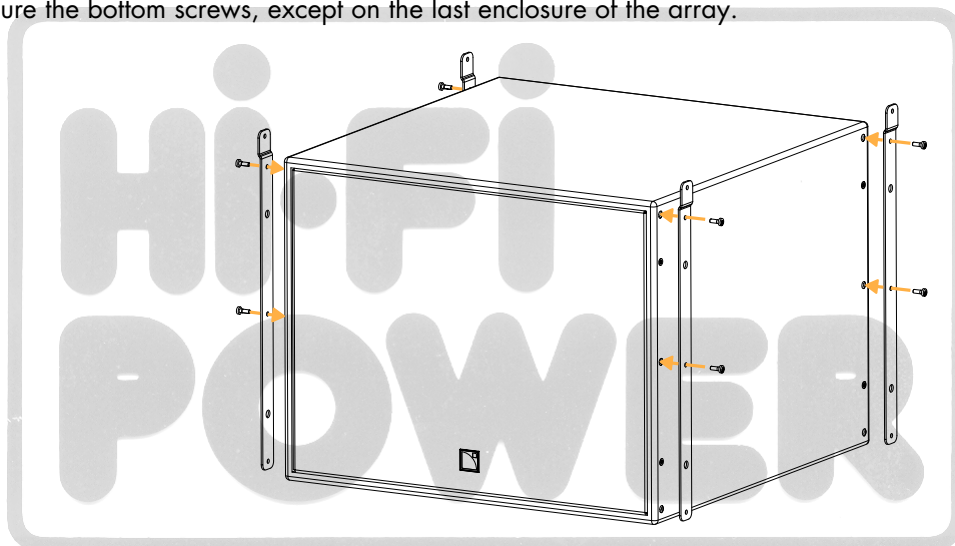

2. Secure KARAlli-BUMP on top of a first SB18 Ili.

i Optionally, secure M-BARi on KARAlli-BUMP to extend the site angle capability. Use the provided rigging axes, nuts, and safety pins.

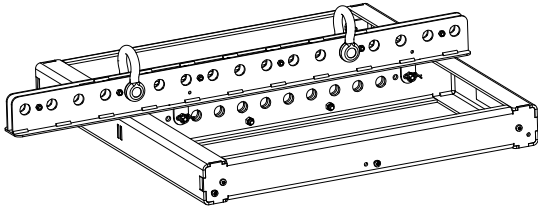

Tighten all the screws on KARAlli-BUMP. Apply a torque of 5 N.m.

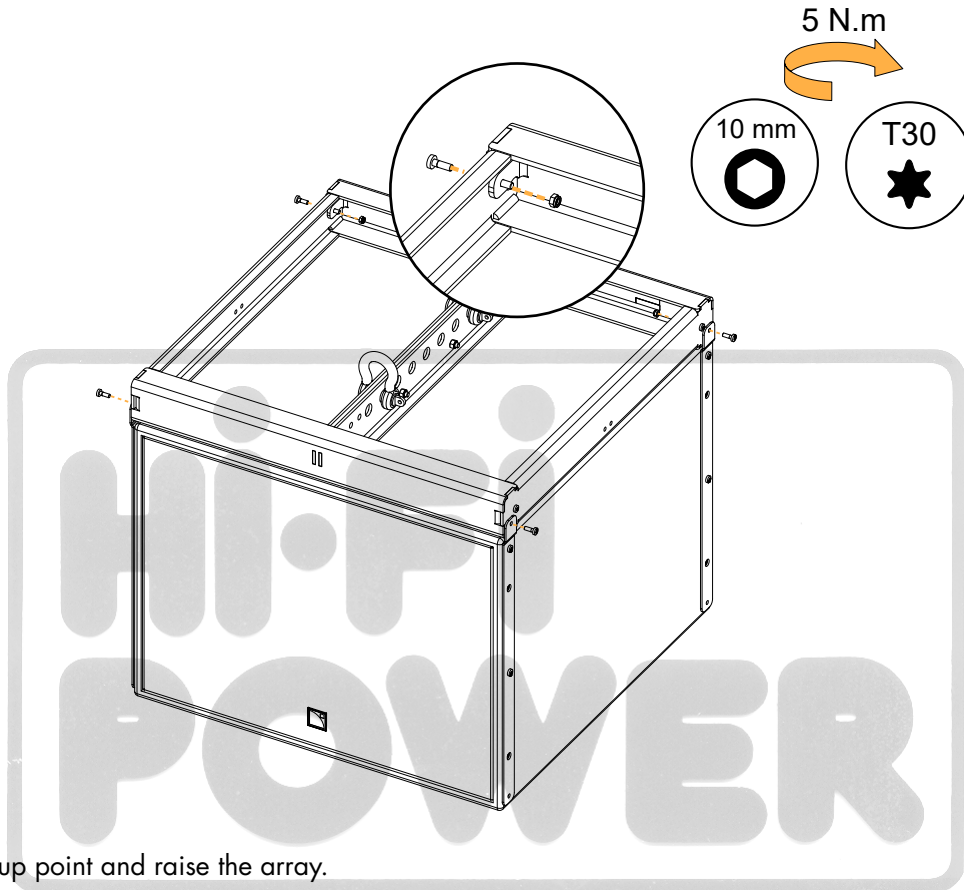

3. Select the pickup point and raise the array.

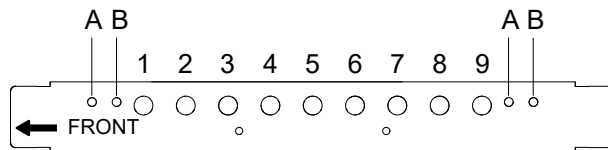

KARAlli-BUMP pickup points

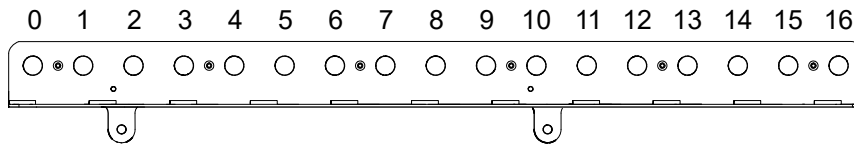

M-BARi pickup points

4. Secure a second SB18 Ili under the array.

a) Place SB18 Ili (equipped with SB18Ili-LINK) under the array.

b) Lower the array until the enclosures can be assembled.

The rigging plates of the bottom enclosure overlap the rigging plates of the top enclosure.

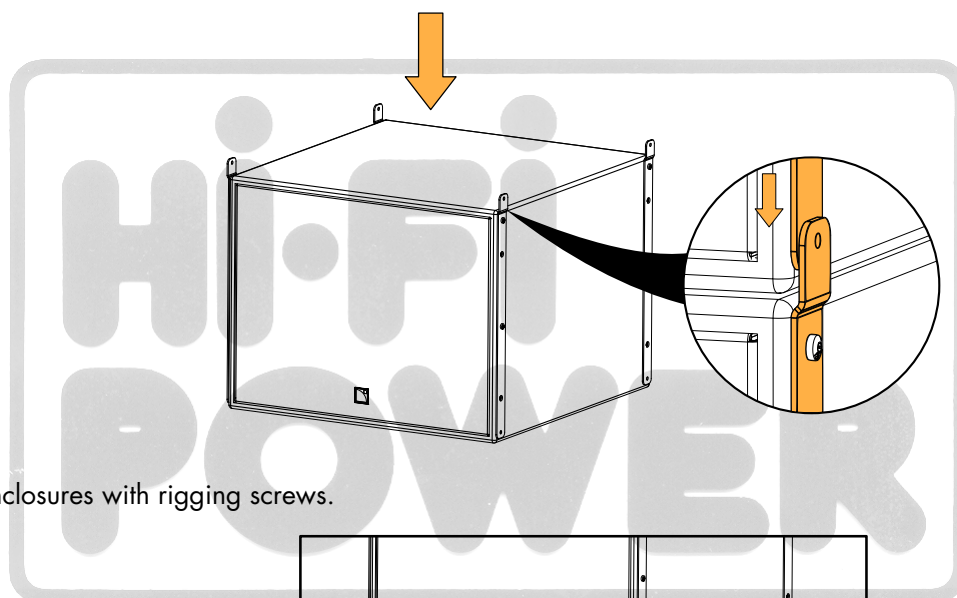
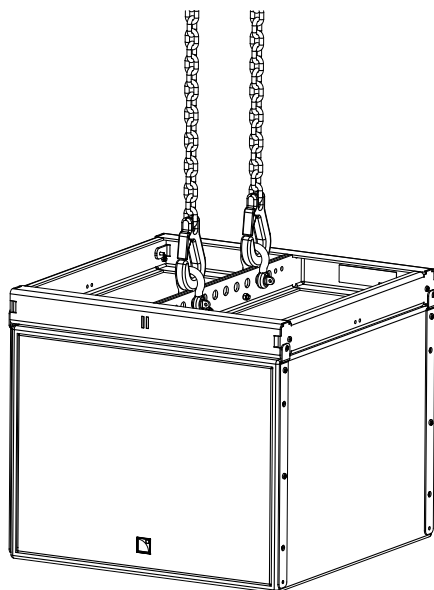

c) Link the enclosures with rigging screws.

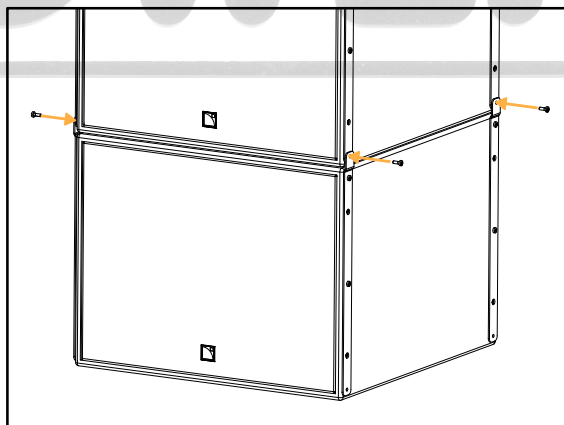

d) Tighten all the screws on the supporting enclosure.

Apply a torque of 5 N.m.

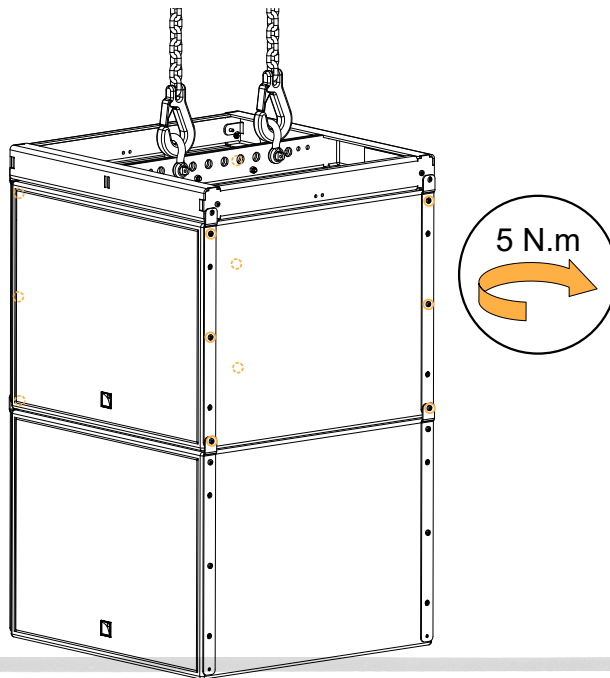

e) Raise the array.

5. Repeat step 4 (p.36) until all SB18 Ili are assembled.

6. Check that all screws are present and tightened, and raise the array.

What to do next

- [Adding a pullback with KARAlli-RIGBAR](#) (p.41)
- [Securing a screen](#) (p.52)

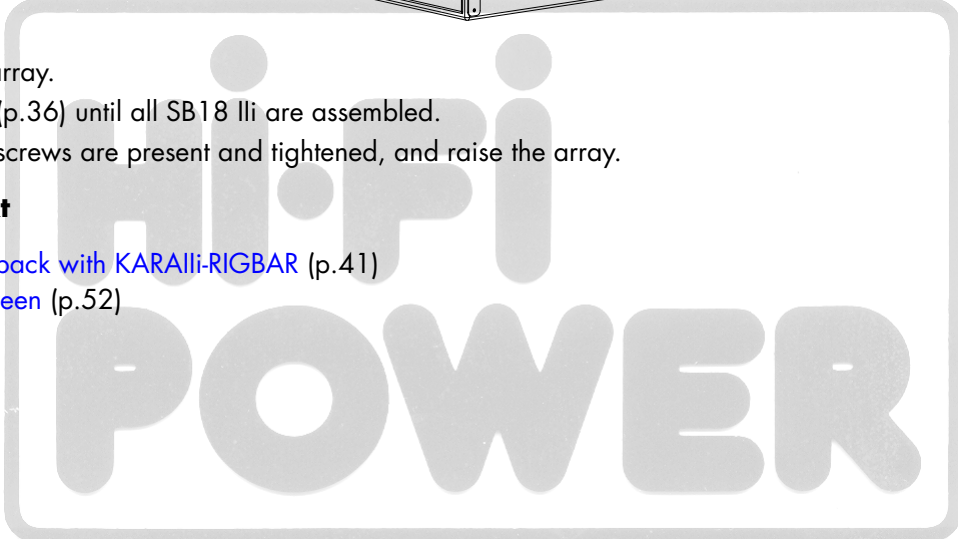

Flying an array with KARAlli-RIGBAR

Type of deployment	flown
Rigging accessories	KARAlli-RIGBAR SB18 Ili rigging plates
Screws and fasteners	M6x40 Torx rigging screws (provided) M6x18 Torx rigging screws (provided)
Tools	torque screwdriver T30 Torx bit
Min. number of operators	3

Rigging plates

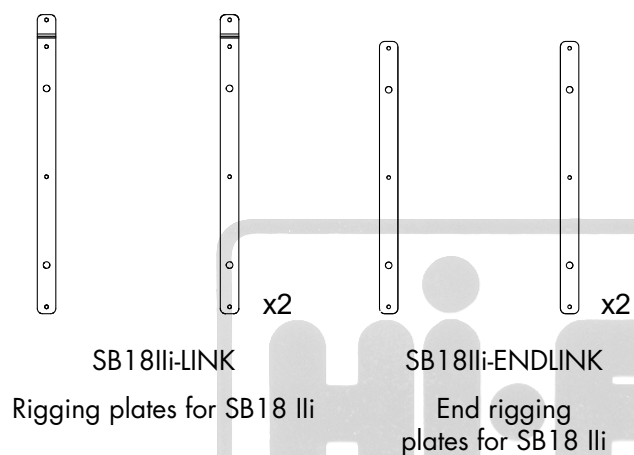

- ⚠ Risk of falling objects**
Verify that no unattached items remain on the product or assembly.
- ⚠ Secondary safety**
Use available holes on the rigging accessories to implement a secondary safety.

Assembly

Procedure

1. Prepare the first enclosure.
 - a) Remove the relevant placeholder screws.

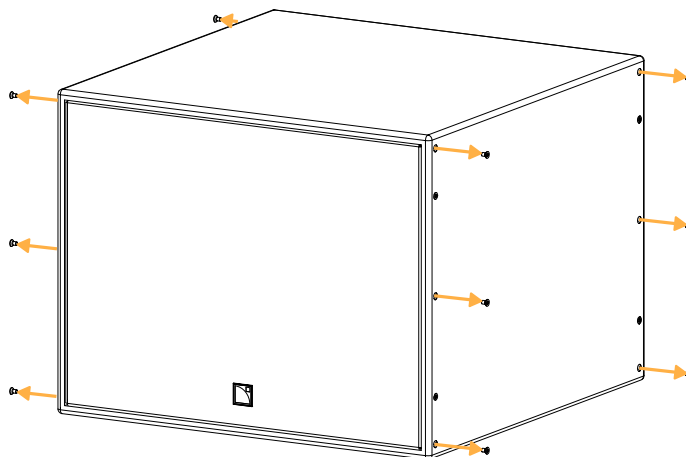

- b) Secure SB18Ili-ENDLINK on the enclosure.
Do not secure the rear top screws on each side.

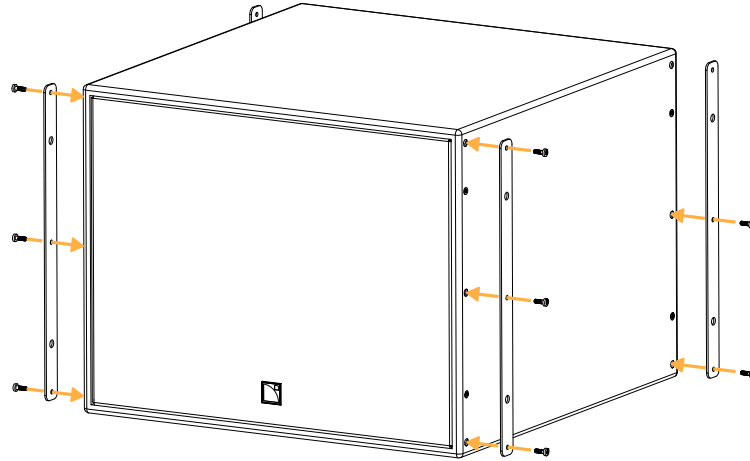

2. Secure KARAlli-RIGBAR at the rear of the enclosure with M6x40 Torx rigging screws.



Secure KARAlli-RIGBAR at the front for a positive initial site angle.

Tighten the screws with a 5 N.m. torque.

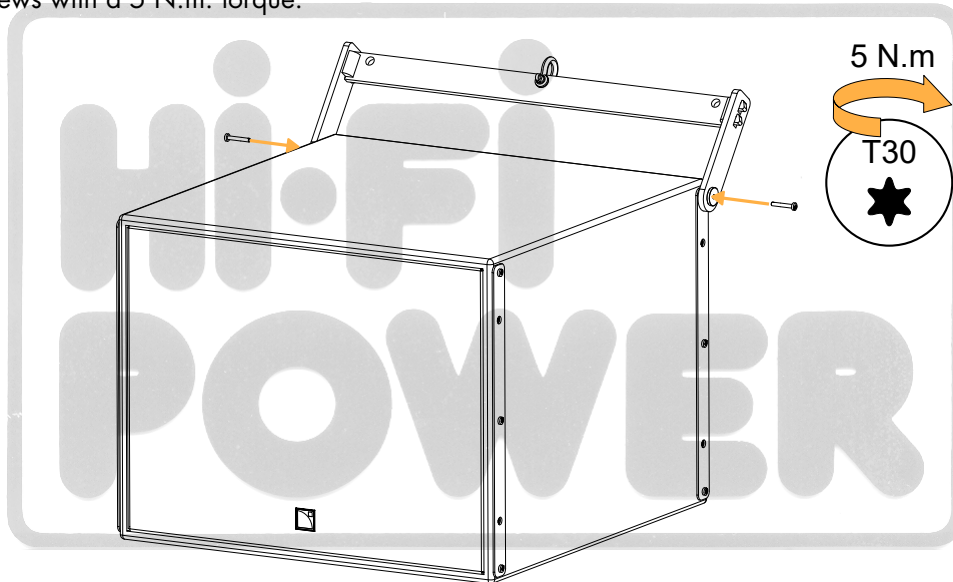

3. Secure a shackle or CLAMP250 to KARAlli-RIGBAR and raise the array.



Maximum limit with CLAMP250.

CLAMP250 has a WLL (Working Load Limit) of 250 kg / 550 lb. It can support an array of up to 5 SB18 Ili. For an hybrid array, check the total weight of the array in Soundvision.

For more information, refer to the **CLAMP250 owner's manual**.

4. To complete the array, follow the procedure in [Flying an array with KARAlli-BUMP](#) (p.34).

What to do next

- [Adding a pullback with KARAlli-RIGBAR](#) (p.41)
- [Securing a screen](#) (p.52)

Adding a pullback with KARAlli-RIGBAR

Type of deployment	flown with pullback
Rigging accessories	KARAlli-RIGBAR
Screws and fasteners	M6x40 Torx screws (provided)
Tools	torque screwdriver T30 Torx bit
Min. number of operators	1

Assembly

Prerequisite

Prepare the array as described in [Flying an array with KARAlli-RIGBAR](#) (p.39).

Procedure

1. Raise the array until the bottom enclosure is accessible.
2. Remove the bottom screw from the rear rigging plates on each side.

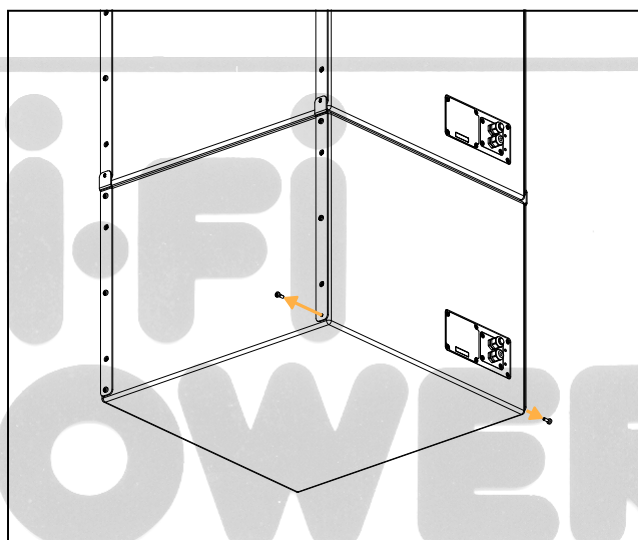

3. Secure KARAlli-RIGBAR at the rear of the enclosure with M6x40 Torx screws.

Apply a torque of 5 N.m.

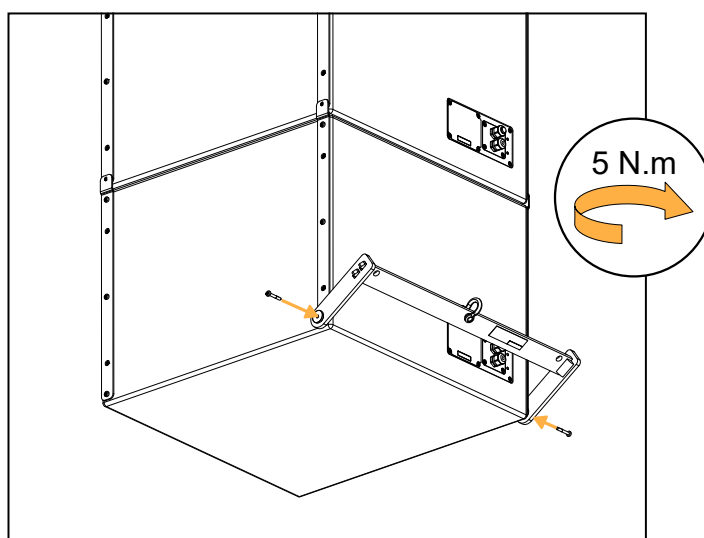

4. Secure a shackle to KARAlli-RIGBAR and lift it with an additional motor.

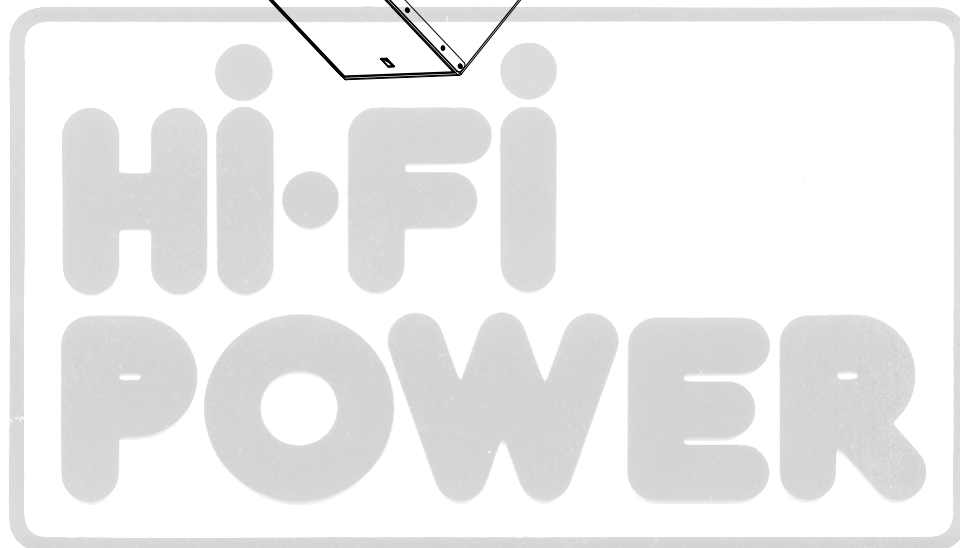
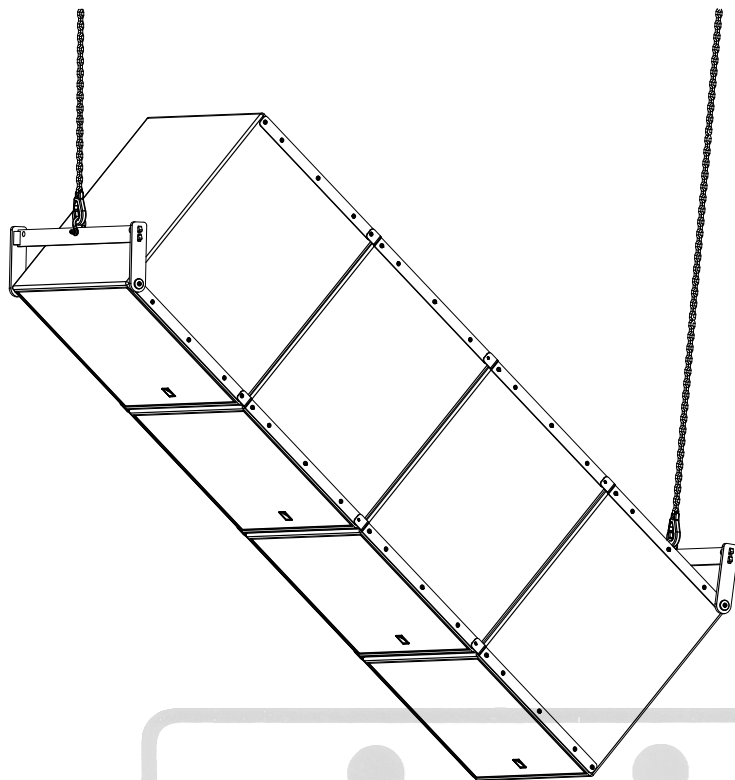

Ceiling-mounting

Mounting an array with KARAIi-FIXBRACKET

Type of deployment	ceiling-mounted
Rigging accessories	KARAIi-FIXBRACKET SB18Ii-ENDLINK
Screws and fasteners	M6×18 Torx rigging screws (provided) 4 × M10 screws and anchors
Tools	torque screwdriver T30 Torx bit
Min. number of operators	3

Rigging plates

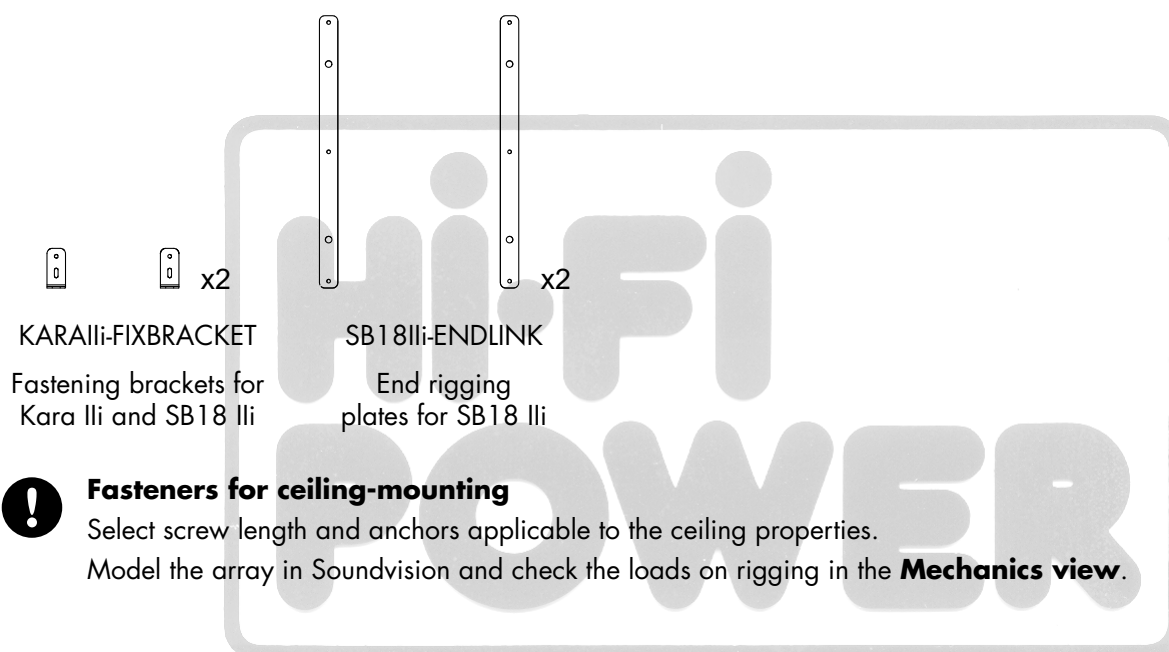

Fasteners for ceiling-mounting

Select screw length and anchors applicable to the ceiling properties.

Model the array in Soundvision and check the loads on rigging in the **Mechanics view**.

Assembly

Procedure

1. Secure KARAlli-FIXBRACKET to the ceiling using M10 screws.



Fasteners for ceiling-mounting

Select screw length and anchors applicable to the ceiling properties.

Model the array in Soundvision and check the loads on rigging in the **Mechanics view**.

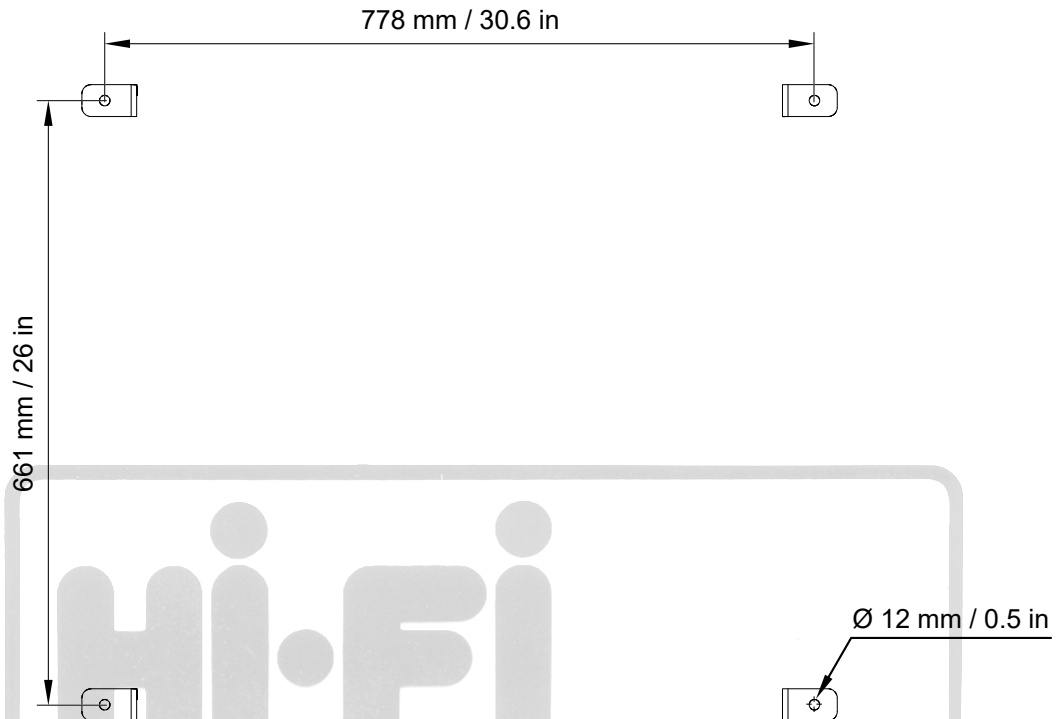

2. Prepare an SB18 Ili.

a) Remove the placeholder screws.

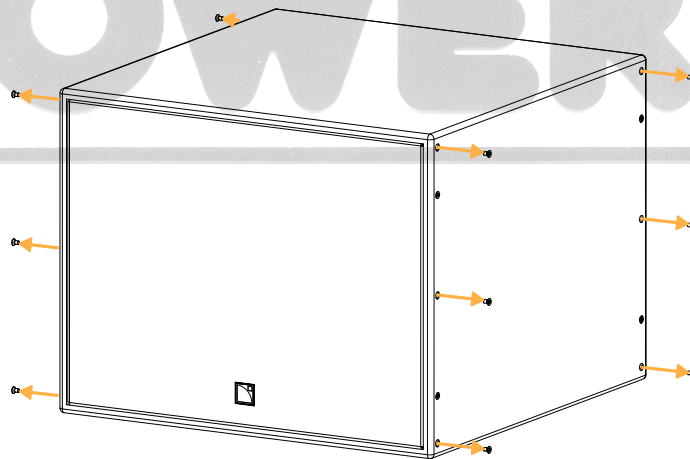

b) Secure SB18Ili-ENDLINK on the enclosure.

Do not secure the top screws.

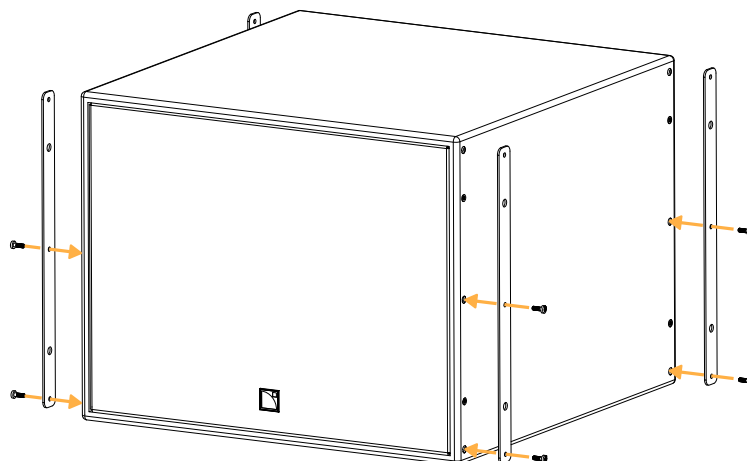

This step requires three operators.

Hold the enclosure at the bottom until the rigging plates are secured.

3. Lift SB18 Ili and secure it to the slotted holes on KARAlli-FIXBRACKET with rigging screws.

Apply a 5 N.m. torque.

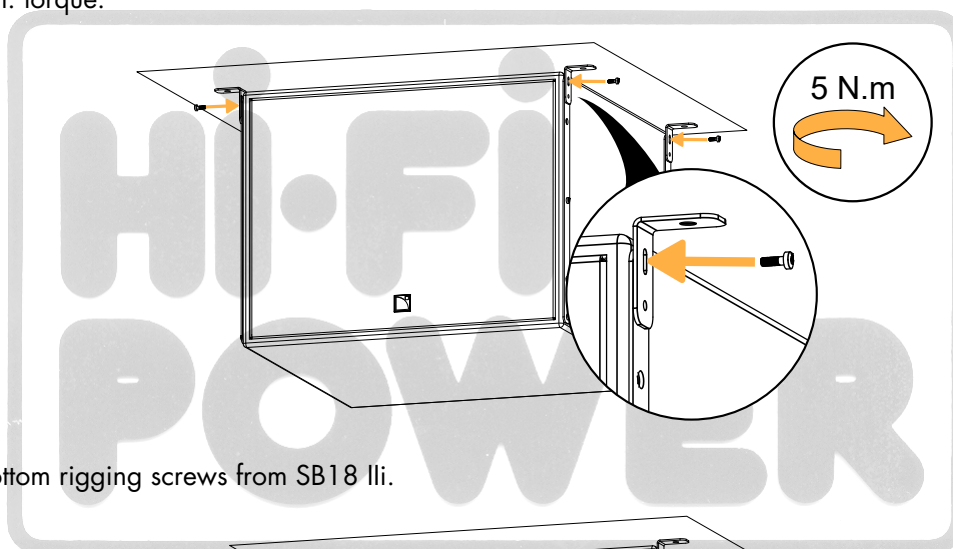

4. Remove the bottom rigging screws from SB18 Ili.

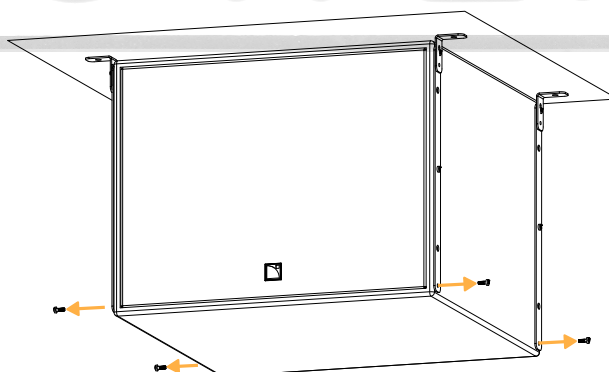

5. Prepare a second SB18 Ili.
 - a) Remove the placeholder screws.

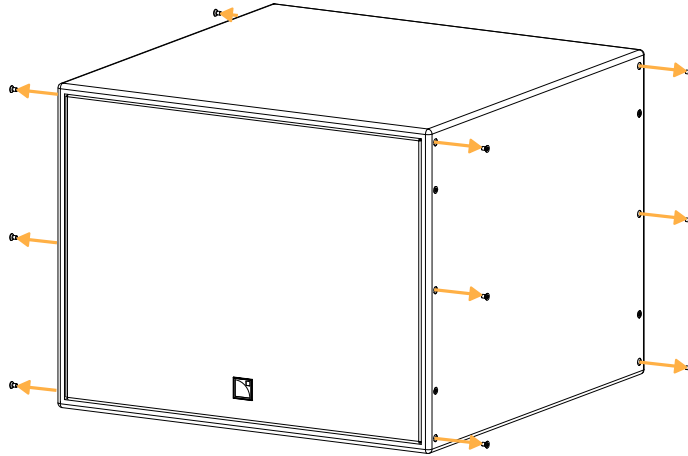

- b) Secure SB18Ili-LINK on the enclosure.

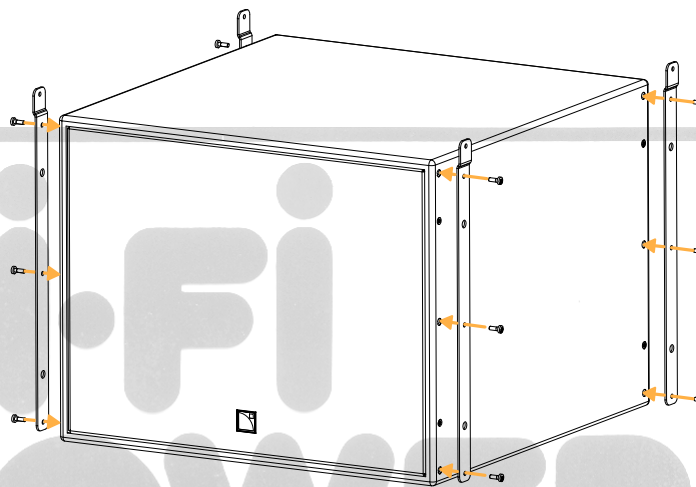

This step requires three operators.

Hold the enclosure at the bottom until the rigging plates are secured.

6. Lift SB18 Ili and secure it under the first one with rigging screws.

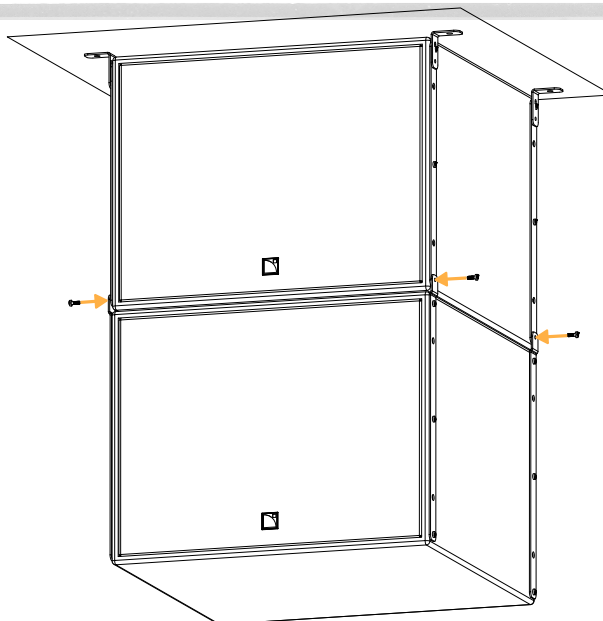

- 7.** Tighten all the screws.
Apply a 5 N.m. torque.

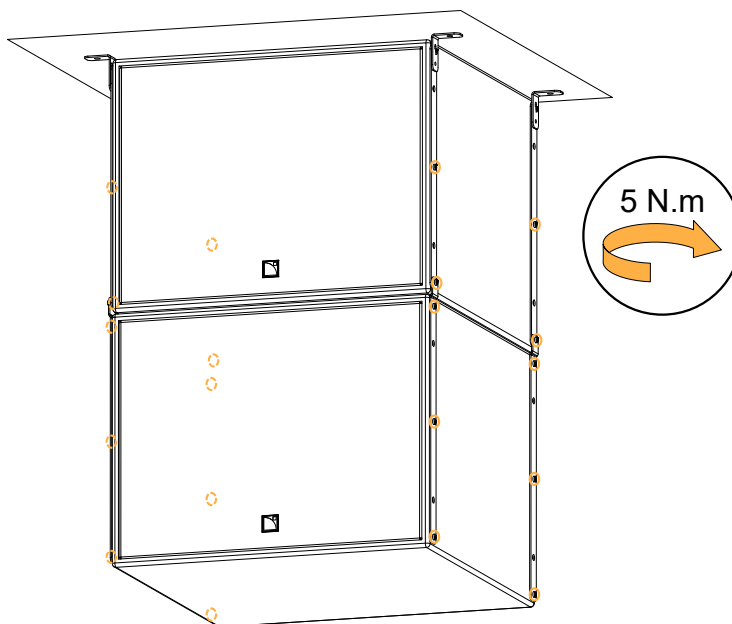

- 8.** Check that all screws are secured and tightened.

What to do next

- [Securing a screen](#) (p.52)

Hi-Fi
POWER

Stacking

Stacking an array with KARAIi-FIXBRACKET

Type of deployment	stacked
Rigging accessories	KARAIi-FIXBRACKET SB18IIi-ENDLINK
Screws and fasteners	M6×18 Torx rigging screws (provided) 4 × M10 screws and anchors
Tools	torque screwdriver T30 Torx bit
Min. number of operators	3

Rigging plates

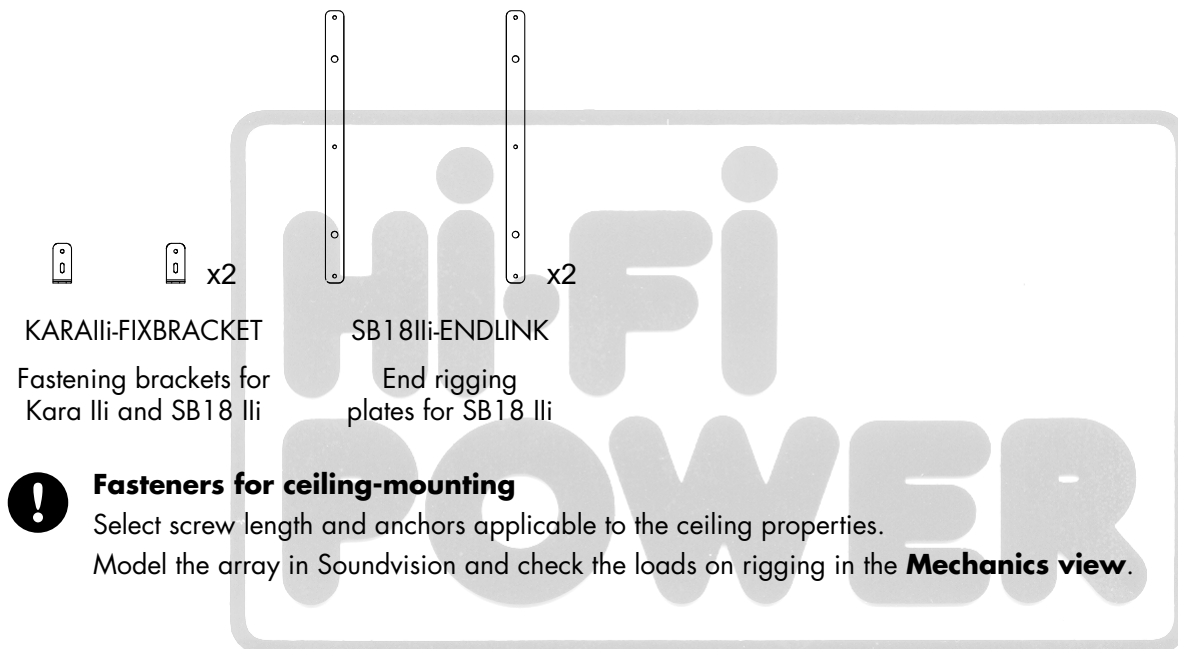

Assembly

Procedure

1. Secure KARAlli-FIXBRACKET to the ground using M10 screws.

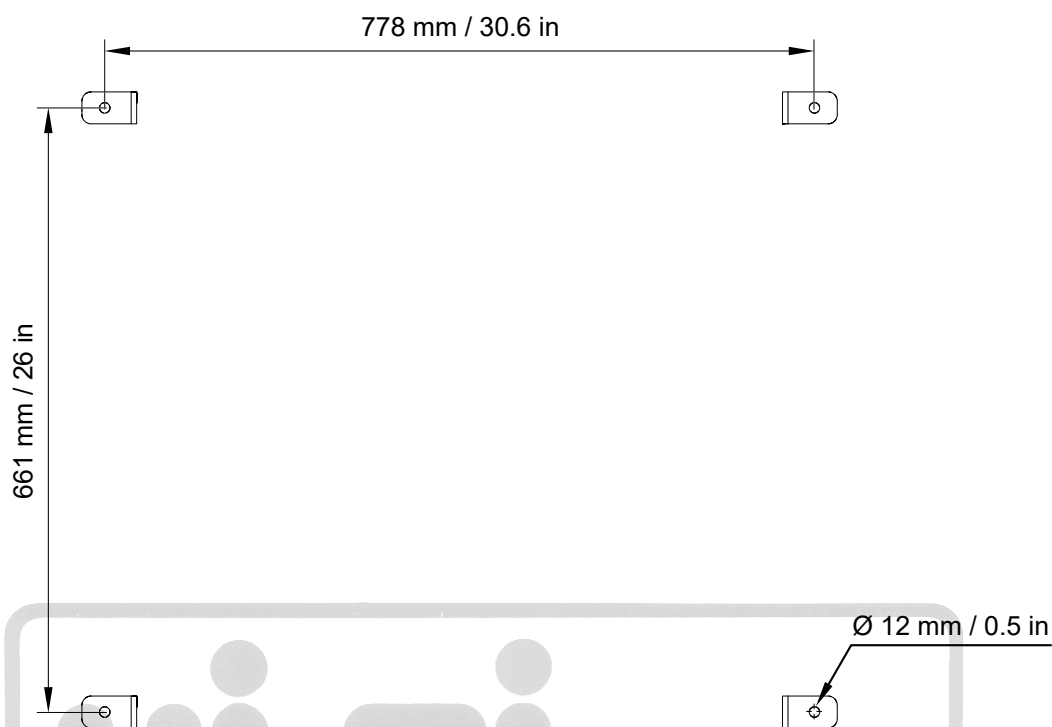

2. Prepare up to four SB18 Ili.
 - a) Remove the placeholder screws.

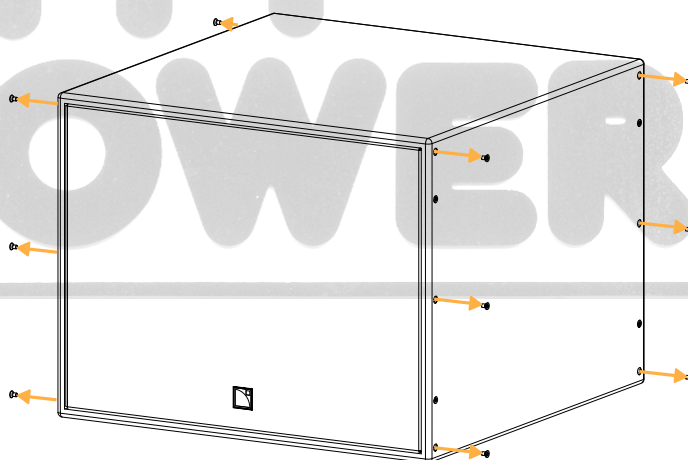

b) Secure SB18Ili-LINK on the enclosure.

Do not secure the bottom screws.

On the last enclosure of the array, secure SB18Ili-ENDLINK instead.

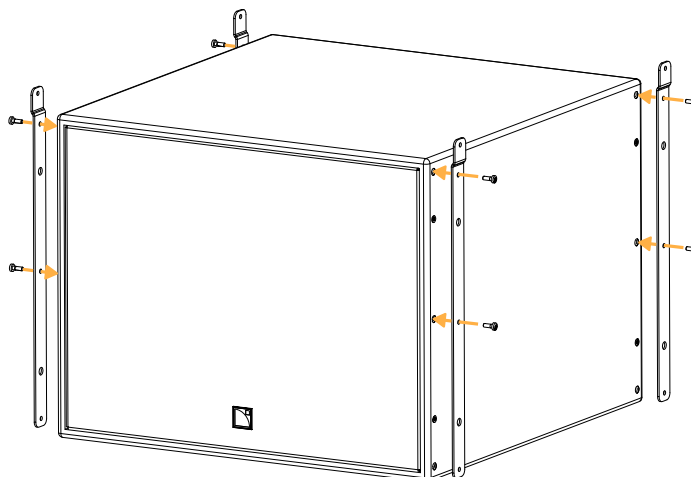

Risk of crushing injury

Keep fingers away from underneath the enclosure.

3. Secure SB18 Ili to the slotted holes on KARAIli-FIXBRACKET.

Tighten the bottom screws. Apply a 5 N.m. torque.

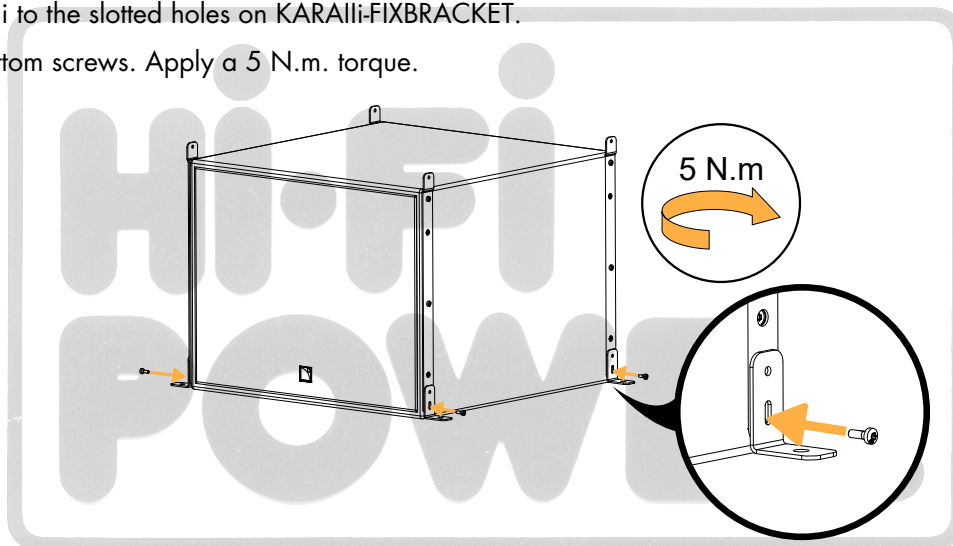



Risk of crushing injury

Keep fingers away from underneath the enclosure.

- Secure additional SB18 Ili (equipped with rigging plates) on top of the first one.



Adjusting the gap between stacked enclosures

Place a wedge or a lever between the two enclosures to align the rigging with the inserts.
Be careful not to scratch the paint.

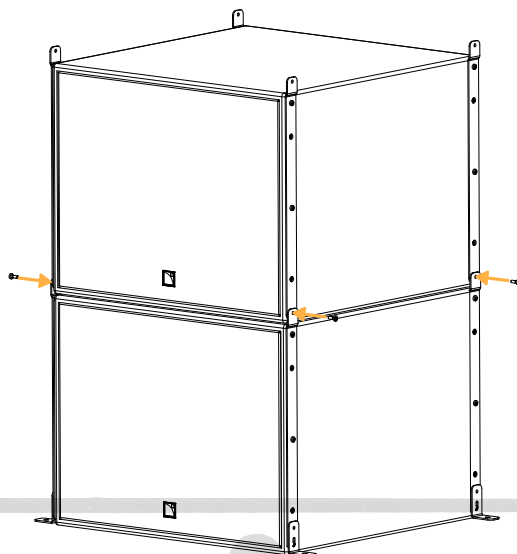

- Repeat step 4 (p.51) until the array is completed.
The last SB18 Ili must be equipped with SB18Ili-ENDLINK.
- Tighten all the screws on the array.
Apply a torque of 5 N.m.

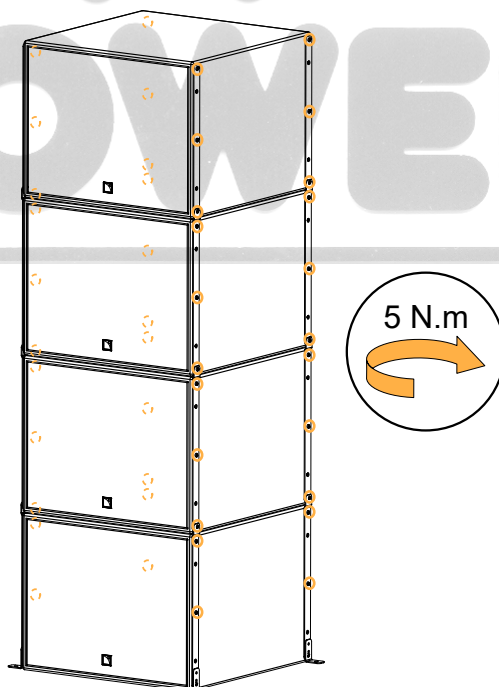

- Check that all screws are secured and tightened.

What to do next

- Securing a screen (p.52)

Securing a screen

Accessories	SB18Ili-SCREEN
Screws and fasteners	M6×35 Torx screws (provided) M6 self-sticking washers for configurations without rigging plates (provided)
Tools	torque screwdriver T30 Torx bit
Min. number of operators	1

Assembly

Prerequisite



Secure the screens on the enclosures after the array is fully assembled.

Procedure

1. Remove the grill screws.



Do not remove the enclosure grills.
Hold the grills in place until the screens are secured.

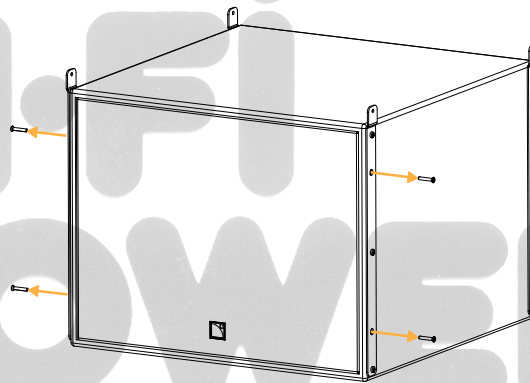

2. If the enclosure is not equipped with rigging plates (standalone, ground-stacked enclosure), stick the washers on the screen fixing tabs.



Risk of bending fixing tabs

Always use the self-sticking washers for securing screens when there are no rigging plates on the enclosure.

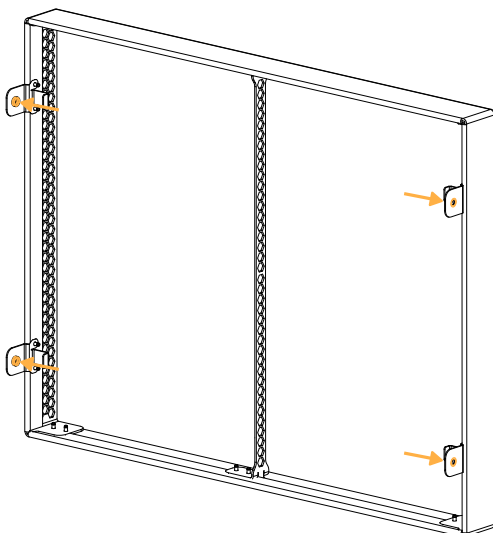



Risk of falling objects

Only use the provided M6x35 Torx screws to secure the screens.

- Secure the screen to the enclosure.

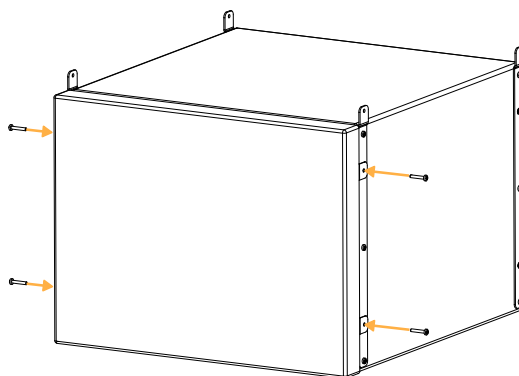

If SB18 Ili is reversed (cardioid configuration), connect the cables to the enclosure before securing SB18Ili-SCREEN.

Pass the cables through the cutout on the screen side.

See [Connection to LA amplified controllers](#) (p.54) for cabling instructions.

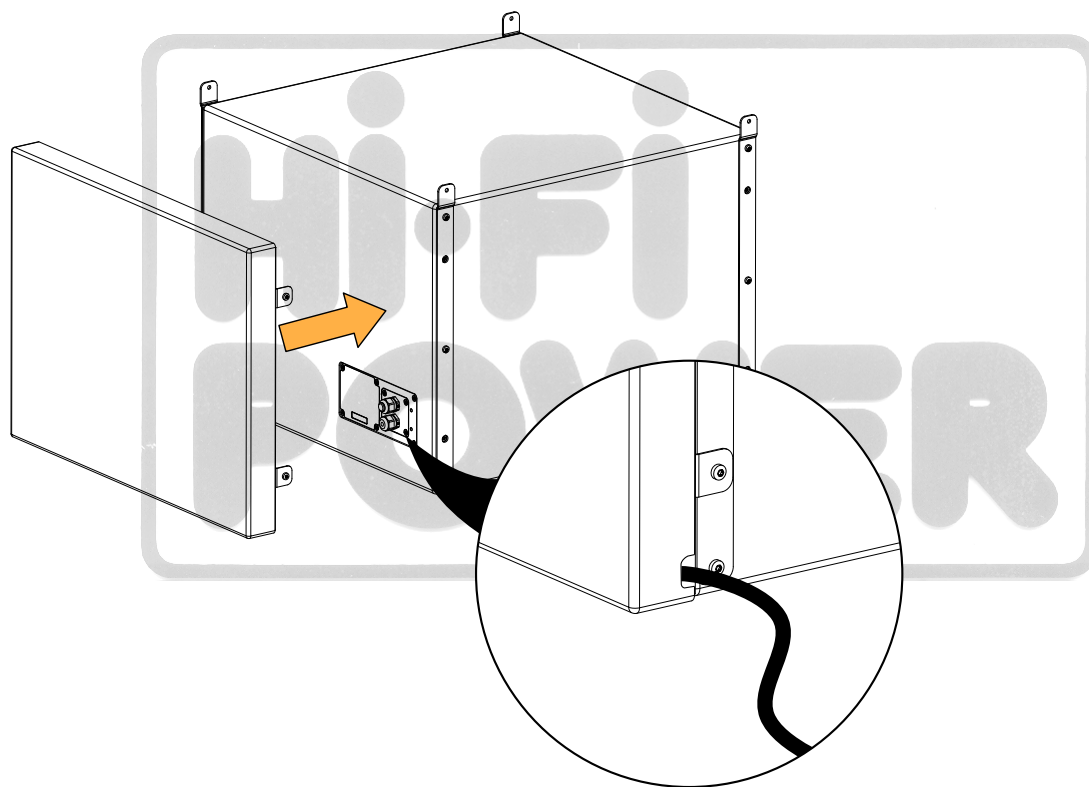

Connection to LA amplified controllers

! Refer to the **Amplification reference** technical bulletin for the latest information on compatibility with amplified controllers and cabling schemes for all enclosure types.

Enclosure drive capacity per amplified controller

Make sure the total number of connected enclosures does not exceed the maximum number of enclosures per controller (refer to the footnotes).

	LA2Xi	LA4X	LA8	LA12X
	per output * / total	per output * / total	per output * / total	per output * / total
SB18 Ili	1 / 4 (SE), 1 / 2 (BTL)	1 / 4	2 / 6**	3 / 12

i Reduced maximum SPL or drive capacity with LA2Xi: refer to the **LA2Xi owner's manual**.

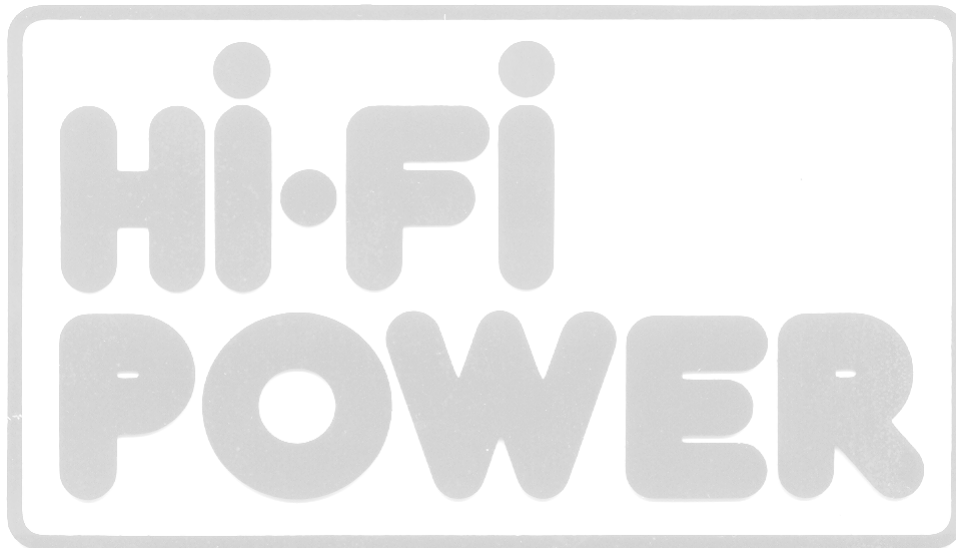

* For passive loudspeakers, the value corresponds to the number of enclosures in parallel on the output. For active loudspeakers, the value corresponds to the number of sections in parallel on the output.

** LA8 can drive up to two SB18 Ili per output, but no more than six per controller at high level.

Cabling schemes

! Refer to the cable manufacturer documentation for the wire color code.

Cabling schemes for SB18 Ili

Refer to the cabling schemes to connect the enclosures to different types of connectors and output configurations.

i Refer to the **LA2Xi owner's manual** for more information on output configurations.

Terminal block output (SE)

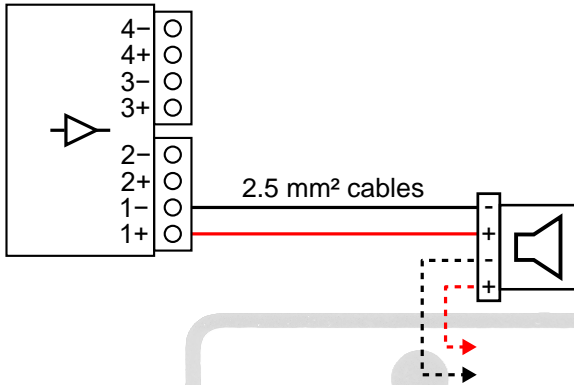

Terminal block output (BTL)

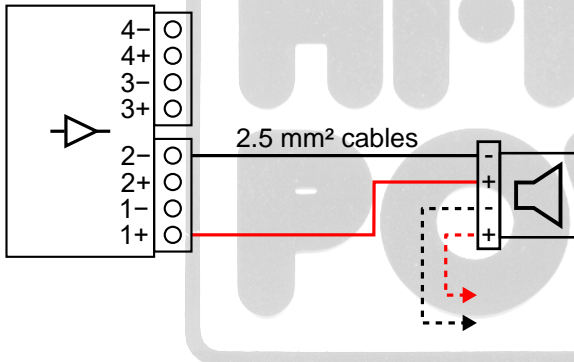

One-channel speakON output

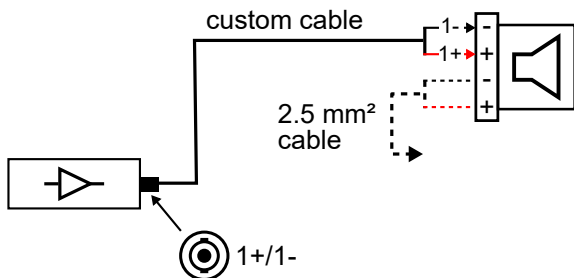

Two-channel speakON output

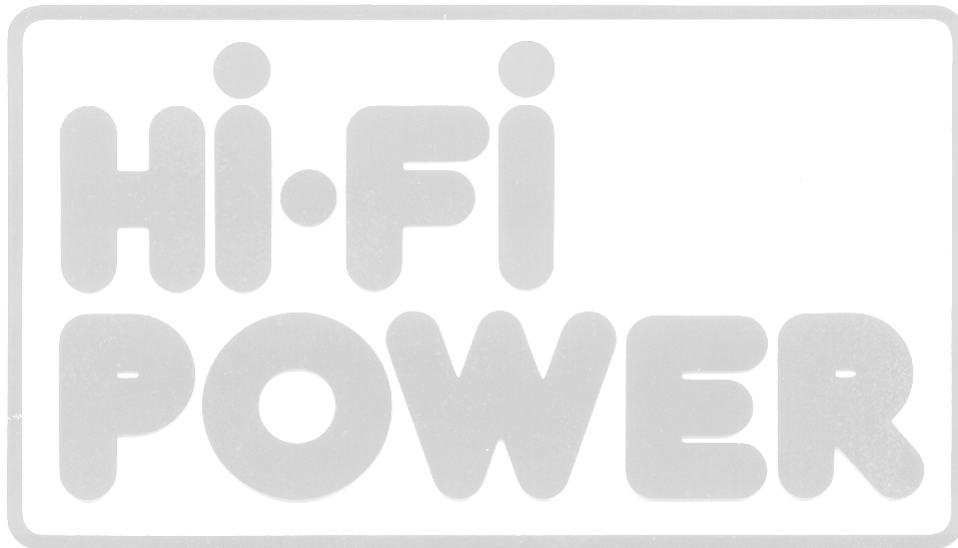
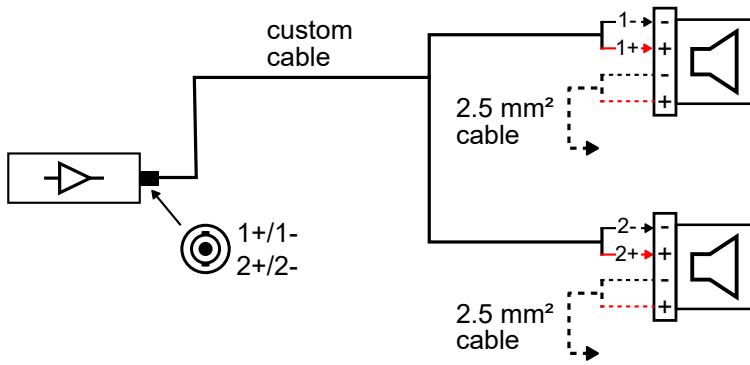

Cabling SB18 Ili

Accessories	connector sealing plates
Screws and fasteners	M5×16 Torx screws (provided)
Tools	torque screwdriver T25 Torx bit small tool or flat screwdriver (3 mm or less)
Min. number of operators	1

Assembly

Prerequisite

- Refer to [Recommendation for speaker cables](#) (p.79).
- Refer to [Cabling schemes](#) (p.55).

About this task

The connector sealing plates have two cable glands: one for the input cable and one for the cable connecting to the next enclosure in parallel. The second cable gland is equipped with a protective plug.

This procedure describes how to connect the input cable to the enclosure. If the enclosure must be connected in parallel, remove the protective plug from the second cable gland and proceed identically for both cables.

Procedure

1. On the connector sealing plate, remove the sealing nut from the cable gland.

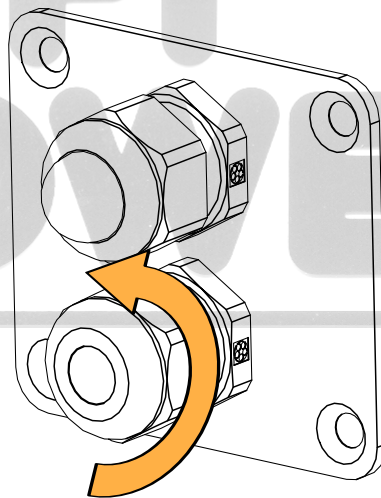

2. Insert the cable through the sealing nut and the cable gland.

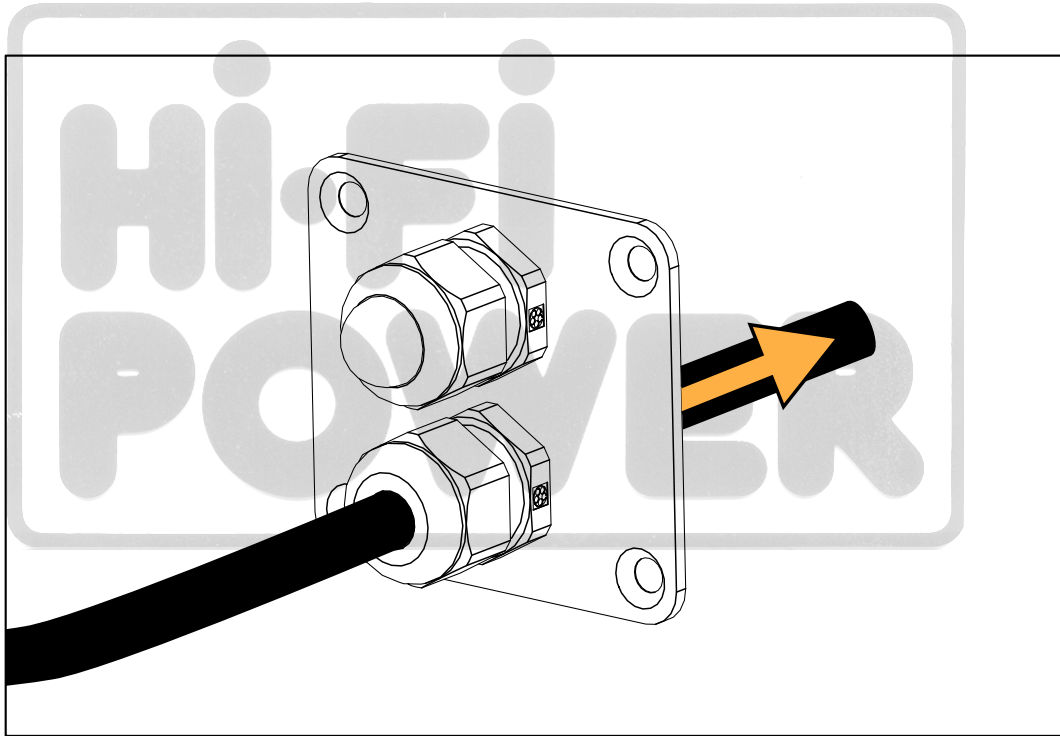
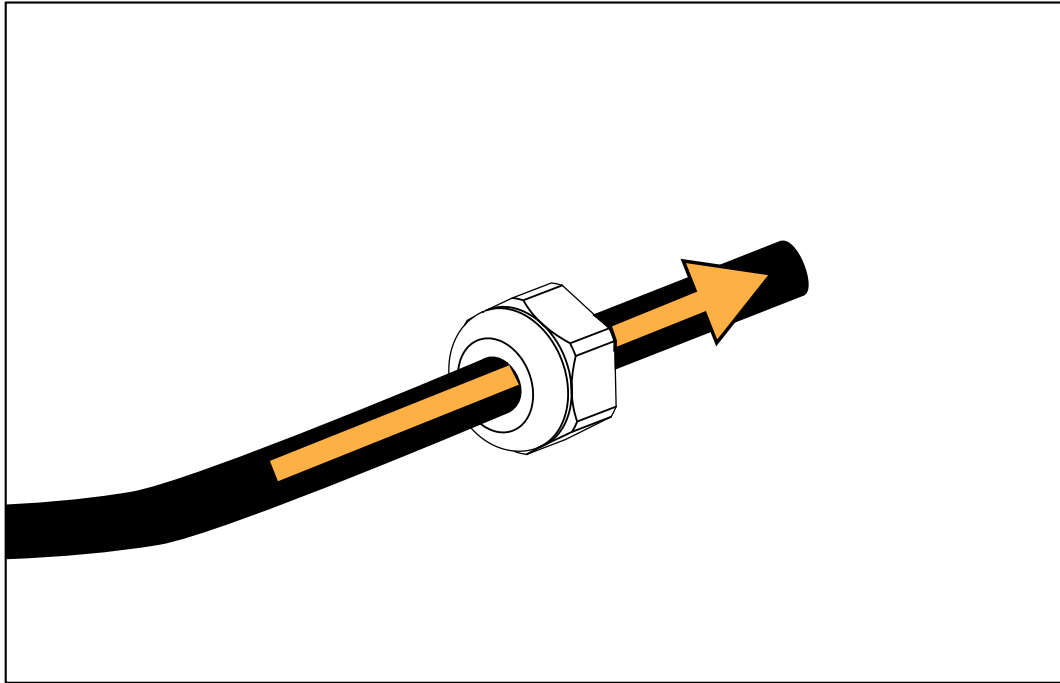

3. Strip the wires off the cable.

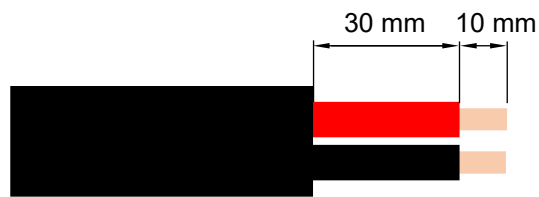

2 x 2.5 mm² cable

! Refer to the cable manufacturer documentation for the wire color code.

4. Push the wires into the terminals.

If necessary, insert a small tool in the hole next to the terminal to unlock it.

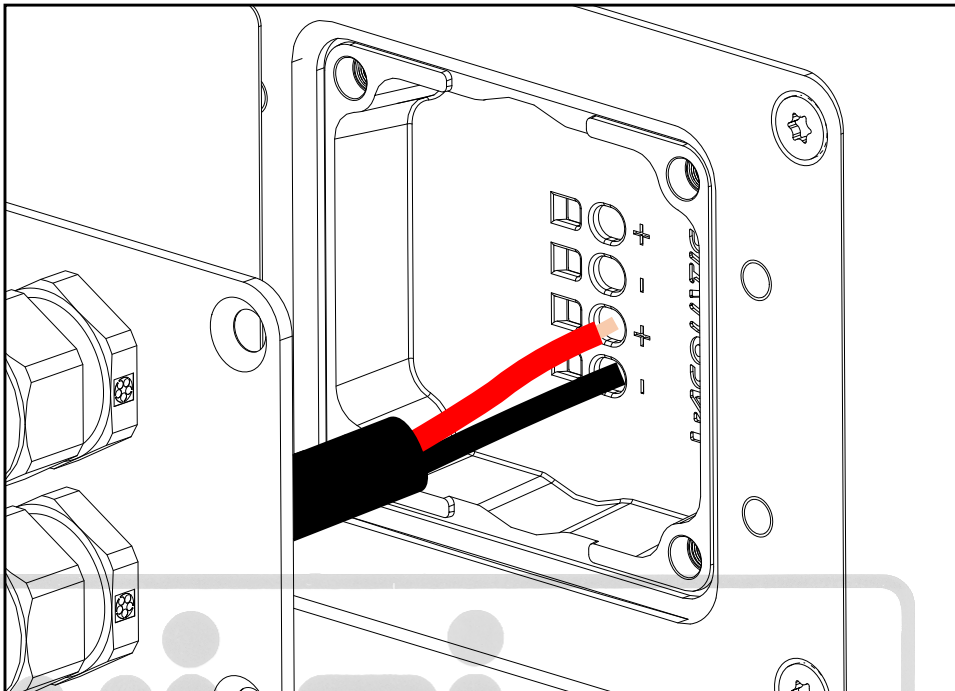

5. Secure the connector sealing plate to the connector plate.

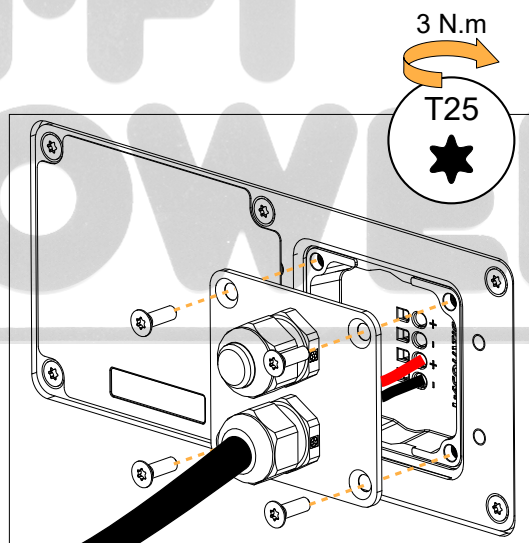

6. Tighten the sealing nut.

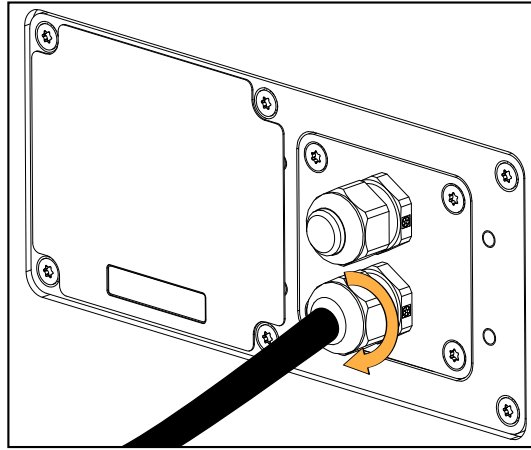

What to do next

To remove the cables, use the small tool to unlock the terminals and pull on the wires.

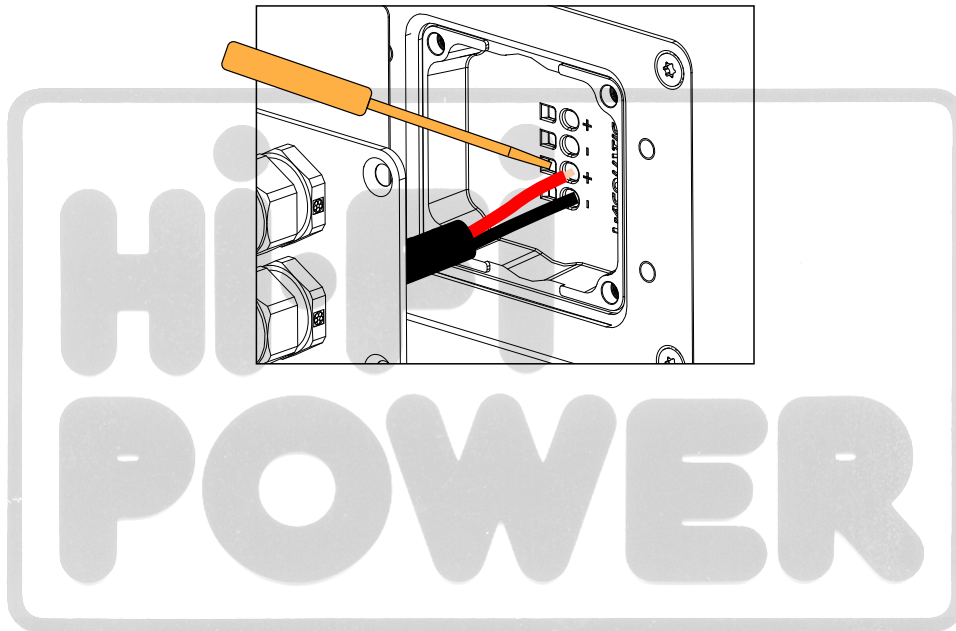

Corrective maintenance

Introduction

This section contains the following maintenance procedures:

SB18 Ili

- [D/R - Grill](#) (p.64)
- [D/R - LF speaker](#) (p.65)

For advanced maintenance, contact your L-Acoustics representative.

Tools

Before performing maintenance on this product, make sure all the tools listed are available. References are given for FACOM® products in this table. Other manufacturers can be used.

name	reference	distributor
set of 6-point 1/4" sockets *	RL.NANO1 / R.360NANO	FACOM
torque screwdriver (2 - 10 N.m) *	A.404	FACOM



* included in the L-Acoustics Maintenance Toolcase.

Maintenance Toolcase

The Maintenance Toolcase is a carry-on suitcase that includes all the tools required to perform maintenance on L-Acoustics products. This toolcase is aimed at Certified Providers.

The Maintenance Toolcase uses a Peli™ 1510 Protector case that features three pre-cut layers of foam to safely fit the tools. The Maintenance Toolcase includes tools manufactured by FACOM®, Fluke®, Tohnichi, ABUS, and Würth.



All third-party trademarks, registered trademarks, or product names are the property of their respective owners.

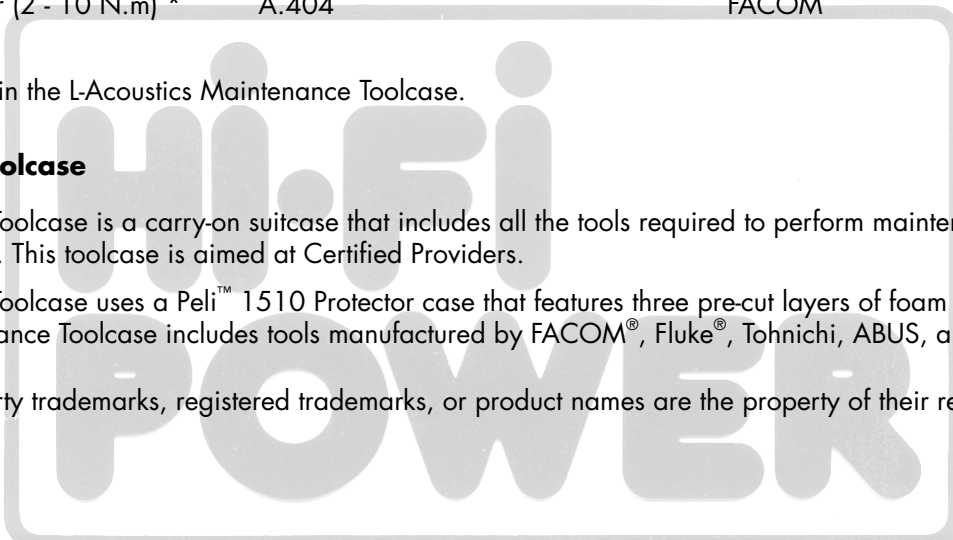

SB18 Ili

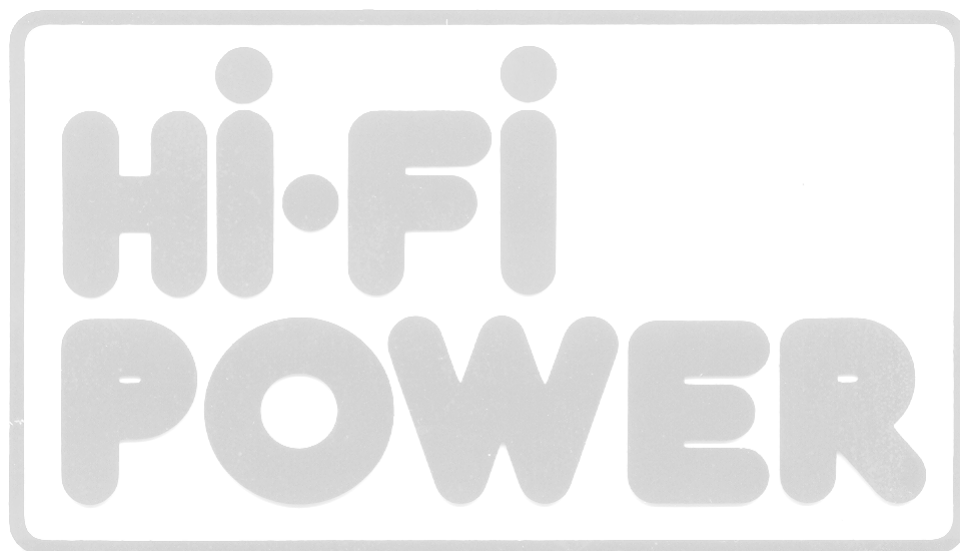

SB18 Ili exploded view

In order to operate, follow the order outlined here. Each assembly refers to the corresponding Disassembly/Reassembly (D/R) procedure and the necessary repair kit.

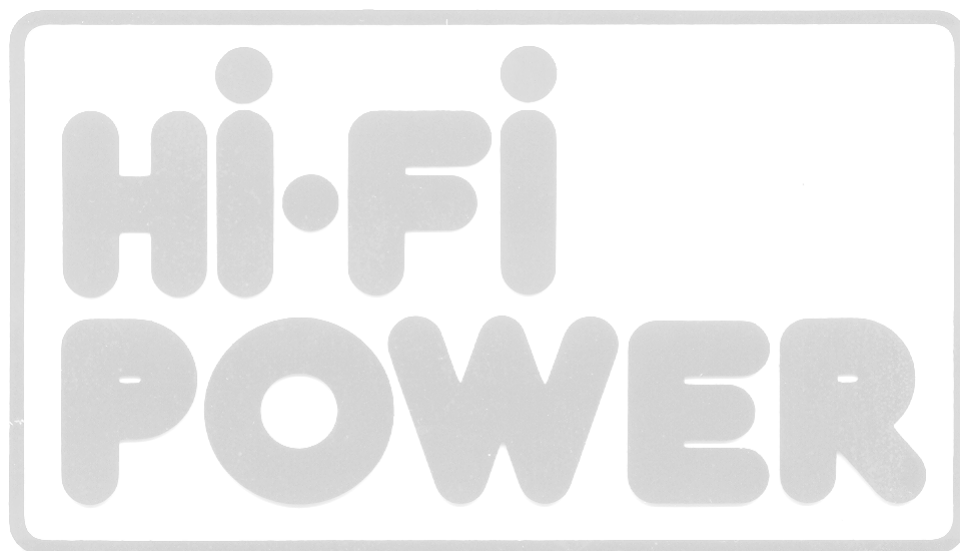
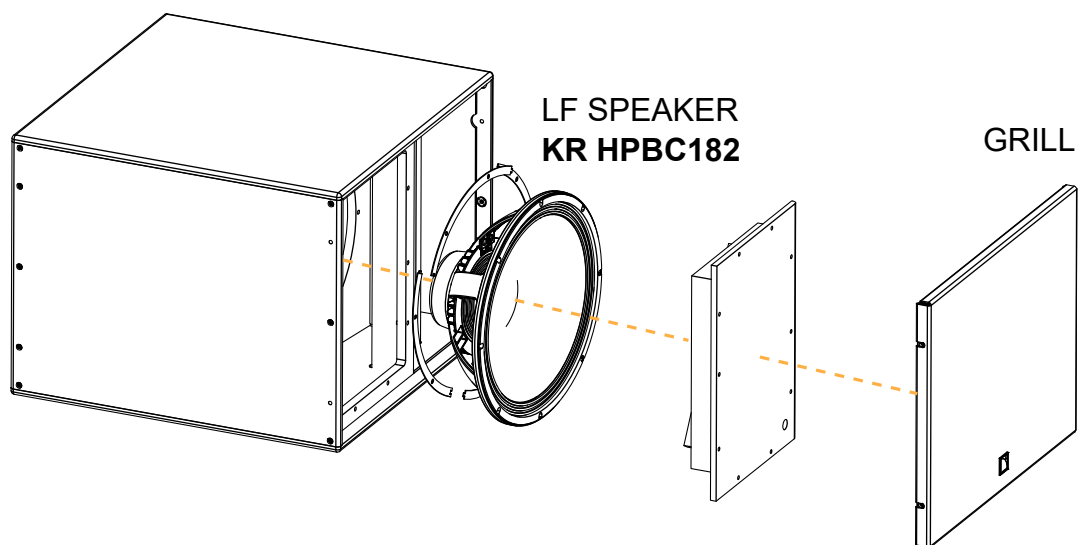

Disassembly and Reassembly procedures

D/R - Grill

Tools

- torque screwdriver
- T30 Torx bit

Repair kit

KR HPBC182

KR 18" loudspeaker SB18(i) / SB18 Ili

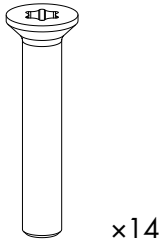

x14

S221

M6x35 Torx

Exploded view



For safety reasons, always use the new screws and spare parts provided in the KR.
If no new screws are available, use blue threadlocker.

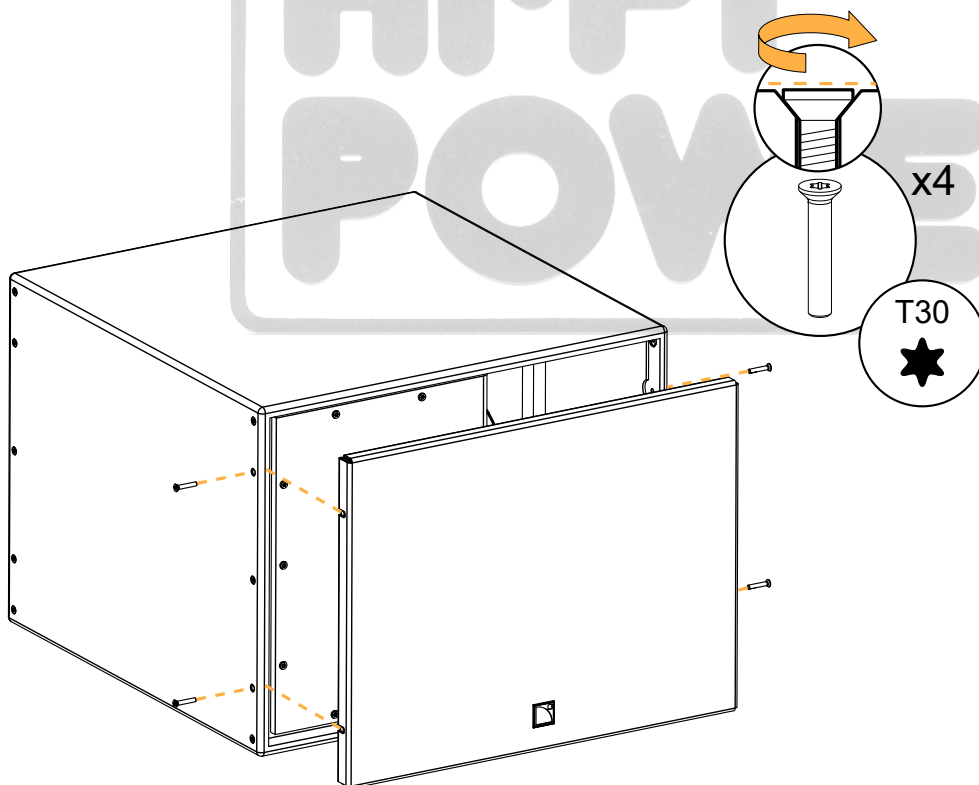

D/R - LF speaker

Tools

- torque screwdriver
- T30 Torx bit
- 5 mm hex bit

Repair kit

KR HPBC182

KR 18" loudspeaker SB18(i) / SB18 Ili

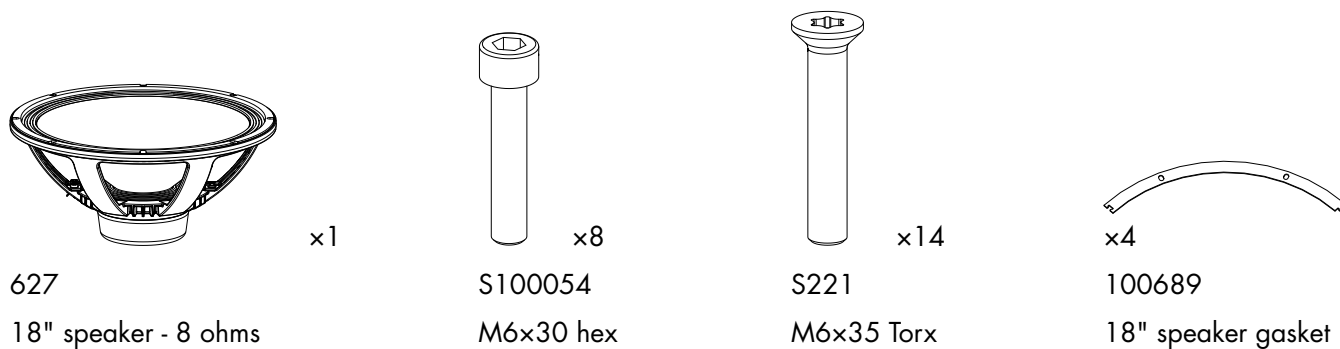

Prerequisite

Grill removed.

See [D/R - Grill](#) (p.64).

Disassembly

Procedure

1. Remove the plate.

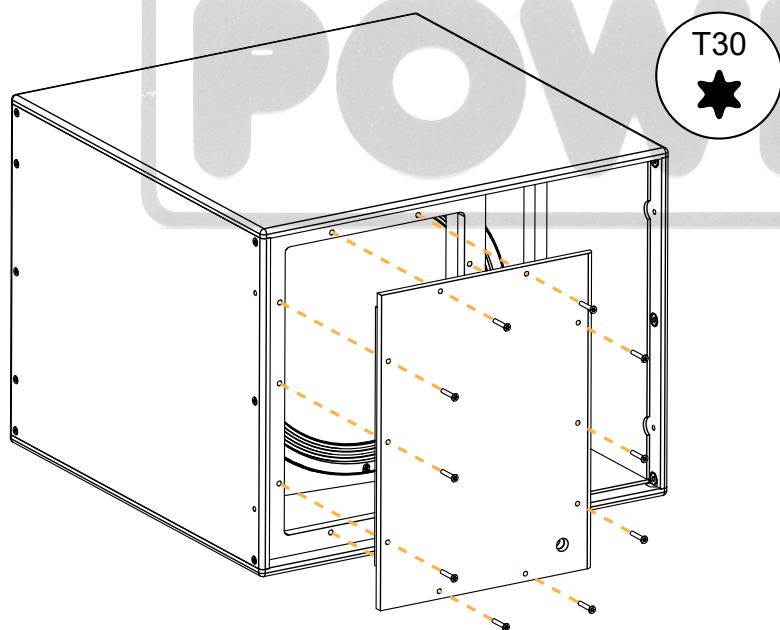

2. Remove the speaker screws.

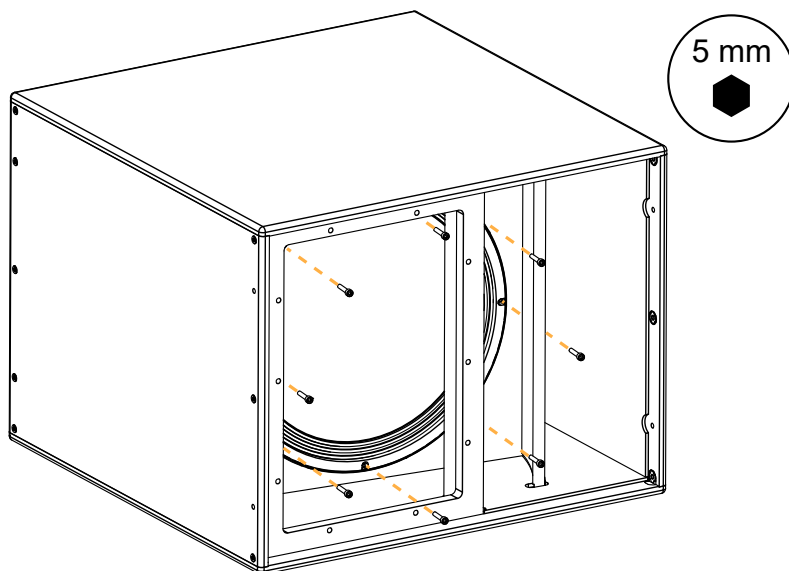

3. Remove the speaker from the enclosure and disconnect the speaker cables.

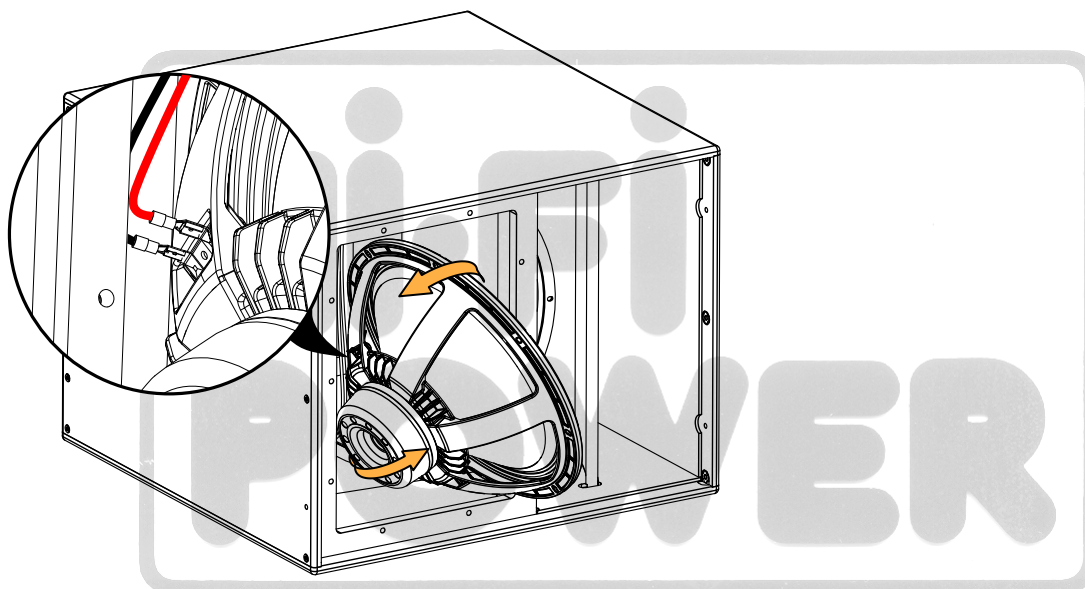

4. If the speaker gaskets are damaged, remove and replace them.

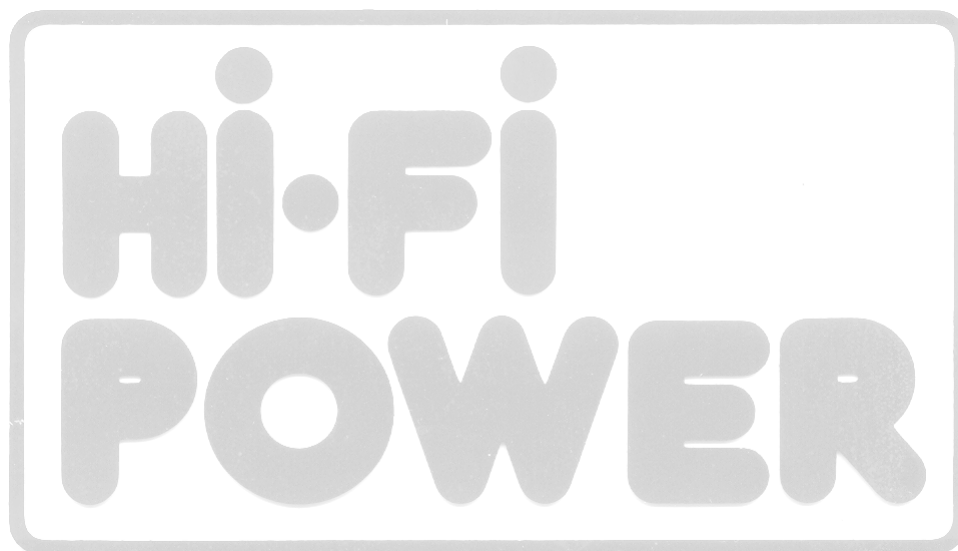
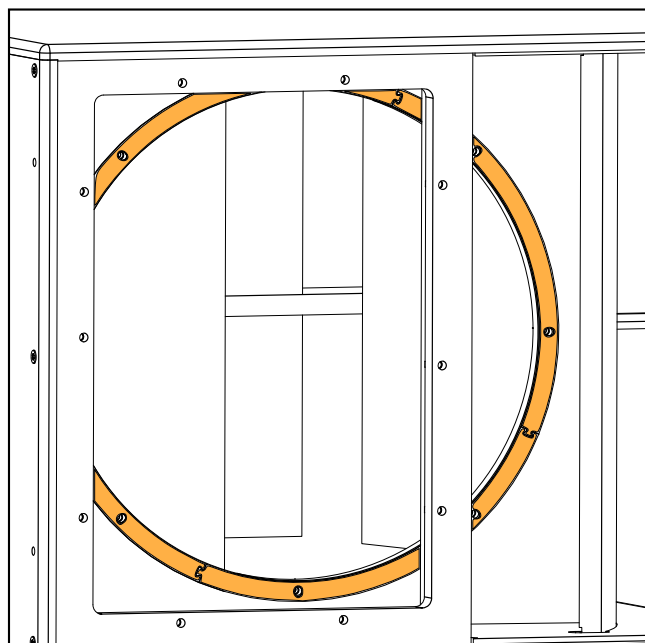

Reassembly

About this task

- ! For safety reasons, always use the new screws and spare parts provided in the KR. If no new screws are available, use blue threadlocker.

Procedure

1. Connect the speaker cables and position the speaker in the enclosure.

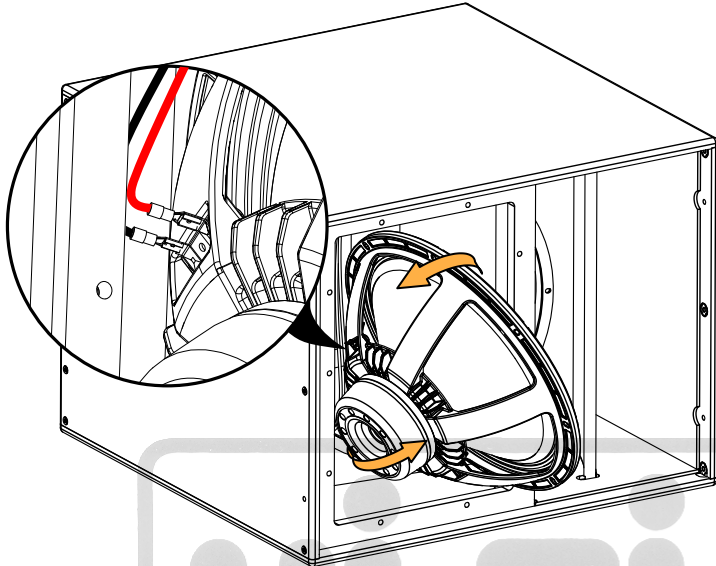

2. Secure the speaker.

- ! Gradually tighten the screws following a star pattern.

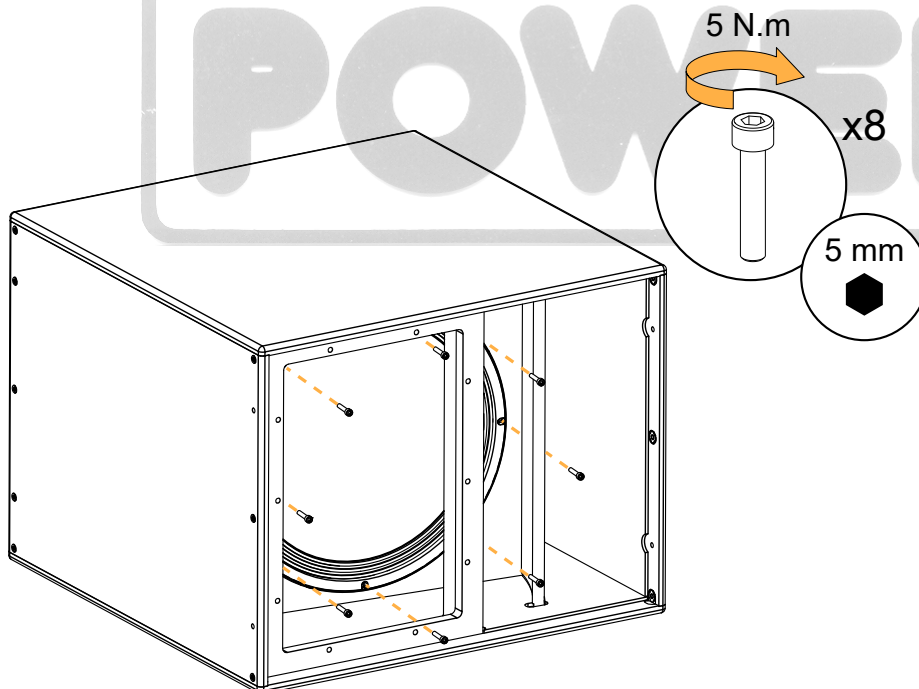

3. Secure the plate.

 Gradually tighten the screws following a star pattern.

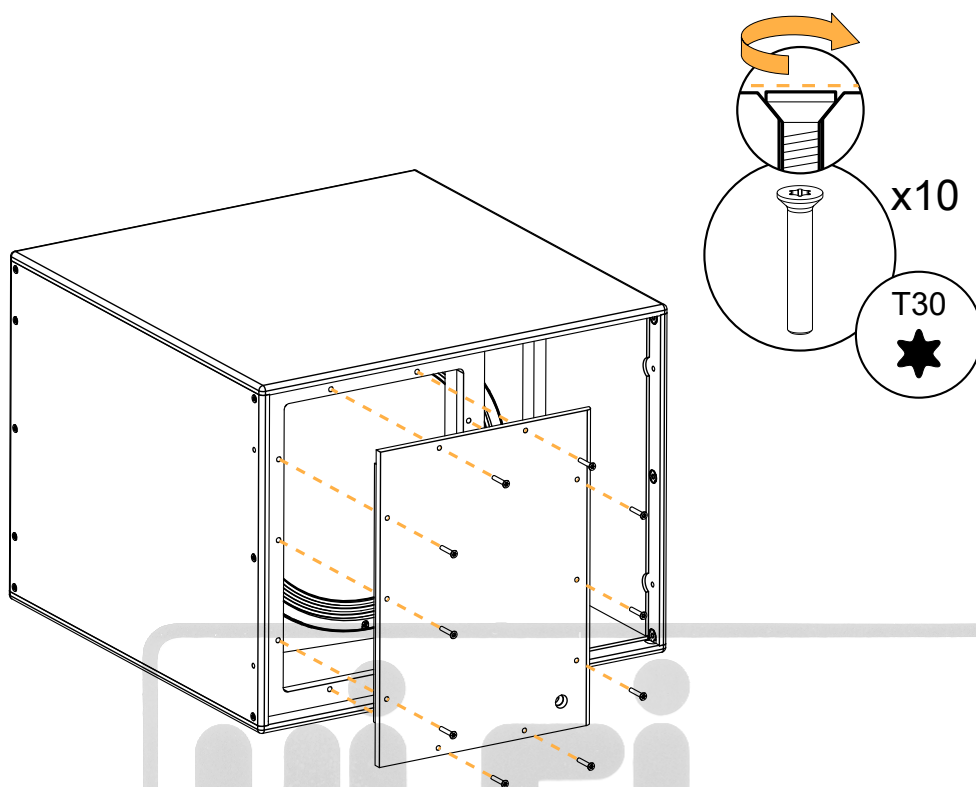
**What to do next**

Perform the [Acoustical check](#) (p.30) procedures.

HI-FI
POWER

D/R - Connector sealing plate

Tools

- torque screwdriver
- T25 Torx bit
- small tool or flat screwdriver (3 mm or less)

Repair kit

Prerequisite

Refer to the owner's manual for more information on cabling schemes.

Exploded view



For safety reasons, always use the new screws and spare parts provided in the KR. If no new screws are available, use blue threadlocker.

About this task

The connector sealing plates have two cable glands: one for the input cable and one for the cable connecting to the next enclosure in parallel. The second cable gland is equipped with a protective plug.

This procedure describes how to connect the input cable to the enclosure. If the enclosure must be connected in parallel, remove the protective plug from the second cable gland and proceed identically for both cables.

Procedure

1. On the connector sealing plate, remove the sealing nut from the cable gland.

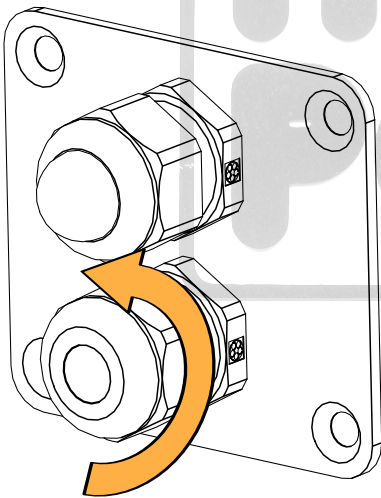

2. Insert the cable through the sealing nut and the cable gland.

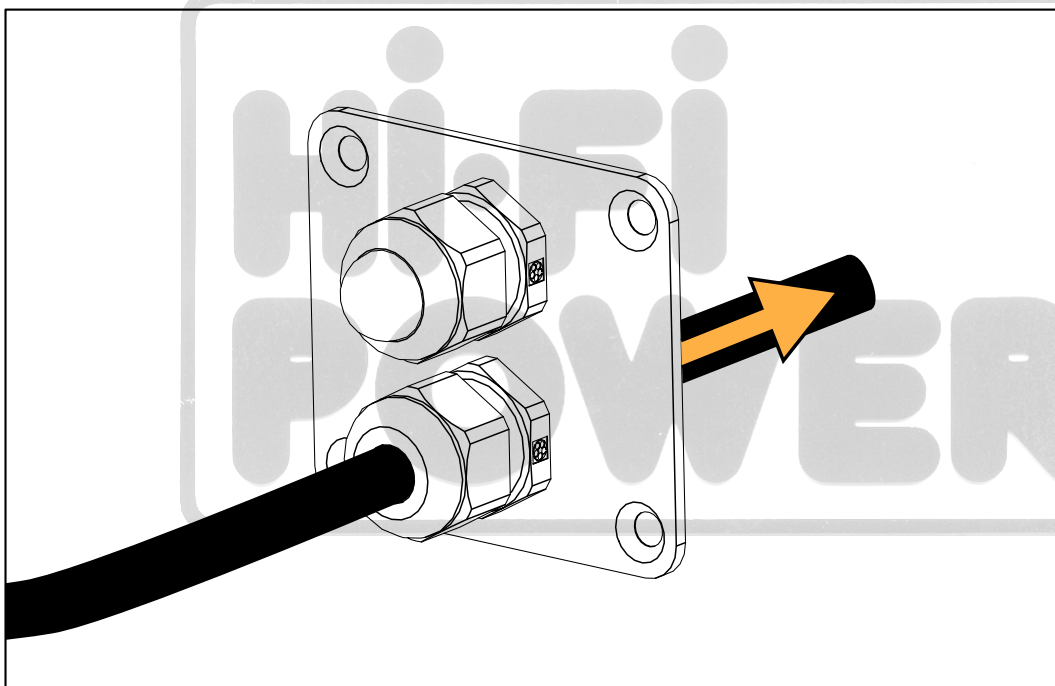
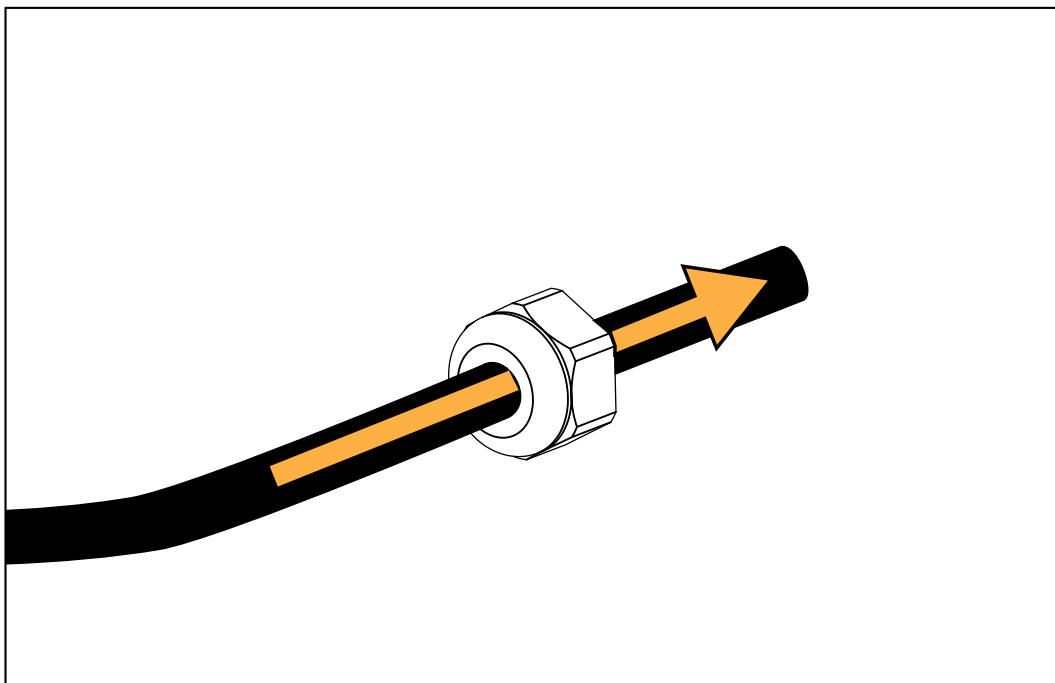

3. Strip the wires of the cable.



Refer to the cable manufacturer documentation for the wire color code.

4. Push the wires into the terminals.

If necessary, use a small tool in the hole next to the terminal to unlock it.

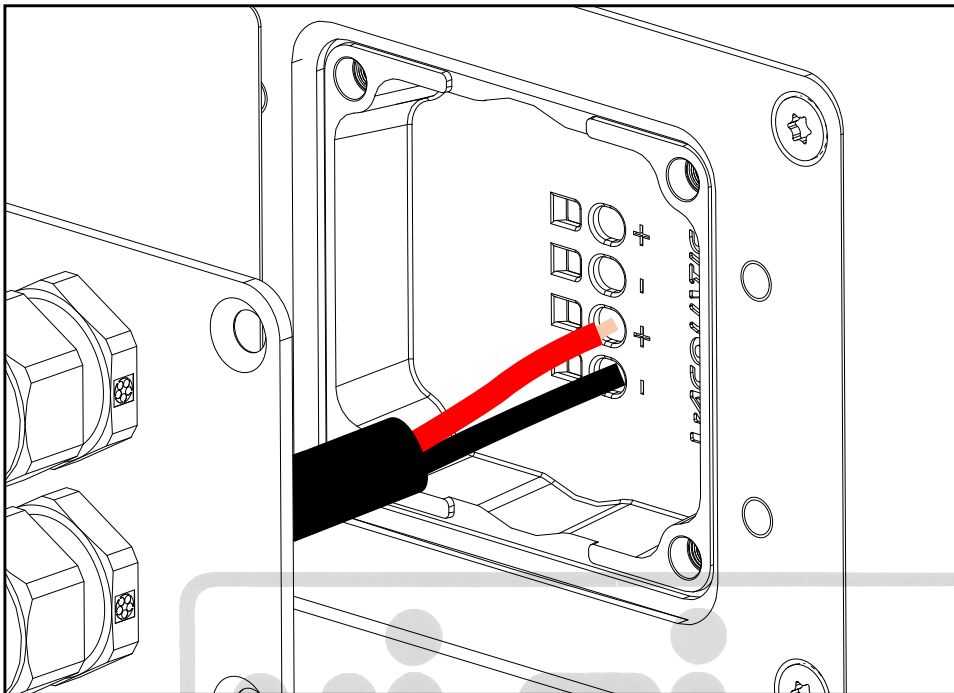

5. Secure the connector sealing plate to the connector plate.

6. Tighten the sealing nut.

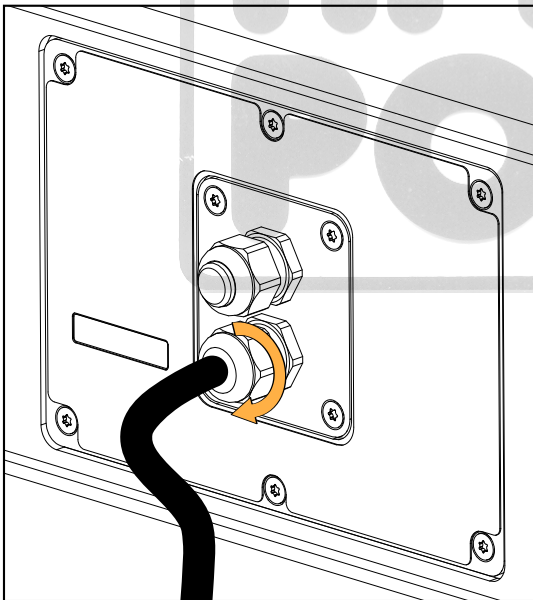

What to do next

To remove the cables use the small tool to unlock the terminals and pull on the wires.

Specifications

SB18 Ili specifications

Description	High power compact subwoofer: 1 x 18" (installation version), amplified by LA2Xi / LA4X / LA8 / LA12X
Low frequency limit (-10 dB)	32 Hz ([SB18_100])
Maximum SPL¹	138 dB ([SB18_100]) with LA2Xi (bridge mode) / LA4X / LA8 / LA12X 133 dB ([SB18_100]) with LA2Xi
Directivity	standard or cardioid
Transducers	1 x 18" cone driver
Acoustical load	dual bass-reflex
Nominal impedance	8 Ω
Connectors	1 x 4-point terminal block with push-in connection
Rigging and handling	external rigging kits 12 M6 inserts for rigging 8 M6 inserts for screens
Weight (net)	48 kg / 106 lb
Cabinet	premium grade Baltic birch plywood
Front	coated steel grill acoustically neutral 3D fabric
Finish	dark grey brown Pantone 426 C pure white RAL 9010 custom RAL code on special order
IP	IP55

¹ Peak level at 1 m under half space conditions using pink noise with crest factor 4 (preset specified in brackets).

SB18 Ili dimensions

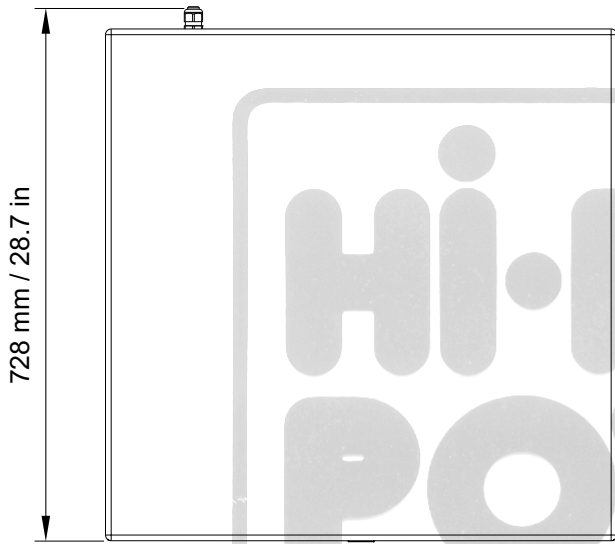
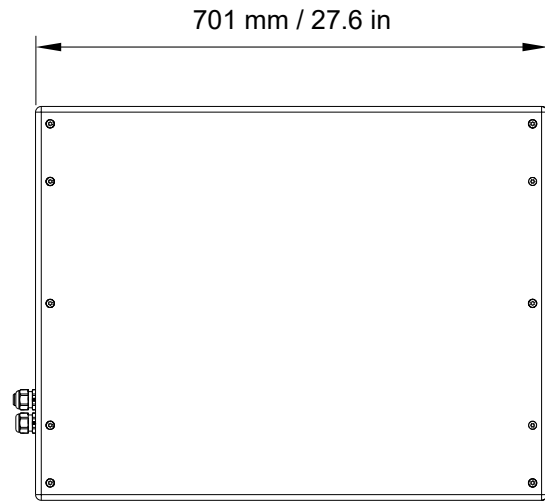
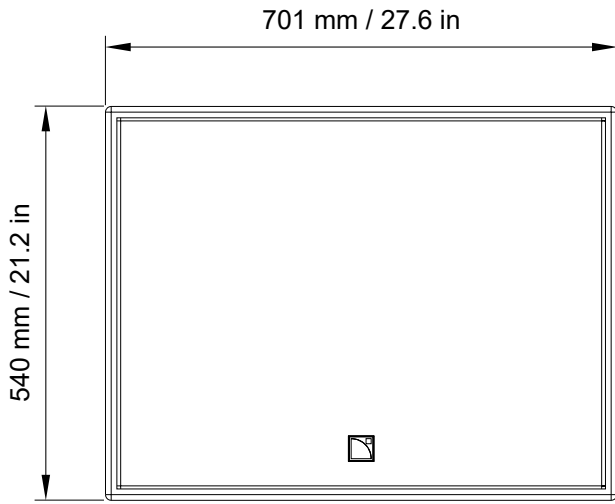

M-BARi specifications

Description	Extension bar for rigging frame (installation version)
Weight (net)	5 kg / 11 lb
Material	high grade steel with anti-corrosion coating

M-BARi dimensions

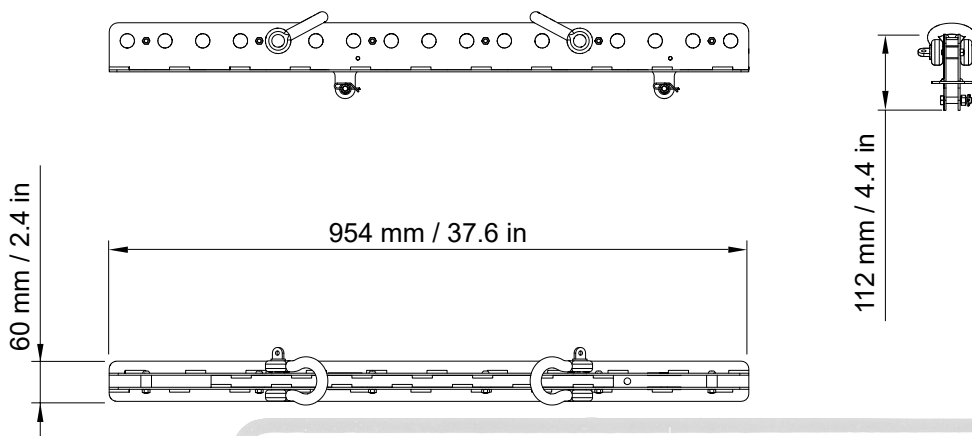

KARAIi-RIGBAR specifications

Description	Rigging bar and pullback for Kara Ili and SB18 Ili 2 x Ø12 mm shackles WLL 1 t
Weight (net)	4.8 kg / 11 lb
Material	high grade steel with anti-corrosion coating

KARAIi-RIGBAR dimensions

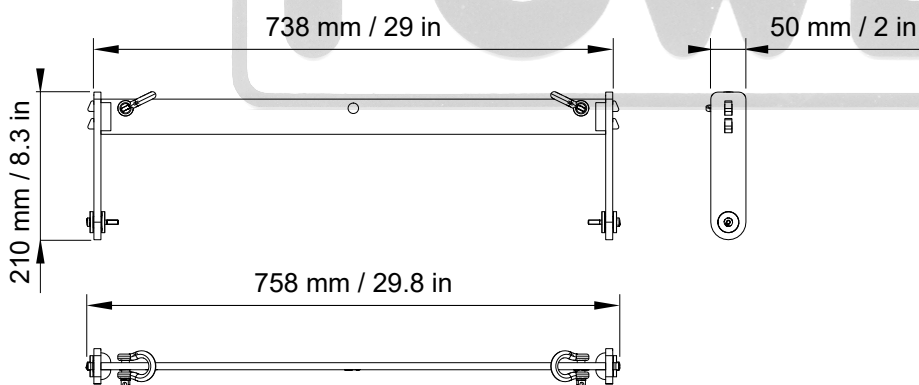

KARAlli-BUMP specifications

Description	Flying frame for vertical deployment of Kara Ili and SB18 Ili 2 x Ø19 mm shackles WLL 3.25 t
Weight (net)	21 kg / 46 lb
Material	high grade steel with anti-corrosion coating

KARAlli-BUMP dimensions

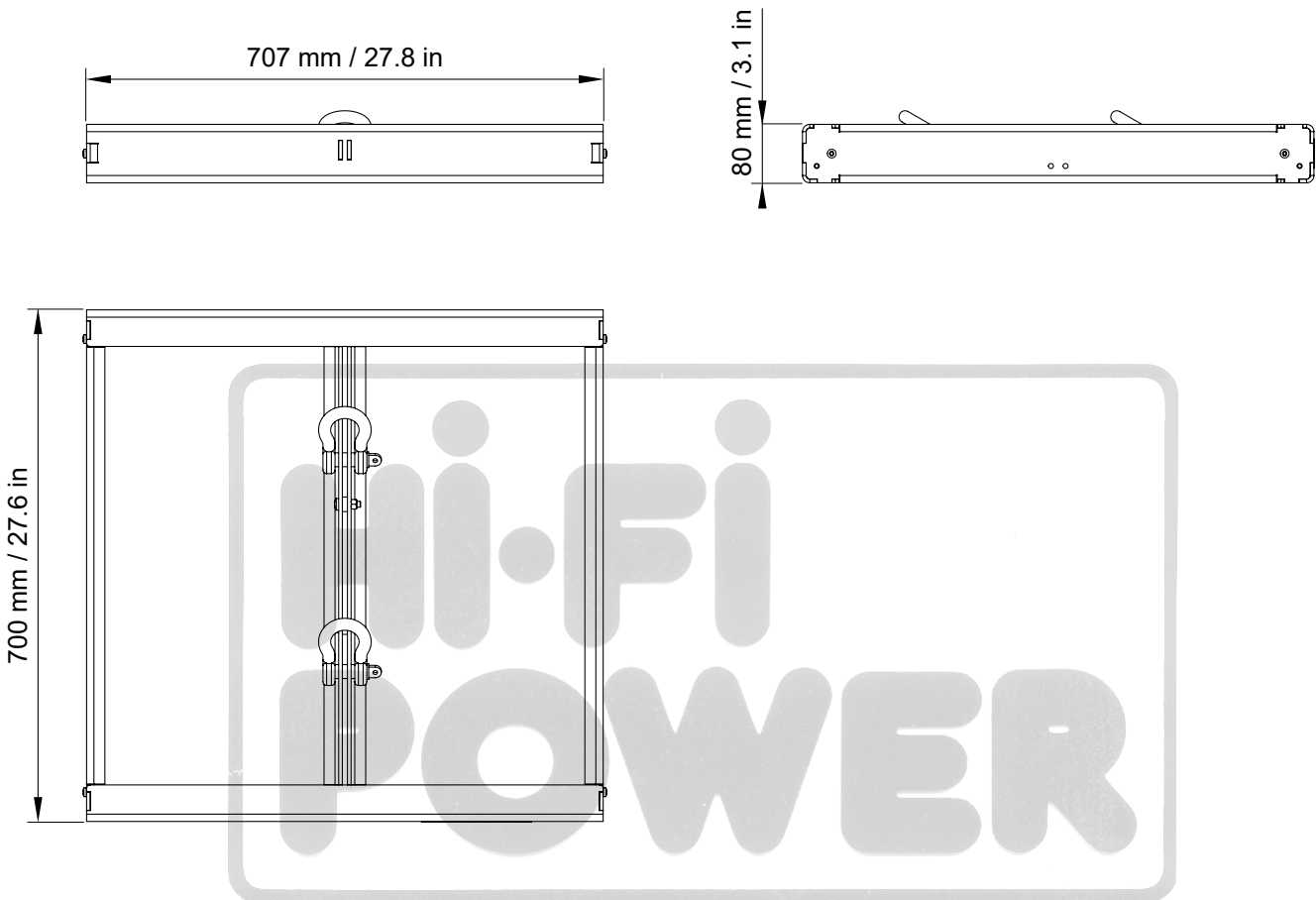

KARAIi-FIXBRACKET specifications

Description	Fastening brackets for Kara Ili and SB18 Ili
Weight (net)	0.5 kg / 1.1 lb
Material	high grade steel with anti-corrosion coating

KARAIi-FIXBRACKET dimensions

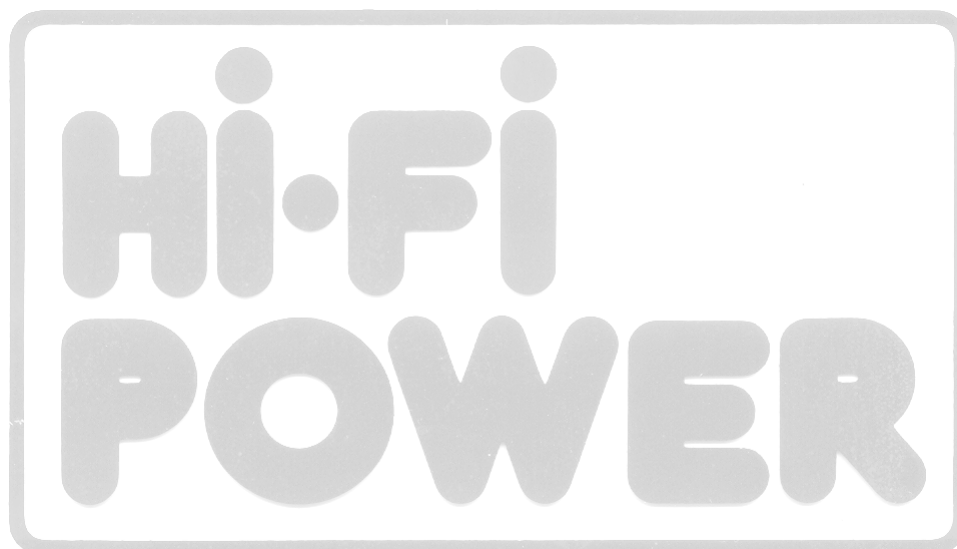
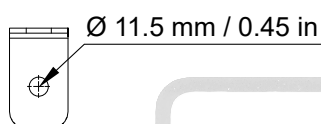
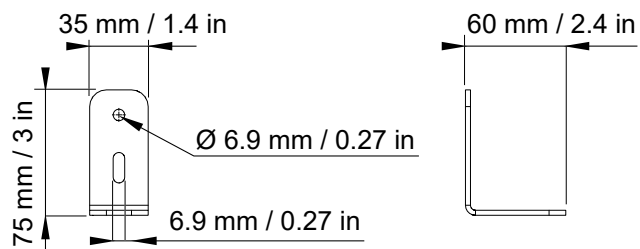

CLAMP250 specifications

Description	Clamp certified for 250 kg
Weight (net)	1.8 kg / 4 lb
Material	high grade steel with anti-corrosion coating

CLAMP250 dimensions

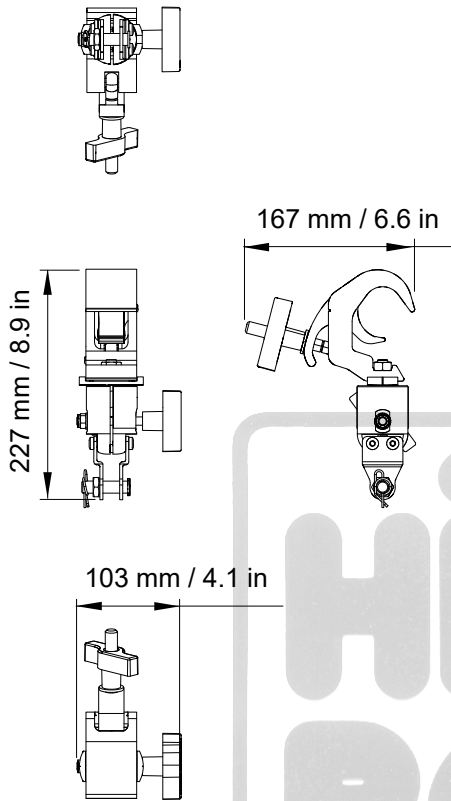

SB18Ili-SCREEN specifications

Description	Acoustically transparent front screen for SB18 Ili
Weight (net)	2.7 kg / 6 lb

SB18Ili-SCREEN dimensions



Recommendation for speaker cables

Follow the recommended maximum length for loudspeaker cables to ensure minimal SPL attenuation.

! Cable quality and resistance

Only use high-quality fully insulated speaker cables made of stranded copper wire.

Use cables with a gauge offering low resistance per unit length and keep the cables as short as possible.

The table below provides the recommended maximum length for loudspeaker cables depending on the cable gauge and on the impedance load connected to the amplifier.

cable gauge			recommended maximum length					
			8 Ω load		4 Ω load		2.7 Ω load	
mm ²	SWG	AWG	m	ft	m	ft	m	ft
2.5	15	13	30	100	15	50	10	33
4	13	11	50	160	25	80	17	53
6	11	9	74	240	37	120	25	80

Use the more detailed L-Acoustics calculation tool to evaluate cable length and gauge based on the type and number of enclosures connected. The calculation tool is available on our website:

<https://www.l-acoustics.com/installation-tools/>



Specifications for custom rigging systems

Dimensions

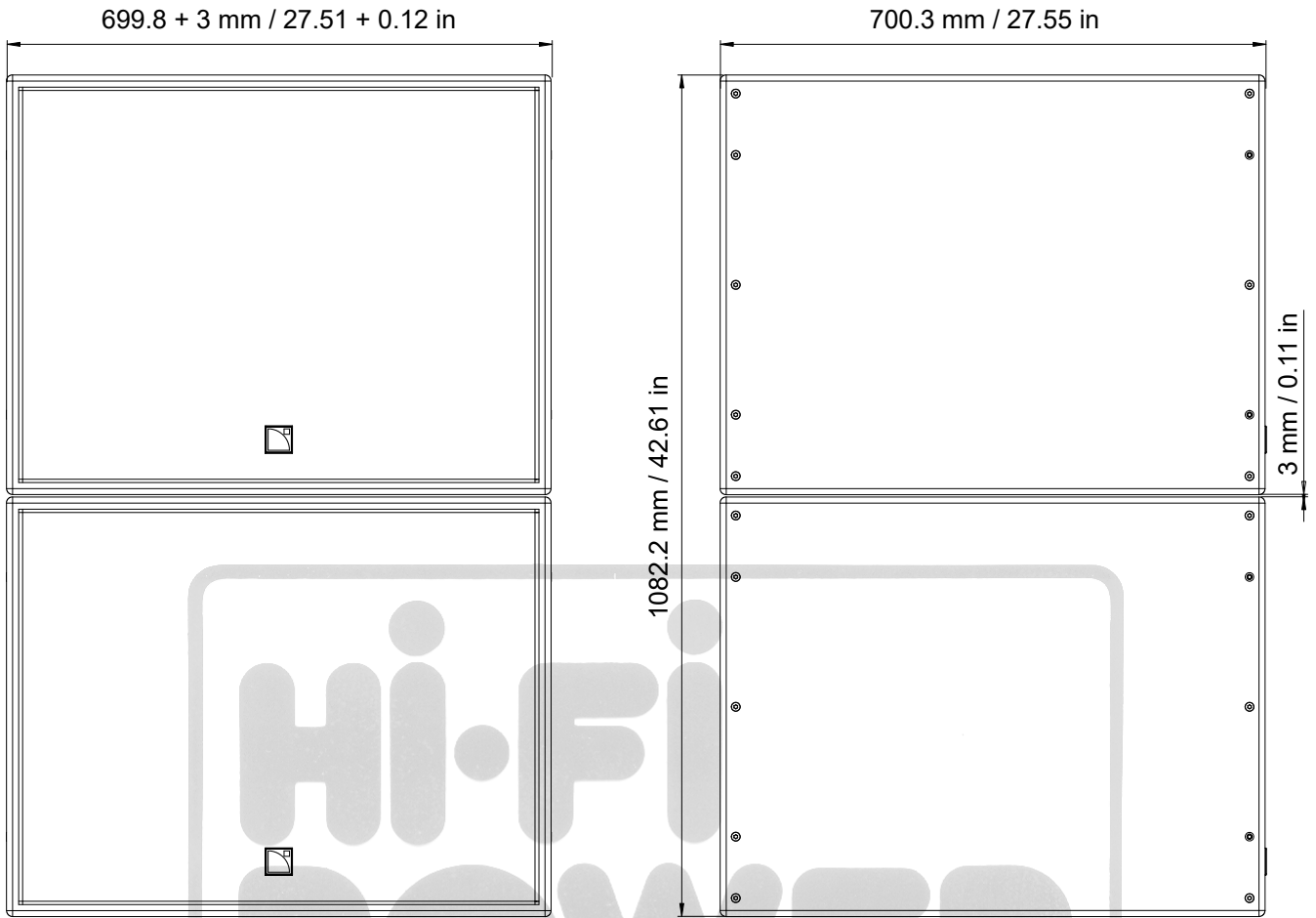

Center of gravity

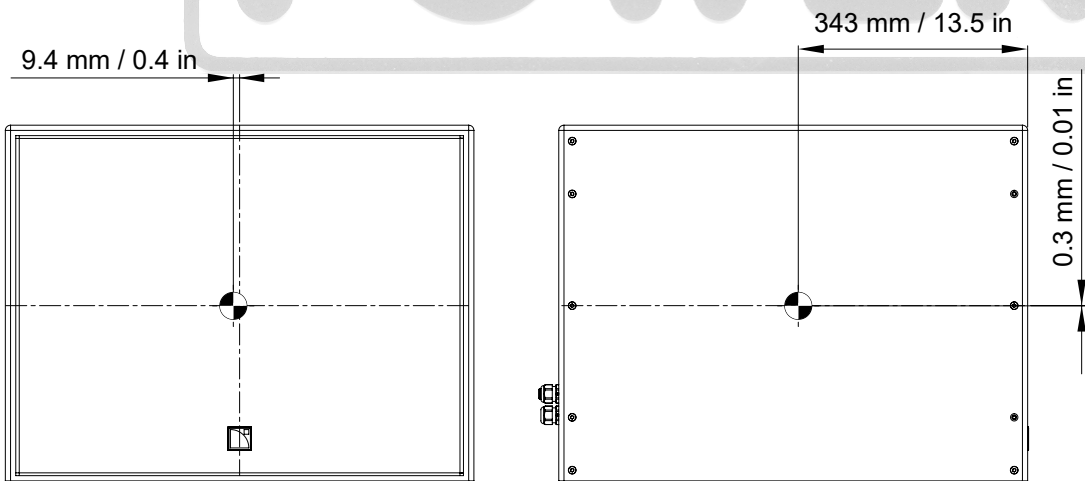

Threaded inserts and screws



Use only rigging inserts to implement a custom rigging

Inserts marked with  can be used for rigging.

Inserts marked with  must not be used for custom rigging (reserved for screen mounting, maintenance purposes, L-Acoustics accessories, etc.).



Grade of screws must be defined by a qualified person

Take into consideration the number of inserts used, weight and center of gravity of enclosure(s), and resulting action forces.

Prevent screws from loosening (threadlocker, spring washer...).

SB18 Ili has **8 threaded M6 inserts** available for rigging.

	M6 standard inserts
Ultimate Tensile Strength	1160 N
Ultimate Shear Strength	4250 N
Recommended screw length*	min 18 mm / 0.7 in.
Recommended torque	5 N.m



*Recommended screw length for a metal sheet with a thickness of 3 mm / 0.1 in. Adapt the length to the custom rigging design.

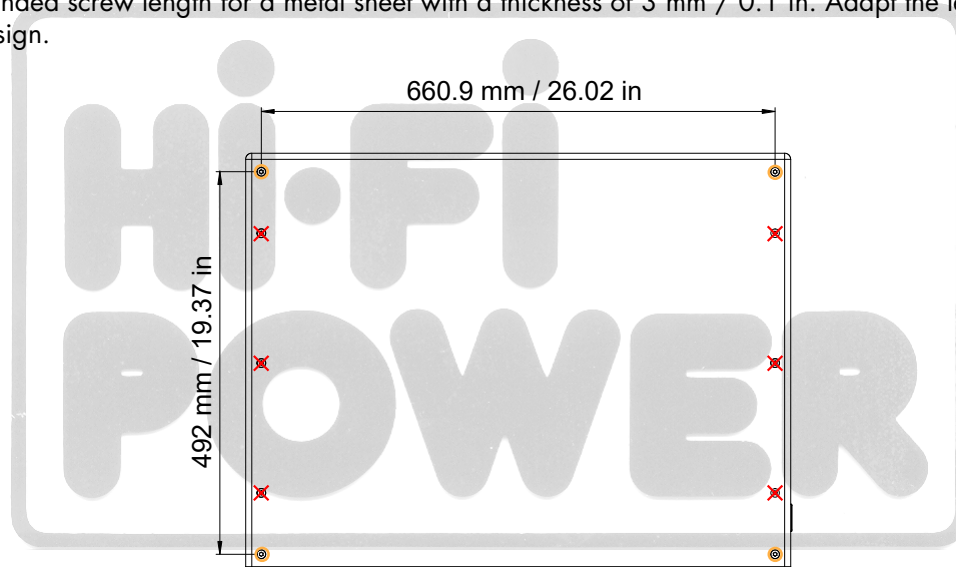



L-Acoustics

13 rue Levacher Cintrat - 91460 Marcoussis - France

+33 1 69 63 69 63 - info@l-acoustics.com

www.l-acoustics.com

Hi-Fi
POWER

 **L-ACOUSTICS**
GROUP

**Hi-Fi
POWER**

HOME &
PROFESSIONAL
AUDIOVISUAL

• MAPNH 8 ΑΘΗΝΑ 10433 • ΤΗΛ. 210 3845676 – 210 3845272 FAX. 210 3809747 • e-mail: sales@hifipower.gr •