

XRT1.1K
Loudspeaker System
Owner's Manual





Safety First

Please read the Safety Instructions included in a separate document called “Important Additional Operation Information Guide.”



Introduction

The XRT1.1K Loudspeaker System is the next evolution in Loudspeaker design.

High-end Loudspeaker development is a marriage of art and science. The XRT1.1K is the culmination of decades of work (and—we must admit—play). Since the early 1970s, engineers at McIntosh have been performing painstaking loudspeaker research and development—examining minute changes as well as exploring new technologies. An example of utilizing innovation is the XRT1.1K’s use of McIntosh’s patented Line Array Technology which, among other benefits, provides superior sonic dispersion. The latest sound principles and the highest quality components combine to deliver strikingly realistic sound with exquisite detail and imaging. Combining all these elements to produce the most musical output possible is the art of this mission. The result is this masterpiece of sound reproduction. Enjoy!

Table of Contents

Safety First.....	2
Introduction.....	2
Thank You from All of Us at McIntosh	3
Make a Note.....	3
Experts Standing By	3
Unpacking.....	3
Speaker Placement.....	4
Assembling The XRT1.1K	4
Installation	5
Prepare the Speaker Wire.....	5
Loudspeaker Input Terminal Connection.....	5
Single Amplifier Connection.....	5
Multiple Amplifier Connections.....	5
Less Resistance.....	5
Making It Glow.....	5
Part Numbers for Packing Material	6
Cleaning and Care.....	6
Packing it Up.....	6
What's Inside	7
More About Line Array	7
The Crossover Network	7
Driver and Port Locations.....	8
Dimensions	9
Specifications.....	10

List of Figures

Directional Label.....	4
Attaching Mid/Tweeter Column.....	4
Opening Input Terminal	5
Tightening Input Post	5
Jumper Cable	5
Power Control Connection.....	6
Array Packaging.....	6
Power Control Jack.....	6
Woofer Column Packaging.....	6
Driver and Port locations.....	8
Dimensions	9

Thank You from All of Us at McIntosh

You have invested in a precision instrument that will provide you with many years of enjoyment. Please take a few moments to familiarize yourself with the features and instructions to get the maximum performance from your equipment.

Make a Note

For future reference, you can write your serial number and purchase information here. We can identify your purchase from this information if the occasion should arise.

Serial Number:	
Purchase Date:	
Dealer Name:	

Experts Standing By

If you need further technical assistance, please contact your McIntosh Dealer who may be more familiar with your particular setup including other brands. You can also contact us at McIntosh with additional questions or in the unlikely event of needing service.

McIntosh Laboratory, Inc.
2 Chambers Street
Binghamton, New York 13903
Phone : (607) 723-3512 (Technical Assistance)
Phone: (607) 723-3515 (Customer Service)
Fax: 607-724-0549 (Customer Service)
support@mcintoshlabs.com

Website: mcintoshlabs.com

Copyright 2018 © by McIntosh Laboratory, Inc

Unpacking

Each Loudspeaker comes in two boxes (for a total of four boxes for a pair). The main speaker column is VERY HEAVY. Take care and do not move this VERY HEAVY speaker column alone. Please have sufficient help to safely handle this substantial investment. Your McIntosh Dealer is quite experienced in such installations and is a recommended resource for this task. Either way, please use caution and care in handling these speakers.

To remove the speaker column from the carton:

- Remove banding that is holding boxes in place.
- Place the large speaker box on its back so that the top of the box can be lifted off. (This is how the box was sitting on the shipping pallet.)
- Remove the top of the box by lifting upward.
- Remove the parts box and other pieces such as this manual, leaving packing material in place.
- Carefully, roll the carton over so that the open side is on the bottom, preferably on a carpet or other soft surface.
- Lift the box up and off the speaker column.
- Remove the packing material from the speaker's base.
- Carefully lift the XRT1.1K up so that it rests on its base.
- Remove remaining packing material.
- You may choose to place the speaker in its intended location before attaching the Tweeter/Midrange Driver Column.

Speaker Placement

A rule of thumb for speaker placement is to form a triangle with the distance between Loudspeakers no greater than the distance of each Loudspeaker from the main listening position (which should be equal). With the Line Array speaker design of the XRT1.1K, there will be a much larger area of prime listening positions outside of the typical sweetspot.

Due to the unique qualities of each listening space, a certain amount of trial and error is expected to achieve the ultimate placement. With ports in the rear of the speaker, it is important that the speaker not be placed against the rear wall. Side wall proximity will also affect sound as do large comfy couches.

One formula used to determine minimum distance from the wall for a speaker is: Distance from rear wall in inches = total square inches of rear ports. In this case, the answer for the minimum distance an XRT1.1K should be from the rear wall is about 37.7 inches (95.8cm).

Needless to say, because there is a left and right version of the XRT1.1K, it is highly recommended that the right speaker be on the listener's right and the left on the left. To do anything else would be to ignore countless hours of design work.

Some people like to toe-in their speakers. That should not be necessary with the XRT1.1Ks.

When moving the XRT1.1K, remember they are what we in the industry call "VERY HEAVY." Get help when moving these speakers to avoid hurting yourself or the speakers.

Assembling The XRT1.1K

The goal is to attach the Tweeter/Midrange Driver Column to the Larger Woofer Column. First, remove the Tweeter/Midrange Driver Column from

the smaller box and all packing material.

Assuming you have a pair of XRT1.1Ks, take note as to which is the right speaker and which is the left for both parts. Right should attach to right and left to left. (Right and left are from the position of a listener looking at the front of the speakers.) There will be a label on the back of the Tweeter/Midrange Column with an arrow facing upward to determine the correct orientation as well as a Left/Right designation (*Figure 2*). The Right XRT1.1K Woofer Column will have the Red Connector Cables hanging on the right side and the left will have the Red Connector Cables hanging on the left side.

Locate the accessory box which contains fasteners and the tool needed for this task. Each side will require 4 lock nuts and 4 magnetic covers.

For each side:

1. Remove the protective rubber tips from the four pre-installed bolts. (A pair of bolts protrude from each of two metal plates in the front of the woofer column.)
2. Carefully, position the Tweeter/Midrange Column over the four bolts. (*Figure 1*).
3. Place a lock nut on each bolt.
4. Using the supplied lock nut driver tool, tighten the four Lock Nuts. **Do Not Over Tighten.** When snug, stop.
5. Cover each tightened lock nut with a magnetic cover.
6. Now, connect the two upper and two lower cables into the sockets on the back of the Midrange/Tweeter Column. Red color coded labels mark the red cable connectors.



Figure 2– Directional Label

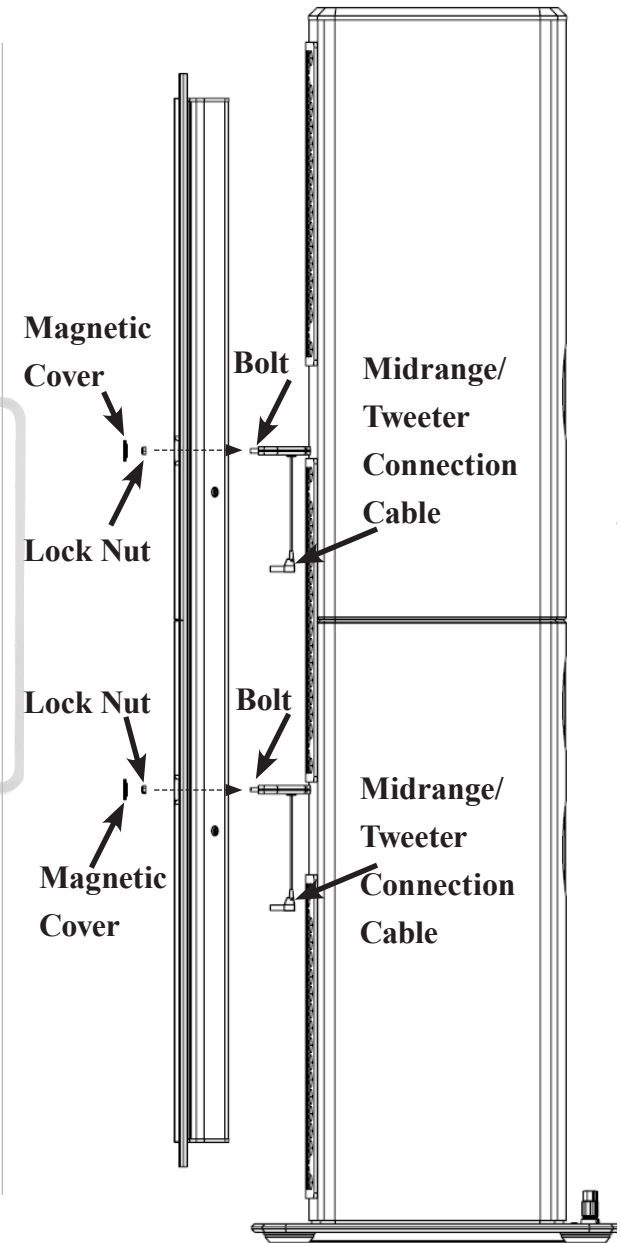

Figure 1– Attaching Mid/Tweeter Column

Installation

Prepare the Speaker Wire

- If speaker wire is not already terminated, remove ½ inch (12.7 mm) of insulation from the wire end and twist the strands together. For runs under 25 feet, use at least 16AWG wire. For runs under 50 feet use at least 14AWG, and for longer runs up to 100 feet, use 12AWG. 12AWG, being the larger wire, can be used in all the above cases if desired. The above guidelines are for 8 Ohm connections. **The XRT1.1K is an 8 Ohm speaker**, but, for reference purposes, when using 4 Ohm speaker connections, subtract 2 from the gauge. For 2 Ohms subtract 4. For example, a minimum gauge for a 50 foot 2 ohm run would be 10AWG.
- When using a very powerful amp with output of 1000 watts or more, it is best to use thicker speaker wire of at least 12AWG in all cases.

Loudspeaker Input Terminal Connection

When connecting the speaker wire to the XRT1.1K Loudspeaker Input Terminals, please follow these steps:

1. Rotate the end of the Input Terminal Post counterclockwise until an opening appears. Refer to *Figure 3*.
2. Insert the Loudspeaker hookup cable into the Input Terminal Post opening or the cable spade lug around the center post of the Input

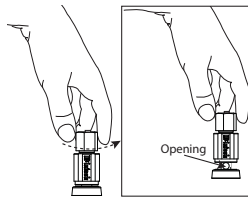

Figure 3— Opening Input Terminal

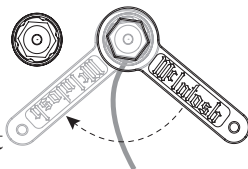

Figure 4— Tightening Input Post

Terminal. Refer to *Figure 3* again.

3. Rotate the end of the Input Terminal Post clockwise until it is finger tight.
4. Place the supplied McIntosh wrench over the end of the Input Terminal and rotate it one quarter of a turn (90°) to secure the Loudspeaker cable connection. **Do not over tighten.** (*Figure 4*)

The patented, gold-plated Solid Cinch™ speaker binding posts will also accept banana plug connections. Push the banana plug into the opening at the top of the binding post.

Single Amplifier Connection

The XRT1.1K has three pairs of Input Terminals labeled SUBWOOFER, LOW and MID/HIGH. If a single amplifier is to be used to power the XRT1.1K, connect the single amplifier to one pair of Input Terminals and the supplied Jumper Cables (*Figure 5*) can be used to connect the remaining two pairs of Input Terminals. Attach the Spade Terminals of the Jumper Cables as described above in Loudspeaker Input Terminal Connection. Use Jumpers to connect Negative Terminals to Negative Terminals and Positive to Positive. In the end, the pair of Input Terminals with the amplifier connected should be daisy chained to the remaining terminals that do not have an amplifier attached. Be careful to observe correct polarity. **Never connect an input pair with an amplifier attached to another pair with another amplifier attached.**

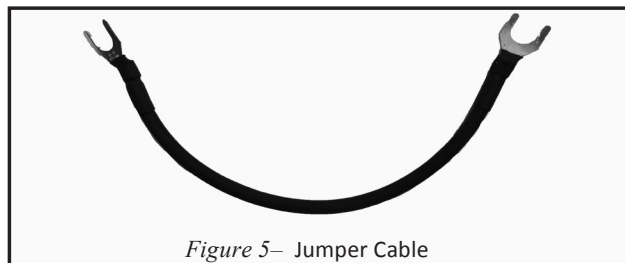

Figure 5— Jumper Cable

Multiple Amplifier Connections

The XRT1.1K Speaker can be powered by up to three separate power amplifiers. To use three power amplifiers, follow the instructions “Loudspeaker Input Terminal Connection” above for each pair of cables from each power amplifier to each of the three pairs of terminals on the XRT1.1K (MID/HIGH, LOW and SUBWOOFER). **Do not use jumper cables**, and always take care to observe proper polarity.

To power the XRT1.1K with two amplifiers, connect each power amp to a separate pair of terminals. Use a pair of jumper cables to connect the shared terminals. Typically, one amplifier would power the SUBWOOFER, and the MID/HIGH and LOW terminals would be powered by a separate power amplifier with jumpers connecting the pairs. It does not matter which pair of the jumpered terminals you choose to connect to the Power Amplifier.

Less Resistance

The XRT1.1K is an 8 Ohm speaker, and this is the recommended connection from an amplifier. Some people will use a 4 Ohm connection from an amplifier as a kind of equalization. For instance, using a 4 Ohm connection on the MID/HIGH will result in a 3db drop in that range. Bass can be lowered in the same manner for use in a boomy room. If this is something you wish to play around with, just remember to NEVER use a higher Ohm output of an amplifier such as 16 Ohm. This will result in heat generation beyond the amplifier’s design.

Making It Glow

To illuminate the McIntosh name plate, power needs to be connected to the XRT1.1K. Using a power control connection cable, connect the Power Control Out of a McIntosh component to the Power Control



In of the XRT1.1K. A cable can then be run from the Power Control Out of the XRT1.1K to the In of the other speaker. (Figure 6)

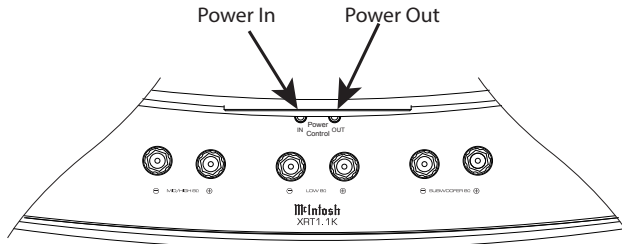

Figure 6– Power Control Connection

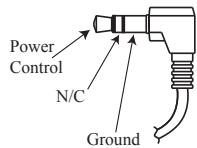

Figure 7– Power Control Jack

The Data and Power Control Cable is McIntosh part number 170-202. It is a six-foot shielded 3 conductor cable with 1/8 inch stereo mini phone plugs on each end. This cable will receive an On/Off signal to illuminate the McIntosh nameplate when other McIntosh components are turned on. (Figure 7)

Failure to connect the Power Control Cable will not affect the sound in any way, but the lighted nameplate will not glow.

Cleaning and Care

Wood is a natural living material that can be affected by environmental conditions. It would be best to keep the Loudspeakers away from heat sources or windows and avoid exposing them to

direct sunlight.

To clean the wood, use a soft microfiber cloth and a neutral detergent. Glass cleaner diluted in 50% water would work. Heavy duty detergents or waxes may stain the finish and are not recommended.

A soft brush can be used to remove dust. Take extreme care not to damage any of the Loudspeakers' delicate membranes.

Packing it Up

The below diagrams show the proper parts needed to safely rebox the XRT1.1K. To obtain replacement parts contact McIntosh Customer Service (see page 3). Make sure all packing material is in good condition to properly protect the XRT1.1K.

Part Numbers for Packing Material

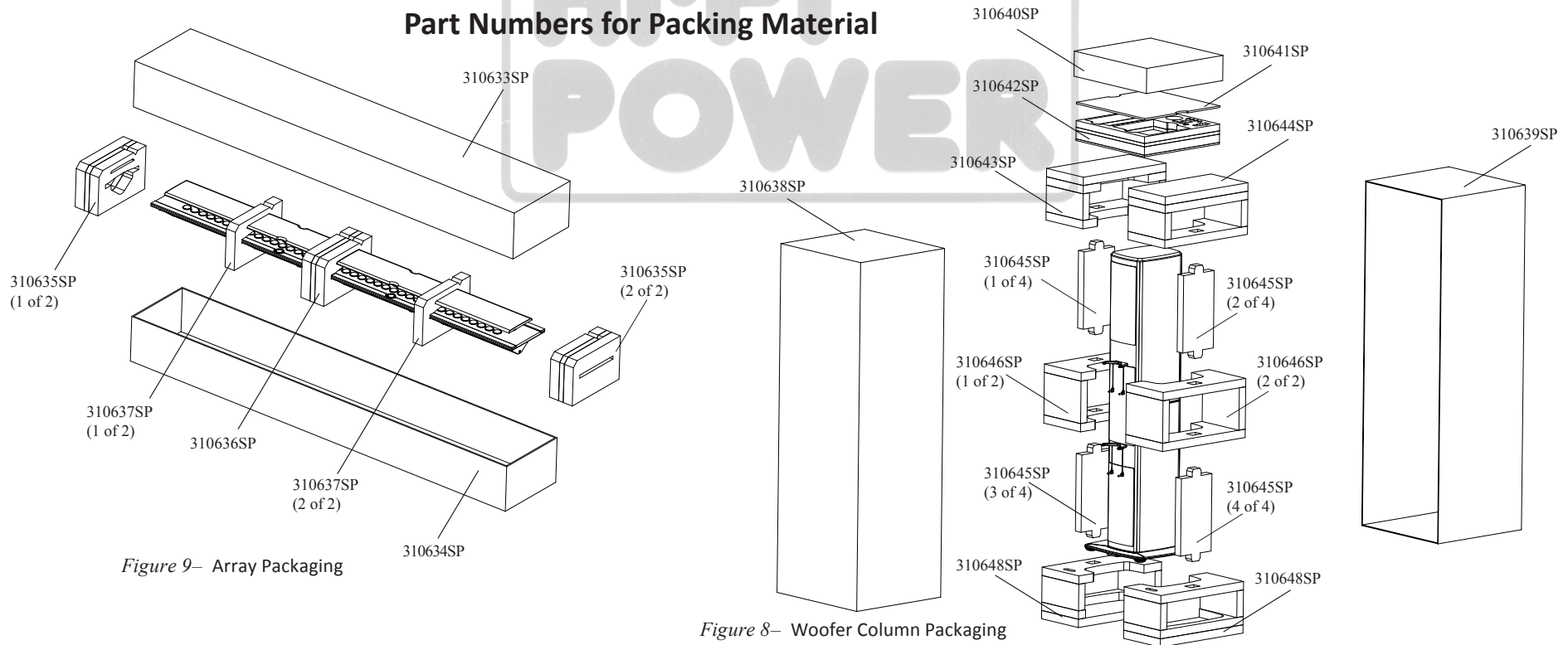

What's Inside

When creating a speaker that is a work of art as well as a triumph of science, choosing the right components is only half the battle; it may even be the easier half. Long-throw Nanocarbon Honeycomb Fiber Sandwich Cone woofers, renowned for their lightening quick yet flat response, are an easy choice. So is adding 64 more cutting-edge Loudspeakers for the mids and highs, and then meticulously designing every aspect down to the built-in heatsinks in the crossover's resistors to maintain consistent resistance at high power levels. Rare earth neodymium magnets are employed in all the drivers. Neodymium magnets are the strongest permanent magnets commercially available.

The art half of creating these speakers is the brilliant implementation of all these top-of-the-line elements. For instance, the Line Array technology used in arranging the drivers brings unparalleled performance with imaging and detail experienced over a large listening area well beyond the limited sweet spot of other high end Loudspeakers. The precise implementation of the finest materials is the crowning achievement of the XRT1.1K.

More About Line Array

If you want to know more about the XRT1.1K's use of Line Array Technology, this section is for you:

With traditional, non-line array Loudspeakers, the highs fall off at the square of the distance. If you measure the output of the tweeters and move backwards until the highs fall off 3dB, (this distance will vary somewhat with the room and speaker type) from that point back, the highs will drop an additional 3dB for every 2 meters farther away from the speakers. This means that the sound in the back

of a large room will have noticeably diminished highs with non-line array Loudspeakers. But, with the Line Array technology of the XRT1.1K, the highs fall off at the cube of the distance, so it is 3dB down every 6 meters from the first 3dB down point, giving a good mix of highs, mids and lows for about 36 meters back.

Another problem with traditional, non-line array speakers in a stereo pair is those speakers have a 30 degree on-axis response, with sound output and quality and imaging dropping off beyond that 30 degrees. With the speakers necessarily spread far apart, triangles of off-axis response are created between and to the sides of those speakers. With McIntosh Line Array speakers, the on-axis response is 130 degrees, leaving nearly the entire room on-axis for optimal sound and full stereo imaging.

Traditional, non-line array speakers need to be VERY loud right next to the speaker to be of sufficient volume in the back of the room. With the McIntosh Line Array speaker, even though the array is 130 degrees on-axis response, each individual driver is still 30 degrees on-axis; so, if you stand right next to the speaker, you are only on-axis to a few drivers. If you back a bit you are on-axis to some drivers, and farther away you are on-axis to all the drivers. As drivers are quieter when you are off-axis, a person right next to the Loudspeaker and one further away will hear about the same volume of music.

Another advantage of the Line Array Technology is that the large number of drivers in the Line Array mean they can handle vast amounts of power; in addition, the property of acoustic coupling (2 drivers next to each other pick up 3dB more output with no increase in power) makes the Line Array speaker very efficient.

The Crossover Network

The parts you cannot see are great too. The Crossover Network used in the XRT1.1K Loudspeaker System is designed to ensure an even frequency response over the entire audible range. The Crossover Network utilizes capacitors and inductors with high performance and high current capacity. The XRT1.1K uses low-loss inductors in the crossover network. The type of inductor used in each section of the crossover network has been chosen with special metallic cores for high linearity, even at high power levels. This prevents distortion of the music at any frequency. The resistors used in the crossovers have a built-in heatsink to maintain their resistance values while at the same time handling high power levels. The crossover network also employs self-resetting high current PTC type fuses to provide an extra measure of protection for the Loudspeaker Drivers.

Driver and Port Locations

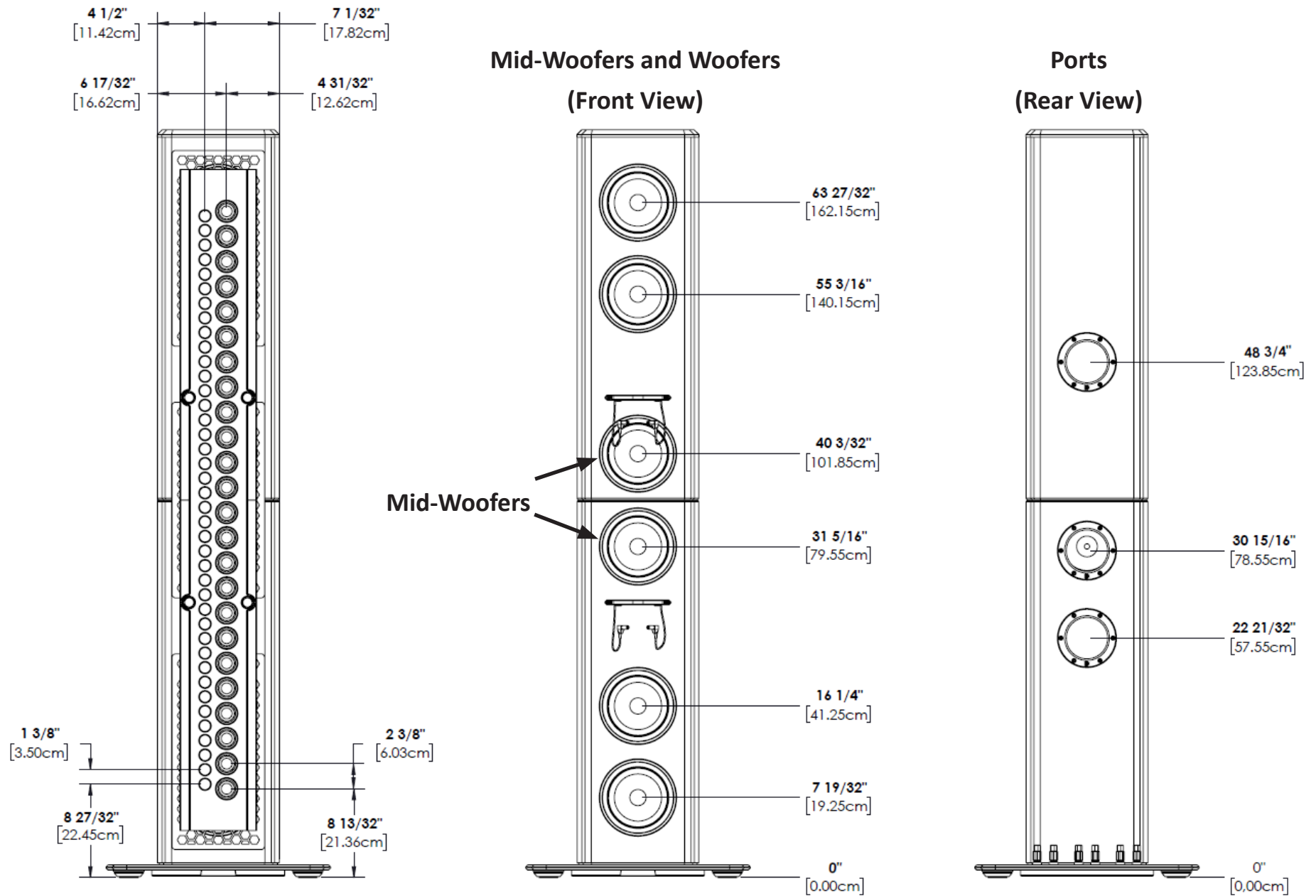

Figure 10– Driver and Port locations

Dimensions

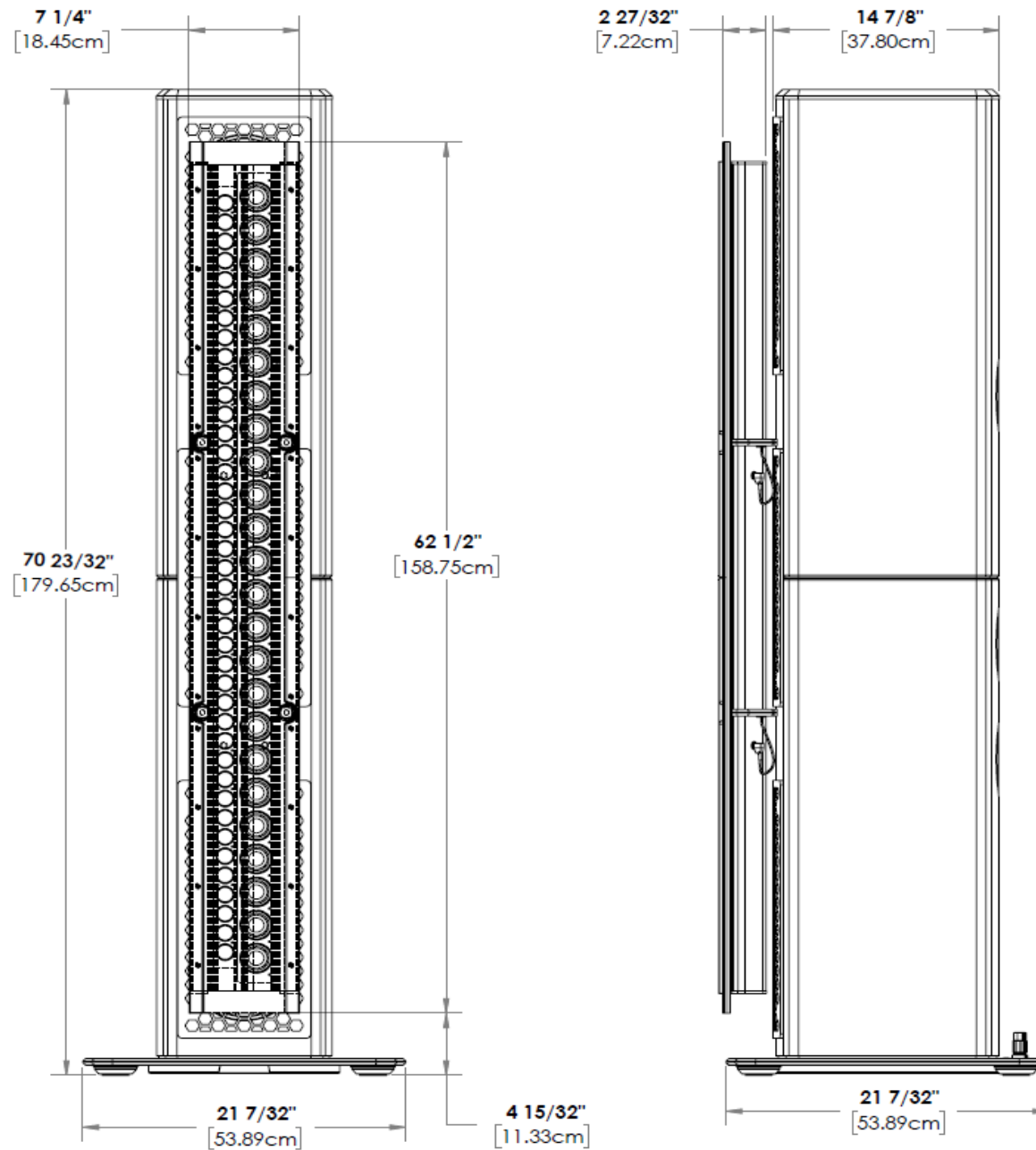

Figure 11– Dimensions



Specifications

Drivers

Four 6.5 inch long throw carbon fiber sandwich cone Woofers (Vented)

Two 6.5 inch” dome shaped carbon fiber sandwich diaphragm Mid-Woofers (Vented)

Twenty-Four 2.5 inch aluminum cone 1 inch voice coil Midrange (Sealed)

Forty (40) 3/4 inch aluminum dome Tweeters

Impedance

8 Ohms Nominal

Frequency Response

Anechoic Response: 16Hz – 45kHz

Sensitivity

89dB (2.83V/1m equivalent)

Crossover Frequencies

150Hz, 400Hz, 2kHz

Power Handling

1,200 Watts

McIntosh Logo Power Requirement

5VDC to 12VDC at 1mA

Operating Temperature

41-95°F

5-35°C

Operating Humidity

30-85%

Overall Dimensions

Height is 70-23/32 inches (179.65cm)

Width is 21-7/32 inches (53.89cm)

Depth is 21-7/32 inches (53.89cm)

Weight

180.8 pounds (82 kg)

318.5 pounds (144.5 kg) in shipping cartons

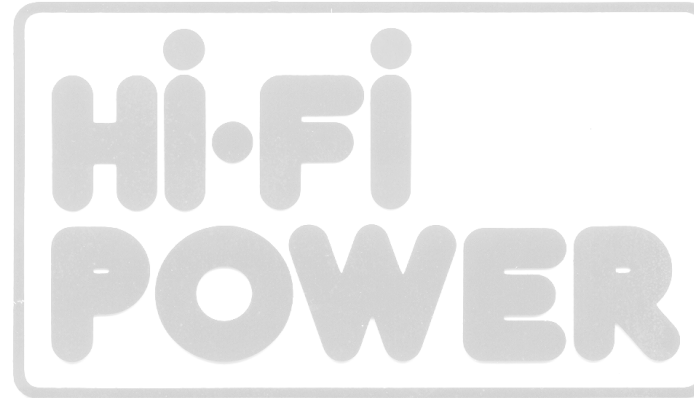

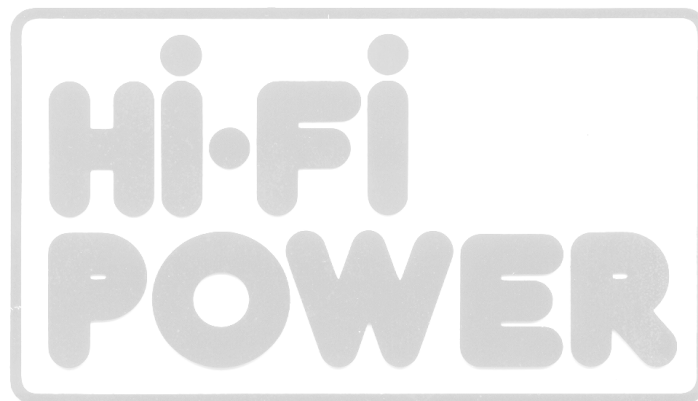



The continuous improvement of its products is the policy of McIntosh Laboratory, Inc. who reserves the right to improve design without notice.
Printed in the U.S.A.

McIntosh Part Number 04189200