



McIntosh Laboratory, Inc. 2 Chambers Street Binghamton, New York 13903-2699 Phone: 607-723-3512 www.mcintoshlabs.com

C22
Tube Preamplifier
Owner's Manual



HOME &
PROFESSIONAL
AUDIOVISUAL

• MAPNH 8 AΘHNA 10433 • THΛ. 210 3845676 - 210 3845272 FAX. 210 3809747 • e-mail: sales@hifipower.gr •



Important Safety Information is supplied in a separate document "Important Additional Operation Information Guide"

Thank You

With the McIntosh C22 Stereophonic Preamplifier, you have invested in a precision instrument that will provide you with many years of enjoyment. Please take a few moments to familiarize yourself with the features and instructions to get the maximum performance from your equipment.

If you need further technical assistance, please contact your Dealer who may be more familiar with your particular setup including other brands. You can also contact McIntosh with additional questions or in the unlikely event of needing service.

Please Take A Moment

The serial number, purchase date and McIntosh Dealer name are important to you for possible insurance claim or future service. The spaces below have been provided for you to record that information:

Serial Number: _____

Purchase Date: _____

Dealer Name: _____

Technical Assistance

If at any time you have questions about your McIntosh product, contact your McIntosh Dealer who is familiar with your McIntosh equipment and any other brands that may be part of your system. If you or your Dealer wish additional help concerning a suspected problem, you can receive technical assistance for all McIntosh products at:

McIntosh Laboratory, Inc.
2 Chambers Street
Binghamton, New York 13903
Phone: 607-723-3512
Fax: 607-724-0549

Customer Service

If it is determined that your McIntosh product is in need of repair, you can return it to your Dealer. You can also return it to the McIntosh Laboratory Service Department. For assistance on factory repair return procedure, contact the McIntosh Service Department at:

McIntosh Laboratory, Inc.
2 Chambers Street
Binghamton, New York 13903
Phone: 607-723-3515
Fax: 607-723-1917

Table of Contents

Safety Instructions	2
(Separate Sheet)	Important Additional
	Operation Information Guide
Thank You and Please Take a Moment.....	2
Technical Assistance and Customer Service	2
Table of Contents	2
General Information	3
Connector and Cable Information	3
Introduction.....	4
Performance Features	4
Dimensions	5
Installation	6
Rear Panel Connections.....	7
How to Connect the C22.....	8
Connection Diagrams (Separate Sheets)....	Mc1A and
	Mc1B
How to use the Remote Control.....	9-10
Front Panel Displays, Controls, Switches	
and Jack.....	11
How to Operate the C22	12-13
Specifications.....	14
Packing Instruction.....	15

Copyright 2019 © by McIntosh Laboratory, Inc.

General Information

1. The C22 uses Vacuum Tubes for amplifying the audio signal. The C22 is designed to have only qualified Service Personnel perform any part(s) replacement including all the vacuum tubes.
2. For additional connection information, refer to the owner's manual(s) for any component(s) connected to the C22 Stereophonic Preamplifier.
3. The Main AC Power going to the C22 and any other McIntosh Component(s) should not be applied until all the system components are connected together. Failure to do so could result in malfunctioning of some or all of the system's normal operations. When the C22 and other McIntosh Components are in their Standby Power Off Mode, the Microprocessor's Circuitry inside each component is active and communication is occurring between them.
4. Balanced and Unbalanced Inputs and Outputs can be mixed. For example, you may connect signal sources to Unbalanced Inputs and send signals from the Balanced Outputs. You can also use Balanced and Unbalanced Outputs simultaneously, connected to different Power Amplifiers.
5. The C22 Remote Control is capable of operating other components. For additional information go to www.mcintoshlabs.com.
6. The IR Input, with a 3.5mm stereo mini phone jack, is configured for non-McIntosh IR sensors such as a Xantech Model DL85K Kit. Use a Connection Block such as a Xantech Model ZC21 when two or more IR sensors need to be connected to the C22. The signal from a connected External IR Sensor will have priority over the signal from the Front Panel IR Sensor.

7. When discarding the unit, comply with local rules or regulations. Batteries should never be thrown away or incinerated but disposed of in accordance with the local regulations concerning battery disposal.
8. For additional information on the C22 and other McIntosh Products please visit the McIntosh Web Site at www.mcintoshlabs.com.

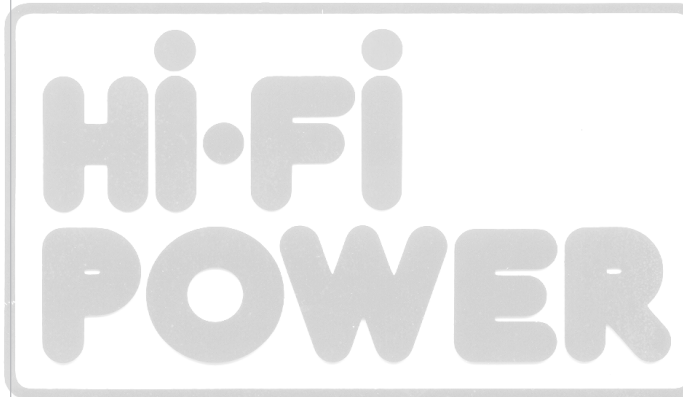

Connector and Cable Information

XLR Connectors

Below is the Pin configuration for the XLR Balanced Input and Output Connectors on the C22. Refer to the diagrams for connections:

- PIN 1: Shield/Ground
- PIN 2: + Signal
- PIN 3: - Signal

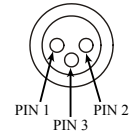

Power Control Connectors

The C22 Power Control Output Jacks send Power On/Off Signals when connected to McIntosh Components. An additional connection is for controlling the illumination of the Power Output Meters on McIntosh Power Amplifiers. Refer to page 8 for additional information. A 3.5mm stereo mini phone plug is used for connection to the Power Control Outputs.

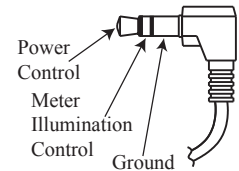

Data Port Connectors

The C22 Data Out Ports send Remote Control Signals to McIntosh Source Components. A 3.5mm stereo mini phone plug is used for connection.

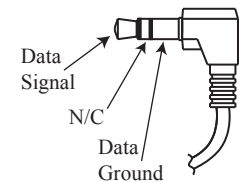

IR IN Port Connectors

The IR IN Port also uses a 3.5mm stereo mini phone plug and allows the connection of other brand IR Receivers to the C22.

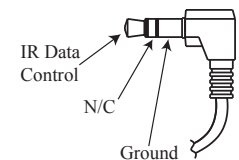

Introduction

The McIntosh C22 Stereophonic Preamplifier is one of the finest Tube Preamplifiers ever created. The versatile Preamplifier provides connections for various input sources and outputs to drive multiple Power Amplifiers. The C22 reproduction is sonically transparent and absolutely accurate. The McIntosh Sound is “The Sound of the Music Itself.”

Performance Features

• Electromagnetic Input Switching

Digital Logic integrated circuits drive Electromagnetic Switches on all Inputs and operating functions for reliable, noiseless, distortion free switching.

• Moving Coil and Moving Magnet Phono Inputs

The C22 contains two different precision Phono Preamplifier Circuits. One for low output Moving Coil Phono Cartridges with selectable resistance loading, the other is for Moving Magnet Cartridges with selectable capacitive loading. Both circuits use the latest designs to provide the lowest possible noise and distortion. The RIAA Equalization Circuitry utilizes close tolerance resistors and capacitors for an extremely flat frequency response.

• Balanced Inputs

The Balanced Inputs allow the connection of a source component using long cable lengths without a loss in sound quality.

• Low Distortion

Distortion levels of all types are less than 0.08%. Music is amplified with total transparency and accuracy.

• Variable Rate Volume and Balance Control

The C22 Preamplifier’s Volume and Balance Control Circuitry provides an ideal rate of change with control rotation.

• Tone Controls with Bypass

The C22 allows for bypassing the Bass and Treble Tone Circuitry.

• Output Switching

Front panel Output Push-buttons control two Switched Outputs that allow sending signals to two separate Power Amplifiers.

• HXD® for Headphones

The C22 Headphone Crossfeed Director Circuitry (HXD®) improves the sound localization for Headphone Listening. HXD® restores the directionality component of the spatial sound stage normally heard with Loudspeaker listening.

• Remote Control

The Remote Control provides basic control of the C22 operating functions and any McIntosh Source Components connected to it.

• Power Control Output

A Power Control connection for convenient Turn-On of McIntosh Power Amplifiers, Source Components and Accessories is included.

• Precision Parts

Only the finest precision 1% tolerance resistors are used throughout.

• Special Power Supply

Fully regulated Power Supplies and a special R-Core Power Transformer ensure stable noise free operation even though the power line varies.

• Solid State Front Panel Illumination

The Illumination of the Front Panel is accomplished by extra long life Light Emitting Diodes (LEDs).

• Glass Front Panel and Super Mirror Chassis Finish

The famous McIntosh Illuminated Glass Front Panel and the Lower Chassis are Stainless Steel with a Mirror Finish. The Upper Chassis and Top Cover have a glass window to view the amplifying vacuum tubes. This will ensure the pristine beauty of the C22 will be retained for many years to come.

Dimensions

The following dimensions can assist in determining the best location for your C22.

Front View of the C22

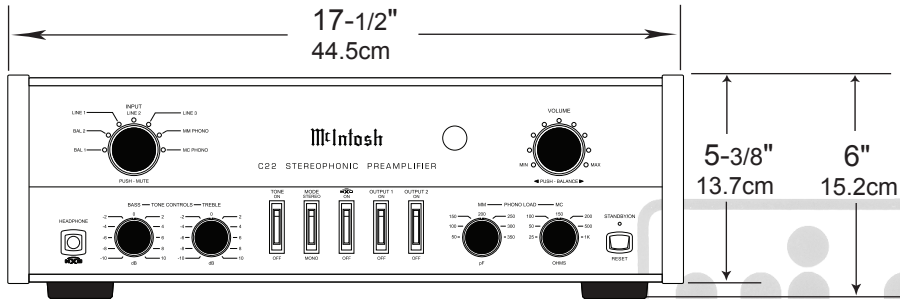

Side View of the C22

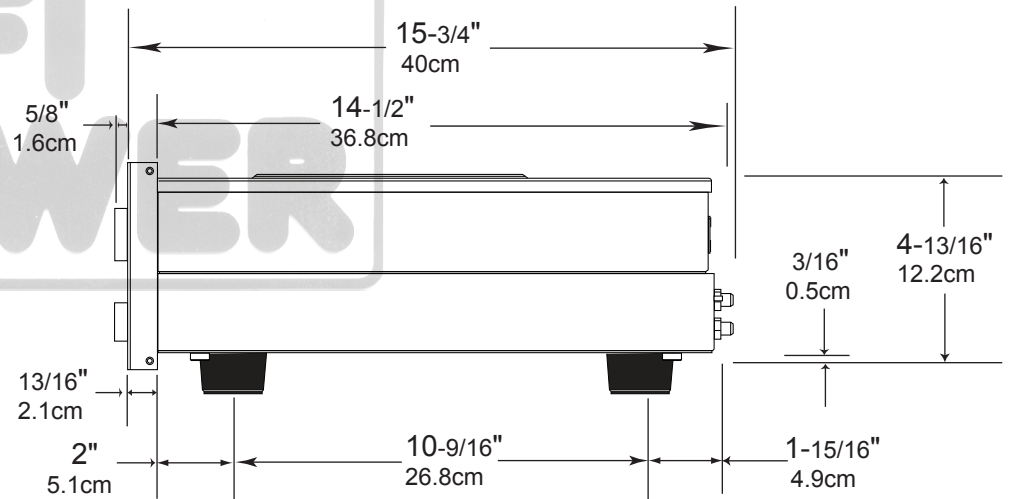

Rear View of the C22

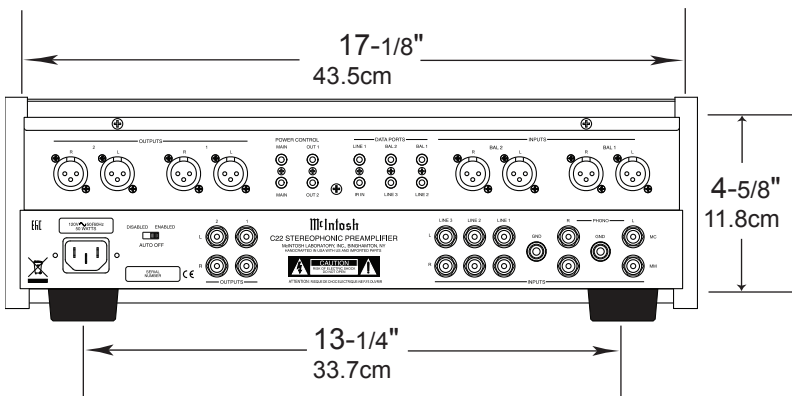

Installation

The C22 can be placed upright on a table or shelf, standing on its four feet. It also can be custom installed in a piece of furniture or cabinet of your choice. The four feet may be removed from the bottom of the C22 when it is custom installed as outlined below. The four feet together with the mounting screws should be retained for possible future use if the C22 is removed from the custom installation and used free standing. The required panel cutout, ventilation cutout and unit dimensions are shown.

Always provide adequate ventilation for your C22. Cool operation ensures the longest possible operating life for any electronic instrument. Do not install the C22 directly above a heat generating component such as a high powered amplifier. If all the components are installed in a single cabinet, a quiet running ventilation fan can be a definite asset in maintaining all the system components at the coolest possible operating temperature.

A custom cabinet installation should provide the following minimum spacing dimensions for cool operation.

Allow at least 6 inches (15.24cm) above the top, 2 inches (5.08cm) below the bottom and 1 inch (2.54cm) on each side of the Tube Preamplifier, so that airflow is not obstructed. Allow 19-1/2 inches (49.53cm) depth behind the front panel. Allow 1-1/8 inch (2.9cm) in front of the mounting panel for knob clearance. Be sure to cut out a ventilation hole in the mounting shelf according to the dimensions in the drawing.

**C22 Front Panel
Custom Cabinet Cutout**

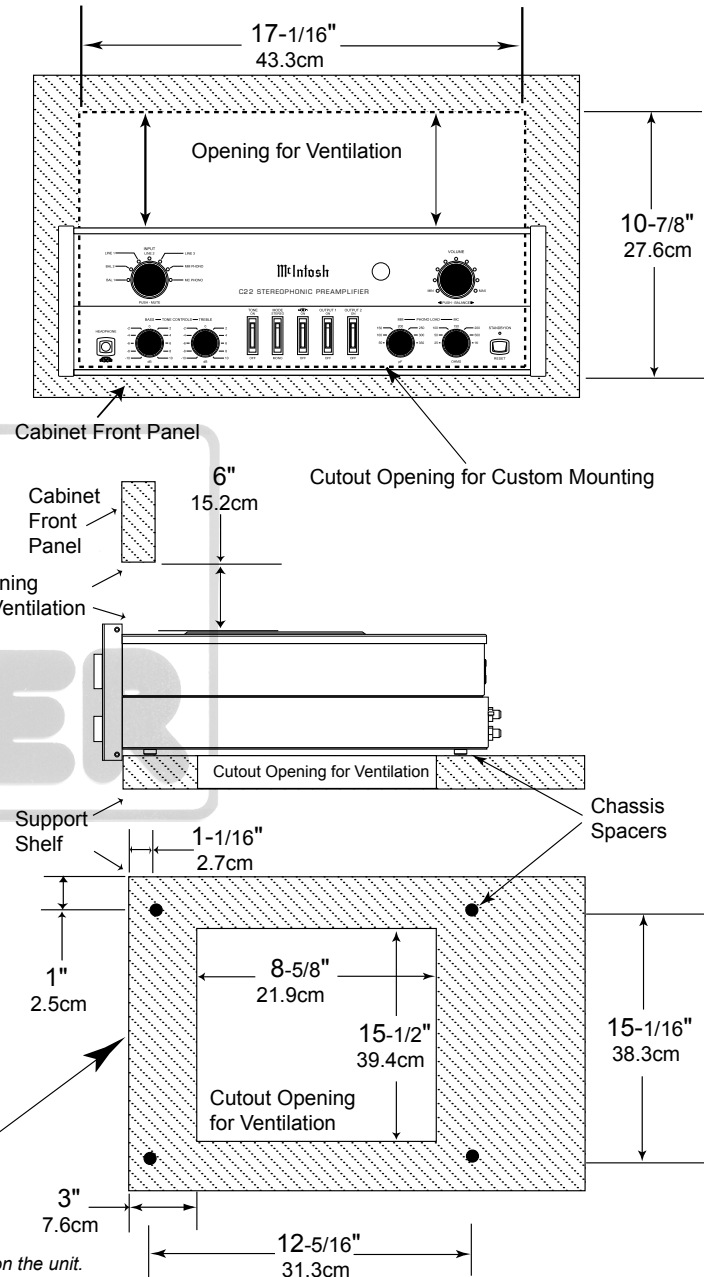

Note: Center the cutout horizontally on the unit.
For purposes of clarity, the above illustration is not drawn to scale.

OUTPUTS 1 and 2 send signals to Power Amplifiers and are switched On/Off with the Front Panel OUTPUT 1 and 2 Switches

OUTPUT 1 and OUTPUT 2 send Turn-On Signals to McIntosh components and are controlled by the C22 Front Panel OUTPUT 1 and OUTPUT 2 Switches

INPUTS BALANCED 1 and 2 accept high level program source signals

POWER CONTROL MAIN Outputs send Turn-On Signals to McIntosh Components when the C22 is switched On

DATA PORTS send signals to McIntosh Source Components to allow control with the C22 Remote Control

AUTO OFF Switch activates the C22 Power Save Circuitry

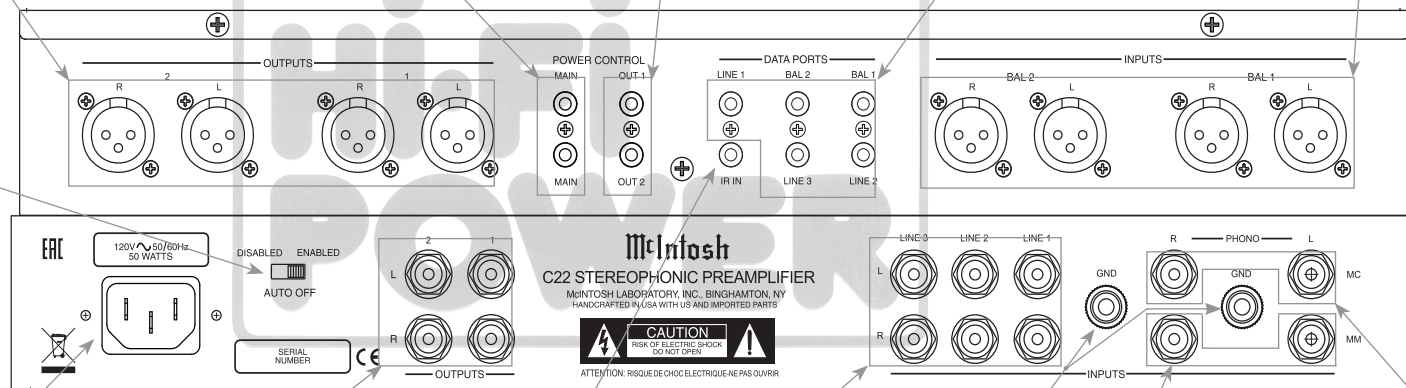

OUTPUTS unbalanced 1 and 2 send Audio Signals to a Power Amplifier and are controlled by the C22 Front Panel OUTPUT 1 and 2 Switches

INPUTS (unbalanced) accept high level program source Audio Signals

PHONO MM accepts signals from a Moving Magnet phono cartridge

Connect the C22 power cord to a live AC outlet. Refer to information on the back panel of your C22 to determine the correct voltage for your unit

IR INput for signals from a compatible IR Room Sensor

GND terminals accept a ground wire from a turntable

PHONO MC accepts signals from a Moving Coil phono cartridge

How to Connect the C22

The C22 has the ability to automatically switch power On/Off to McIntosh Source Components via the Power Control connections. The Data Port Connections allow for the remote operation of basic functions using the C22 Remote Control.

The connection instructions below, together with the C22 Input and Output Connection Diagrams located on the separate folded sheet “Mc1A/1B”, are an example of a typical audio system. Your system may vary from this, however the actual components would be connected in a similar manner. For additional information refer to “Connector and Cable Information” on page 3.

Power Control Connections:

1. Connect a Control Cable from the C22 POWER CONTROL MAIN (upper) Jack to the Turntable Power Control In Jack.
2. Connect a Control Cable from the Turntable Power Control Out Jack to the Music Server PWR CTRL (Power Control) In Jack.
3. Connect a Control Cable from the Music Server PWR CTRL (Power Control) Out Jack to the SACD/CD Player Power Control Remote In Jack.
4. Connect a Control Cable from the SACD/CD Player Power Control Remote Out Jack to the AM/FM Tuner Control In Jack.
5. Connect a Control Cable from the C22 POWER CONTROL OUT 1 Jack to the Stereo Power Amplifier (Main Room) Power Control In Jack.
6. Optionally, connect a Control Cable from the Power Amplifier (Main Room) Power Control Out Jack to the Left Channel Loudspeaker Power Control In Jack.
7. Optionally, connect a Control Cable from the Left Channel Loudspeaker Power Control Out Jack to the Right Channel Loudspeaker Power Control In Jack.

8. Connect a Control Cable from the C22 POWER CONTROL OUT 2 Jack to the Stereo Power Amplifier (Secondary Room) Power Control In Jack.
9. Optionally, connect a Control Cable from the Power Amplifier (Secondary Room) Power Control Out Jack to the Left Channel Loudspeaker Power Control In Jack.
10. Optionally, connect a Control Cable from the Left Channel Loudspeaker Power Control Out Jack to the Right Channel Loudspeaker Power Control In Jack.
11. Connect any additional McIntosh Components in a similar manner, as outlined in steps 1 thru 4.

Data Control Connections:

12. Connect a Control Cable from the C22 LINE 1 DATA PORTS Jack to the AM/FM Tuner Data In Jack.
13. Connect a Control Cable from the C22 BALANCE 1 DATA PORT Jack to the SACD/CD Player Data In Jack.
14. Connect a Control Cable from the C22 LINE 2 DATA PORT Jack to the Music Streamer Data In Jack.
15. Connect any additional McIntosh Components in a similar manner, as outlined in steps 12 thru 14.

Audio Connections:

16. Connect an Audio Cable from the C22 LINE 1 INPUT Jacks to the AM/FM Tuner UNBALANCED Output Connectors.
17. Connect Balanced Cables from the C22 BALANCED 1 INPUT Jacks to the SACD/CD Player Balanced Output Connectors.

Note: Unbalanced Audio Cables may be used to connect to a C22 Unbalanced Input instead of the Balanced Input.

18. Connect an Audio Cable from the C22 LINE 2 INPUT Jacks to the Music Streamer Unbalanced Output Jacks.
19. Connect the Audio Cables coming from the Turntable to the C22 MC PHONO L and R INPUT Jacks.

Note: If the Turntable has a Moving Magnet Cartridge, connect the audio cables to the C22 MM PHONO L and R INPUT Jacks instead of the MC Input.

20. Connect any additional McIntosh Components in a similar manner, as outlined in steps 16 thru 19.
21. Connect Balanced Cables from the C22 OUTPUTS 1 L and R Connectors Jacks to the Power Amplifier (Main Room) Balanced Input Jacks.

Note: Unbalanced Audio Cables may be used to connect to C22 Unbalanced Output 1 Jacks instead of the Balanced Output Connectors.

22. Optionally, connect Balanced Audio Cables from the C22 OUTPUT 2 L and R Connectors to the McIntosh Power Amplifier (Secondary Room) Balanced Input Jacks.

Note: Unbalanced Audio Cables may be used to connect to C22 Unbalanced Output 2 Jacks instead of the Balanced Output Connectors.

Ground Connections:

23. Connect the Ground Cable coming from the Turntable to the C22 GND Binding Post.

AC Power Cords Connections:

24. Connect the C22 AC Power Cord to a live AC outlet as illustrated.

LEDs illuminate during the time a remote command is sent and when programming the remote control

Select the DEVICE to issue a remote control command to

Selects AM Tuner Operating Functions and Track Selection on certain McIntosh CD Players

TRIM selects the Power Control Meter Illumination Setting for connected McIntosh Power Amplifiers

Scrolls through the available INPUTS

Mutes the audio

Selects transport functions of STOP, PLAY/PAUSE, RECORD, BACK for the previous-selection, FAST-REVERSE, FAST-FORWARD and NEXT for the next selection

Selects Previous Tuner Station PRESET

Tuner scans Down the dial to SEEK the next Station

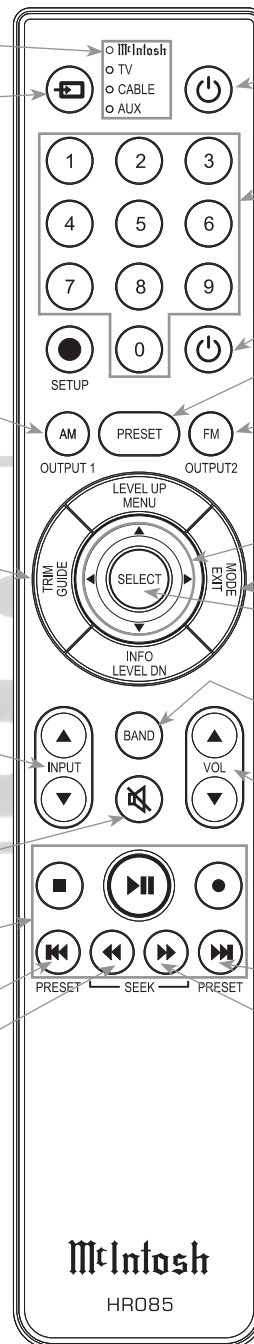

Press to Power the C22 On

Use to select tuner presets, direct access an AM/FM Station Frequency, disc tracks or any numbered operation

Press to Power the C22 Off

Direct access to stored Tuner PRESETS when used with the numeric Push-buttons (0 thru 9)

Selects FM Tuner Operating Functions and Track Selection on certain McIntosh CD Players

Use ▲ and ▼ to tune Up or Down the AM/FM Dial, use ► and ◀ for the next or previous HD Radio Program (where applicable)

Use to enable or disable Tube Lights

Use to SELECT/Enter the indicated choice on certain McIntosh Models

Press to change Broadcast BANDs on a connected Tuner. Select certain functions on a variety of McIntosh Models

Adjusts the VOLume level up or down

Selects Next Tuner Station PRESET

Tuner scans Up the dial to SEEK the next Station

Note: Push-buttons whose function is not identified above are for use with other McIntosh Products.

How to use the Remote Control

The supplied C22 Remote Control (HR085) is capable of directly controlling the functions of contemporary McIntosh Source Components connected to the C22 via the Data Ports.

- Notes:
1. If at any time the C22 seems unresponsive to the HR085 Remote Control Commands, press the  DEVICE Push-button to select **McIntosh** first.
 2. For additional information on using the HR085 Remote Control with the McIntosh Model, please refer to the "How to Operate" starting on page 12.

Mute Selection

Press the MUTE  Push-button on the Remote Control to Mute the Audio in the PREAMP OUTPUTS (Loudspeakers) and Headphones. The C22 Front Panel Volume Control LED at the 12 O'Clock Position will flash On and Off while the Audio is muted.

Pressing the Mute Push-button a second time or adjusting the Volume Control will un-mute the C22. The LED Illumination of the Volume Control will return to its previous setting.

Trim Selection

The C22 Default Setting for Meter Illumination of connected McIntosh Power Amplifiers, is ON. If it is desirable to have McIntosh Power Amplifiers' Meter Illumination switched OFF, press the TRIM (Guide) push-button on the Remote Control after the C22 is passed its warm-up mode.

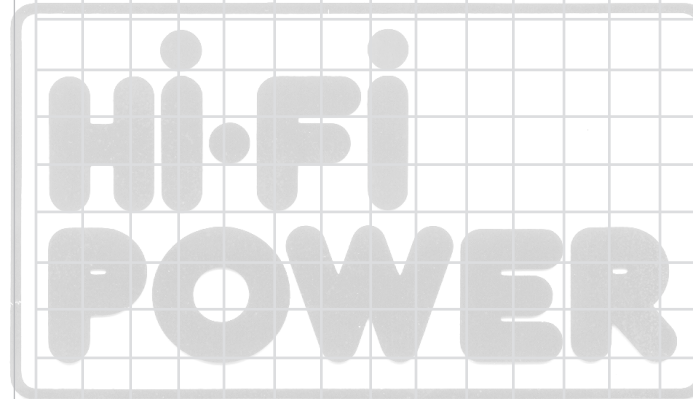

INPUT SELECTOR Control selects the desired audio signals for listening and recording

IR Sensor receives commands from a Remote Control

STANDBY/ON Push-button with indicator switches the C22 ON or OFF (Standby) and resets the microprocessors

OUTPUTS 1 and 2 switches allow the C22 to switch Power Control and Audio to two separate Power Amplifiers

VOLUME Control adjusts the listening level for both channels and BALANCE Control allows the adjustment of the relative volume balance between channels

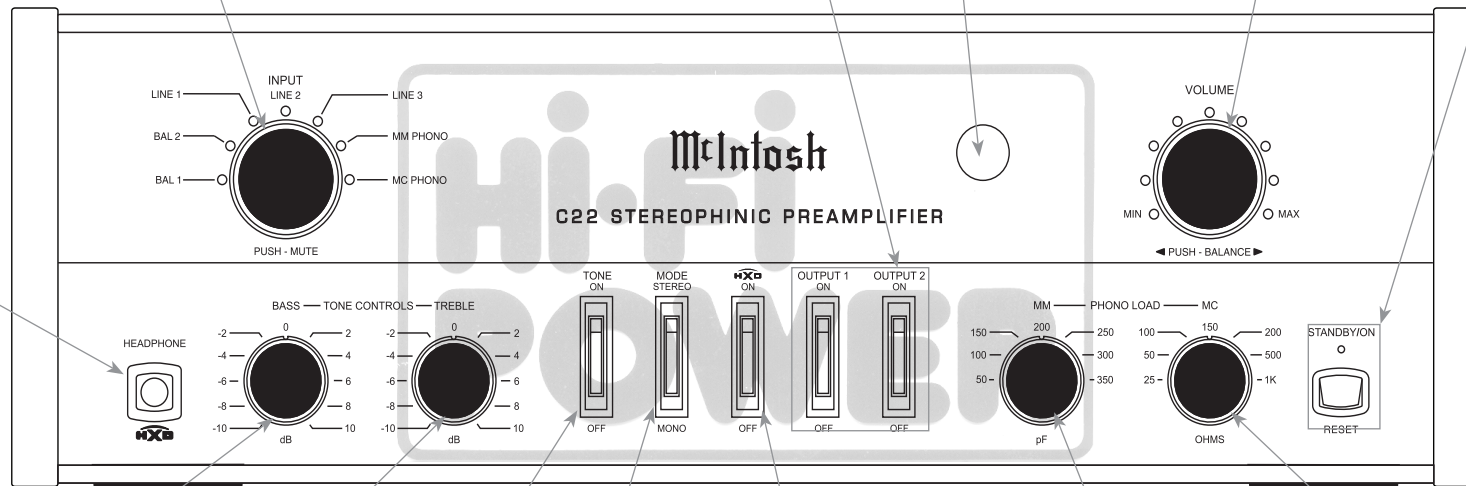

Connection for low impedance dynamic headphones, for private listening

BASS Control provides 10dB boost or cut with a center flat position

TONE Controls are activated or deactivated for the current audio signal

HXD activates the acoustical depth and spatiality of music normally heard with loudspeakers, to your headphones

PHONO LOAD MC OHMS provides seven different resistive loads for a Moving Coil Phono Cartridge



TREBLE Control provides 10dB boost or cut with a center flat position

MODE allows for listening to various channel combinations from STEREO to MONO

PHONO LOAD MM pF provides seven different capacitive loads for a Moving Magnet Phono Cartridge



How to Operate

Power On and Off



The Red LED above the STANDBY/ON Push-button lights to indicate the C22 is in Standby mode. Press the STANDBY/ON Push-button on the Front Panel or the  (Green) Push-button on the Remote Control. The C22 will go through a TUBE WARMUP (approximately 16 seconds) with the Tubes glowing an amber color. The LEDs around the INPUT and VOLUME CONTROLS also become Rotational Active during TUBE WARMUP. The Tubes will then glow green in color and the Input Source and Volume Setting return to the previous settings. Switch the C22 OFF by pressing the STANDBY/ON Push-button or the  (Red) Push-button on the Remote Control.

Note: For an explanation of the Remote Control Push-button functions, refer to pages 9 and 10.

Source Selection

Select the desired source using the INPUT SELECTOR Control on the Front Panel or press the INPUT  or  on the Remote Control. The illuminated LEDs around the control indicate the selected source.

Volume Control

Rotate the Front Panel VOLUME Control or use the VOLume  (Up) or  (Down) Push-buttons on the Remote Control for the desired listening level. The LEDs surrounding the VOLUME Control indicate the current volume setting between the MINimum and MAXimum setting of LEDs.

Mute Control

Press the INPUT/MUTE Control on the Front Panel to Mute the Audio in the PREAMP OUTPUTS (Loudspeakers) and Headphones. The C22 Front Panel Volume Control LED at the 12 O'Clock Posi-

tion will flash On and Off while the Audio is muted. Pressing the Mute Control a second time or adjusting the Volume Control will un-mute the C22. The LED Illumination of the Volume Control will return to its previous setting.

Balance Control

Adjust the Balance by pressing the VOLUME/BALANCE Control. The Default Setting is equal amplification for both channels, with illumination of the LED at the center (12 o'clock) position of the Control. Rotate the Control clockwise to increase the Right Channel Volume (LEDs on the right side of the BALANCE Control will illuminate) or Rotate the Control counterclockwise to increase the Left Channel Volume (LEDs on the left side of the BALANCE Control will illuminate). About Four Seconds after the VOLUME/BALANCE Control is no longer being rotated to adjust the Balance, the Control will return to being an adjustable Volume Control for both channels. To check the current Balance Setting, press the VOLUME/BALANCE Control and the LEDs will indicate the current BALANCE Setting.

Mode Selector

The Front Panel MODE SELECTOR Control allows the Left and Right Input Signals from the currently selected source to be combined to outputs sent to the Loudspeakers and Headphones.

Tone Switch

When the TONE Switch on the Front Panel is placed in the ON position, the BASS and TREBLE Controls become active. The OFF position of the TONE Switch deactivates the BASS and TREBLE Controls and the Tone Circuitry is totally bypassed for a flat response.

Bass Control

Rotate the BASS clockwise to emphasize the low frequency content of the music. Likewise, rotate the BASS counterclockwise to de-emphasize the low frequency content of the music.

Treble Control

Rotate the TREBLE clockwise from the center (12 o'clock) position to emphasize the high frequency content of the music. Likewise, rotate the TREBLE counterclockwise from the center position to de-emphasize the high frequency content of the music.

Output 1 and 2

To switch Off the audio signal going to the Power Amplifiers connected to the C22 Preamplifier Outputs, place the OUTPUT 1 and/or the OUTPUT 2 Rocker Switch in the OFF Position on the Front Panel. When there is a Power Control Connection between the C22 Power Control OUT 1 or OUT 2 and a Power Amplifier(s), the Power Amplifier(s) will be switched Off.

Phono Load Adjustments

There are Phono Load Adjustments for both types of Phono Cartridges, Moving Coil (MC) and Moving Magnet (MM). The resistive load for the MC Input is selectable from 25 ohms to 1,000 ohms. The capacitive load for the MM Input is selectable from 50 picofarads to 350 picofarads.

Select the Phono Load setting using the Front Panel MC or MM Control for the cartridge type connected to the C22. Choose the value closest to the recommended load value specified by the Phono Cartridge Manufacturer.

How to Operate, con't

Headphones Jack

Connect a pair of dynamic headphones with a 1/4 inch (6.3mm) stereo phone type plug to the Headphones Jack for private listening.

HXD Mode

When Headphones are connected to the Front Panel Headphone Jack, place the HXD® switch to the ON position to activate the HXD® Circuitry. To deactivate HXD® place the switch in the OFF position.

Note: HXD® improves the sound localization for Headphone Listening. HXD® restores the directionality component of the spatial sound stage normally heard with Loudspeaker listening.

Tube Lights

The MODE button on the Remote Control can be used to toggle the Tube Lights on and off. Refer to page 9 for the Remote Control diagram.

Auto Off Switch

The C22 incorporates an Auto Off Feature, which automatically places the Preamplifier into the Power Saving Standby/Off Mode. This occurs approximately 30 minutes after there has been an absence of user activity (includes changes to any of the Operation Functions such as source selection, volume adjustment, etc) or absence of an audio signal. If it is desirable to disable the Auto Off Feature, place the Rear Panel AUTO OFF Switch in the DISABLE position.

Reset of Microprocessors

In the unlikely event the controls of the C22 stop functioning, the microprocessors can be reset by placing the Front Panel STANDBY/ON Switch in the RESET

position by holding it in for fifteen seconds and then releasing the switch.

Factory Reset

To return the C22 to its original factory settings, press and hold the INPUT and VOLUME KNOBS for 5 seconds. The lights will turn off. Release the knobs.



Specifications
Frequency Response

+0, -0.5dB from 20Hz to 20,000Hz

+0, -3dB from 15Hz to 100,000Hz

Total Harmonic Distortion

0.08% from 20Hz to 20,000Hz

Rated Output (Output 1 and 2)

2.5V Unbalanced, 5V Balanced

Maximum Voltage Output

8V RMS Unbalanced, 16V RMS Balanced

Sensitivity (for rated output)

High Level, 450mV Unbalanced, 900mV Balanced

Phono MM, 4.5mV

Phono MC, 0.45mV

Signal To Noise Ratio (A-Weighted)

High Level - 100dB (Below rated output)

MM Phono - 75dB (Below 5mV input)

MC Phono - 75dB (Below 0.5mV input)

Input Impedance

High Level - 22K ohms Unbalanced

44k ohms Balanced

Phono MM, 50pF, 100pF, 150pF, 200pF, 250pF, 300pF
or 350pF; 47K ohms

Phono MC, 25, 50, 100, 150, 200, 500 or 1,000 ohms;
100pF

Maximum Input Signal

High Level, 5V Unbalanced, 10V Balanced

Phono MM, 50mV

Phono MC, 5mV

Tone Controls

Bass Control \pm 10dB @20Hz

Treble Control \pm 10dB @10,000Hz

Voltage Gain

High Level to Output 1 and 2: 15dB

Phono MM to Output 1 and 2: 40dB

Phono MC to Output 1 and 2: 60dB

Output Impedance

100 ohms Unbalanced

200 ohms Balanced

Headphone Load Impedance

16 ohms to 250 ohms

Power Control Output

12VDC, 25mA

Tube Compliment

6 Tubes, Five - 12AX7A and One - 12AT7

(viewed thru the Top Cover Window)

Power Requirements

Field AC Voltage conversion of the C22 is not possible. The C22 is factory configured for one of the following AC Voltages:

100V \sim 50/60Hz at 50 watts

110V \sim 50/60Hz at 50 watts

120V \sim 50/60Hz at 50 watts

127V \sim 50/60Hz at 50 watts

220V \sim 50/60Hz at 50 watts

230V \sim 50/60Hz at 50 watts

240V \sim 50/60Hz at 50 watts

Standby, less than 0.5 watts

Note: Refer to the rear panel of the C22 for the correct voltage.

Overall Dimensions

Width is 17-1/2 inches (44.45cm)

Height is 6 inches (15.24cm) including feet

Depth is 18 inches (45.72cm) including the Front

Panel, Knobs and Cables

Weight

25 pounds (11.3 kg) net, 41.4 pounds (18.8 kg) in shipping carton

Shipping Carton Dimensions

Width is 26-1/2 inches (67.3cm)

Depth is 24-1/4 inches (61.6cm)

Height is 11-3/4 inches (29.9cm)

Packing Instructions

In the event it is necessary to repack the equipment for shipment, the equipment must be packed exactly as shown below. It is very important that the four plastic feet are attached to the bottom of the equipment. This will ensure the proper equipment location on the bottom pad. Failure to do this will result in shipping damage.

Use the original shipping carton and interior parts only if they are all in good serviceable condition. If a shipping carton or any of the interior part(s) are needed, please call or write Customer Service Department of McIntosh Laboratory. Refer to page 2. Please see the Part List for the correct part numbers.

Quantity	Part Number	Description
1	033838	Shipping carton only
2	033837	End cap
1	033836	Inside carton only
1	034414	Top pad
1	034576	Bottom pad
4	017937	Plastic foot
4	400159	#10-32 x 3/4" screw
4	404080	#10 Flat washer

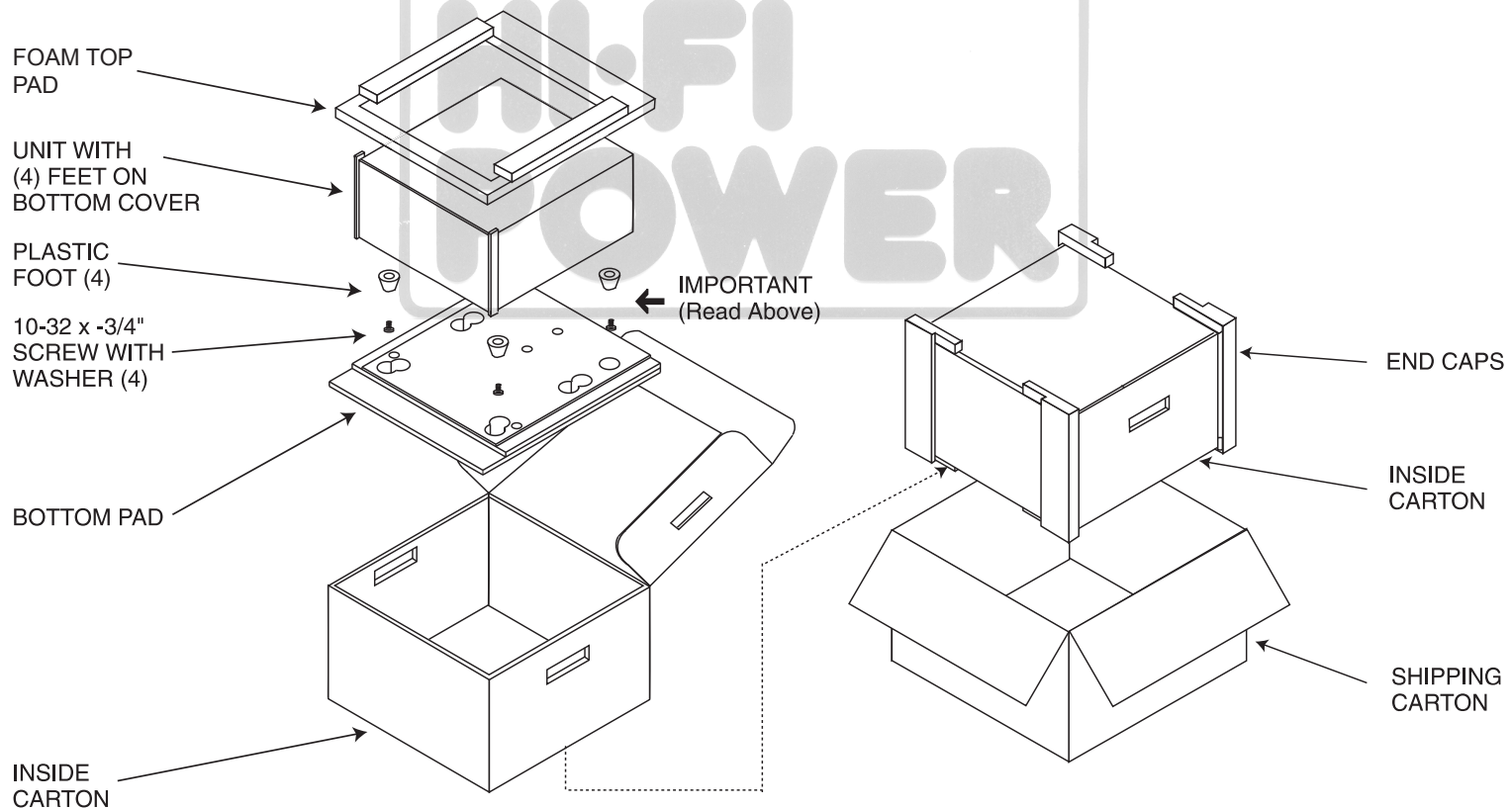



McIntosh Laboratory, Inc.
2 Chambers Street
Binghamton, NY 13903
www.mcintoshlabs.com

The continuous improvement of its products is the policy of McIntosh Laboratory Incorporated who reserve the right to improve design without notice.
Printed in the U.S.A.

McIntosh Part No. 24110000



HOME &
PROFESSIONAL
AUDIOVISUAL

• MAPNH 8 AΘHNA 10433 • THA. 210 3845676 - 210 3845272 FAX. 210 3809747 • e-mail: sales@hifipower.gr •